

# VAL-MS 320/3+1/FM-UD - Type 2 surge arrester



2856689

<https://www.phoenixcontact.com/gb/products/2856689>

Please be informed that the data shown in this PDF document is generated from our online catalog. Please find the complete data in the user documentation. Our general terms of use for downloads are valid.



Surge voltage arrester consisting of base element with remote indicator contact and ground connectors, for mounting on NS 35/7.5, nominal voltage: 320 V AC, 3 + 1 circuit

## Your advantages

- Quality proven millions of times over in the widest range of applications
- Rapid installation with bridges, thanks to industry-standard overall width of 1 HP
- Easy testing and insulation measurement, thanks to pluggable protection modules
- Wide range of applications due to various nominal voltages
- High degree of modularity provides individual solutions for every application

## Commercial data

Item number	2856689
Packing unit	1 pc
Minimum order quantity	1 pc
Sales key	CL1321
Product key	CL1321
Catalog page	Page 60 (C-4-2019)
GTIN	4017918877057
Weight per piece (including packing)	408 g
Weight per piece (excluding packing)	393.915 g
Customs tariff number	85363030
Country of origin	DE

# VAL-MS 320/3+1/FM-UD - Type 2 surge arrester



2856689

<https://www.phoenixcontact.com/gb/products/2856689>

## Technical data

### Product properties

Product type	Surge arrester
Product family	VALVETRAB MS
IEC test classification	II T2
EN type	T2
IEC power supply system	TN-S TT
Type	DIN rail module, two-section, divisible
Number of positions	4
Surge protection fault message	Optical, remote indicator contact

### Data management status

Article revision	21
------------------	----

### Insulation characteristics

Overvoltage category	III
Pollution degree	2

### Electrical properties

Nominal frequency $f_N$	50 Hz (60 Hz)
-------------------------	---------------

### Indicator/remote signaling

Connection name	Remote fault indicator contact
Switching function	Changeover contact
Operating voltage	5 V AC ... 250 V AC 30 V DC
Operating current	5 mA AC ... 750 mA AC 1 A DC

### Connection data

Connection method	Screw connection
Screw thread	M5
Tightening torque	3 Nm (1.5 mm <sup>2</sup> ... 16 mm <sup>2</sup> ) 4.5 Nm (25 mm <sup>2</sup> ... 35 mm <sup>2</sup> )
Stripping length	16 mm
Conductor cross section flexible	1.5 mm <sup>2</sup> ... 25 mm <sup>2</sup>
Conductor cross section rigid	1.5 mm <sup>2</sup> ... 35 mm <sup>2</sup>
Conductor cross section AWG	15 ... 2
Connection method	Fork-type cable lug
Conductor cross section flexible	1.5 mm <sup>2</sup> ... 16 mm <sup>2</sup>

### Remote fault indicator contact

# VAL-MS 320/3+1/FM-UD - Type 2 surge arrester



2856689

<https://www.phoenixcontact.com/gb/products/2856689>

Connection method	Plug-in/screw connection via COMBICON
Screw thread	M2
Tightening torque	0.25 Nm
Stripping length	7 mm
Conductor cross section flexible	0.14 mm <sup>2</sup> ... 1.5 mm <sup>2</sup>
Conductor cross section rigid	0.14 mm <sup>2</sup> ... 1.5 mm <sup>2</sup>
Conductor cross section AWG	28 ... 16

## Dimensions

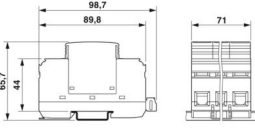
Dimensional drawing	
Width	71 mm
Height	98.7 mm
Depth	65.7 mm (incl. DIN rail 7.5 mm)
Horizontal pitch	4 Div.

## Material specifications

Color	black (RAL 9005)
Flammability rating according to UL 94	V-0
CTI value of material	600
Insulating material	PA 6.6/PBT
Material group	I
Housing material	PA 6.6 PBT

## Protective circuit

Mode of protection	L-N
	L-PE
	N-PE
Direction of action	3L-N & N-PE
Nominal voltage $U_N$	240/415 V AC (TN-S)
	240/415 V AC (TT)
Nominal frequency $f_N$	50 Hz (60 Hz)
Maximum continuous operating voltage $U_C$ (L-N)	335 V AC
Maximum continuous operating voltage $U_C$ (L-PE)	335 V AC
Maximum continuous operating voltage $U_C$ (N-PE)	260 V AC
Rated load current $I_L$	80 A
Residual current $I_{PE}$	$\leq 5 \mu A$
Standby power consumption $P_C$	$\leq 450.00$ mVA
Nominal discharge current $I_n$ (8/20) $\mu s$	20 kA
Maximum discharge current $I_{max}$ (8/20) $\mu s$	40 kA

# VAL-MS 320/3+1/FM-UD - Type 2 surge arrester



2856689

<https://www.phoenixcontact.com/gb/products/2856689>

Follow current interrupt rating $I_{fi}$ (N-PE)	100 A
Short-circuit current rating $I_{SCCR}$	25 kA
Voltage protection level $U_p$ (L-N)	$\leq 1.6$ kV
Voltage protection level $U_p$ (L-PE)	$\leq 1.9$ kV
Voltage protection level $U_p$ (N-PE)	$\leq 1.5$ kV
Residual voltage $U_{res}$ (L-N)	$\leq 1.6$ kV (at $I_n$ )
	$\leq 1.5$ kV (at 10 kA)
	$\leq 1.3$ kV (at 5 kA)
	$\leq 1.1$ kV (at 3 kA)
Residual voltage $U_{res}$ (L-PE)	$\leq 1.9$ kV (at $I_n$ )
	$\leq 1.5$ kV (at 10 kA)
	$\leq 1.3$ kV (at 5 kA)
	$\leq 1.2$ kV (at 3 kA)
Residual voltage $U_{res}$ (N-PE)	$\leq 0.4$ kV (at $I_n$ )
	$\leq 0.25$ kV (at 10 kA)
	$\leq 0.15$ kV (at 5 kA)
	$\leq 0.1$ kV (at 3 kA)
TOV behavior at $U_T$ (L-N)	415 V AC (5 s / withstand mode)
	440 V AC (120 min / safe failure mode)
TOV behavior at $U_T$ (N-PE)	1200 V AC (200 ms / withstand mode)
Response time $t_A$ (L-N)	$\leq 25$ ns
Response time $t_A$ (L-PE)	$\leq 100$ ns
Response time $t_A$ (N-PE)	$\leq 100$ ns
Max. backup fuse with V-type through wiring	80 A (gG)
Max. backup fuse with branch wiring	125 A (gG)

## Environmental and real-life conditions

### Ambient conditions

Degree of protection	IP20 (only when all terminal points are used)
Ambient temperature (operation)	-40 °C ... 80 °C
Ambient temperature (storage/transport)	-40 °C ... 80 °C
Altitude	$\leq 2000$ m (amsl)
Permissible humidity (operation)	5 % ... 95 %
Shock (operation)	25g (Half-sine / 11 ms / 3x $\pm X$ , $\pm Y$ , $\pm Z$ )
Vibration (operation)	5g (10 ... 500 Hz / 2.5 h / X, Y, Z)

## Approvals

### UL specifications

Maximum continuous operating voltage MCOV (L-L)	640 V AC
Maximum continuous operating voltage MCOV (L-N)	320 V AC
Maximum continuous operating voltage MCOV (L-G)	320 V AC
Maximum continuous operating voltage MCOV (N-G)	260 V AC
Nominal discharge current $I_n$ (L-L)	20 kA

# VAL-MS 320/3+1/FM-UD - Type 2 surge arrester



2856689

<https://www.phoenixcontact.com/gb/products/2856689>

Nominal discharge current $I_n$ (L-N)	20 kA
Nominal discharge current $I_n$ (L-G)	20 kA
Nominal discharge current $I_n$ (N-G)	20 kA
Mode of protection	L-L
	L-N
	L-G
	N-G
Nominal voltage	240/415 V AC
Power distribution system	Wye
Nominal frequency	50/60 Hz
Measured limiting voltage MLV (L-L)	2900 V
Measured limiting voltage MLV (L-N)	2030 V
Measured limiting voltage MLV (L-G)	2720 V
Measured limiting voltage MLV (N-G)	1370 V
SPD Type	4CA

## UL indicator/remote signaling

Operating voltage	125 V AC
AC operating current	1 A AC

## UL connection data

Tightening torque	30 lb <sub>F</sub> -in.
Conductor cross section AWG	14 ... 2

## Standards and regulations

Standards/specifications	IEC 61643-11
Note	2011
Standards/specifications	EN 61643-11
Note	2012

## Mounting

Mounting type	DIN rail: 35 mm
---------------	-----------------

# VAL-MS 320/3+1/FM-UD - Type 2 surge arrester

2856689

<https://www.phoenixcontact.com/gb/products/2856689>

## Drawings

### Application drawing

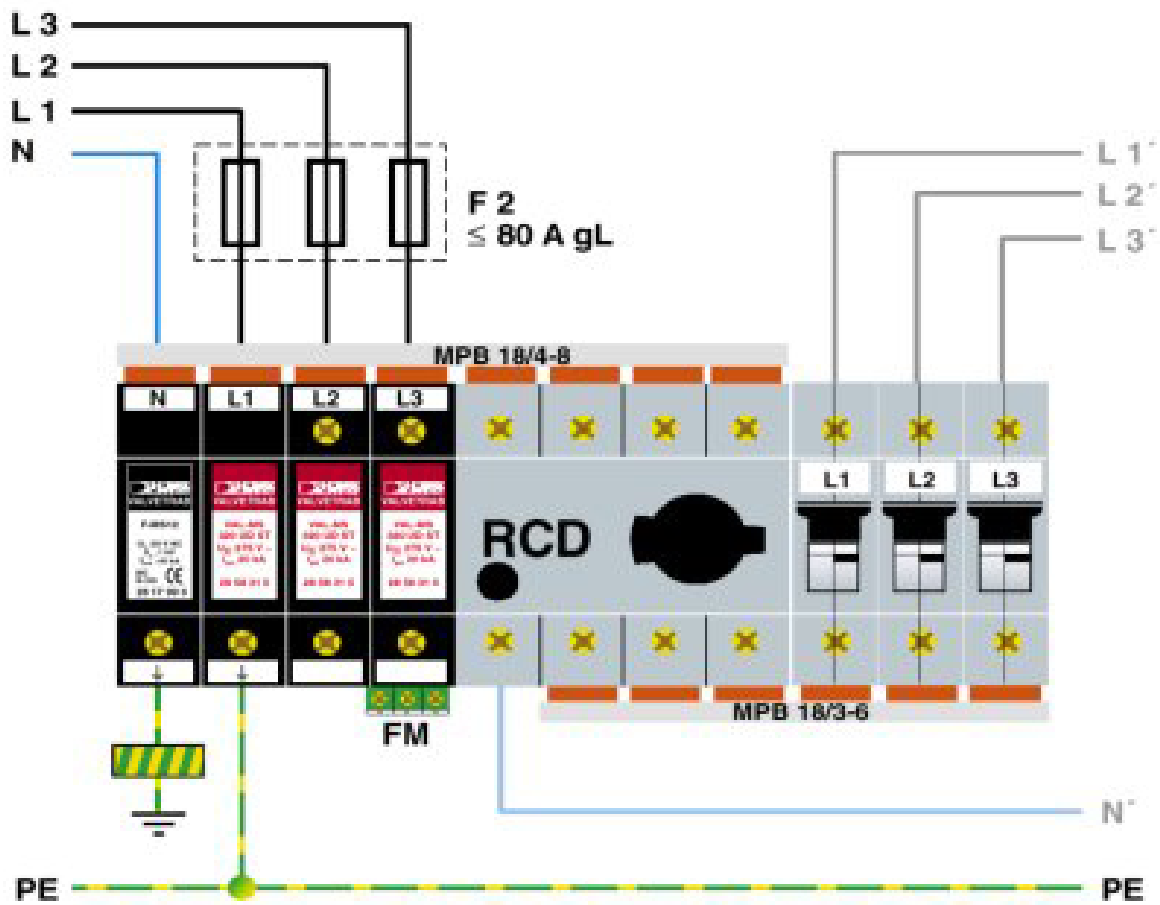

# VAL-MS 320/3+1/FM-UD - Type 2 surge arrester

2856689

<https://www.phoenixcontact.com/gb/products/2856689>

Application drawing

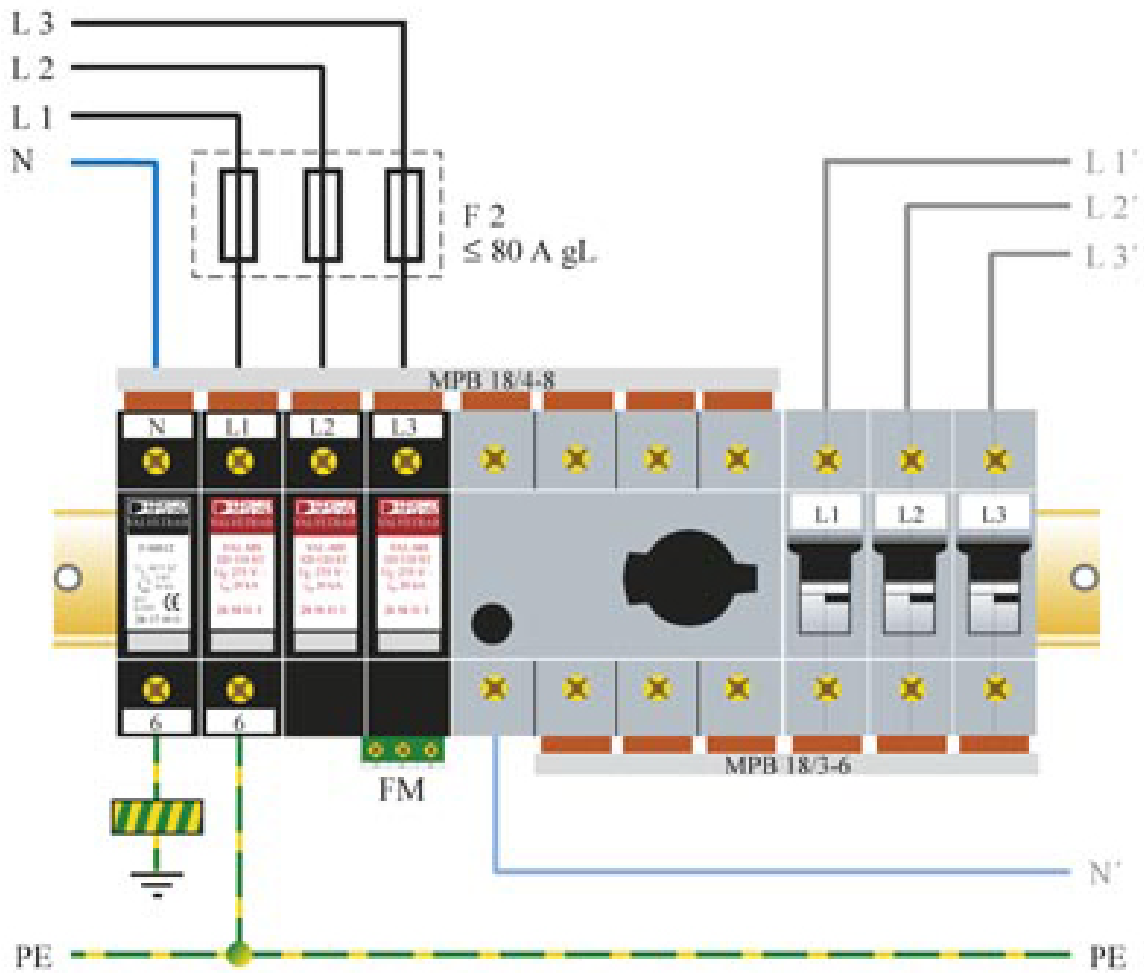

# VAL-MS 320/3+1/FM-UD - Type 2 surge arrester



2856689

<https://www.phoenixcontact.com/gb/products/2856689>

Circuit diagram

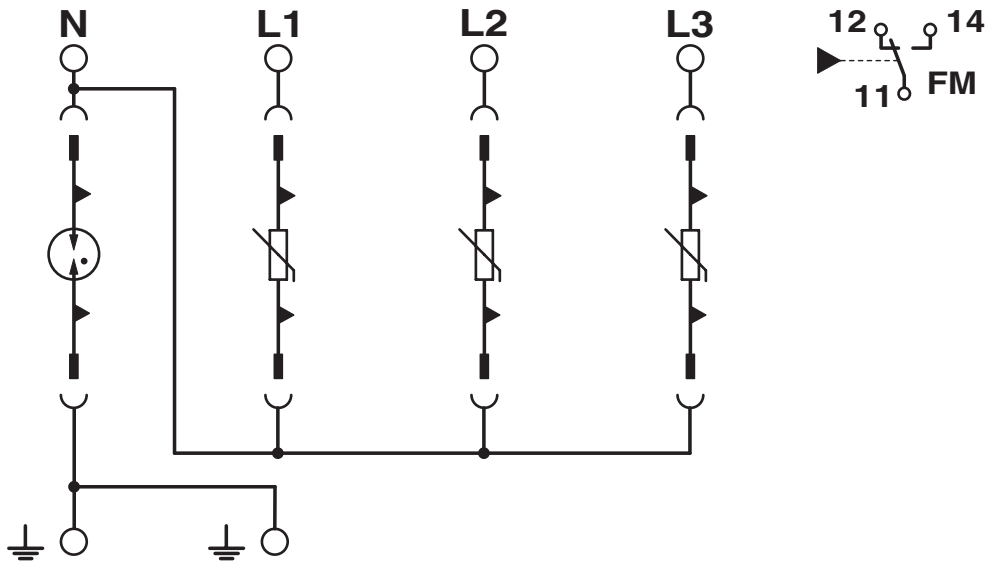

Dimensional drawing

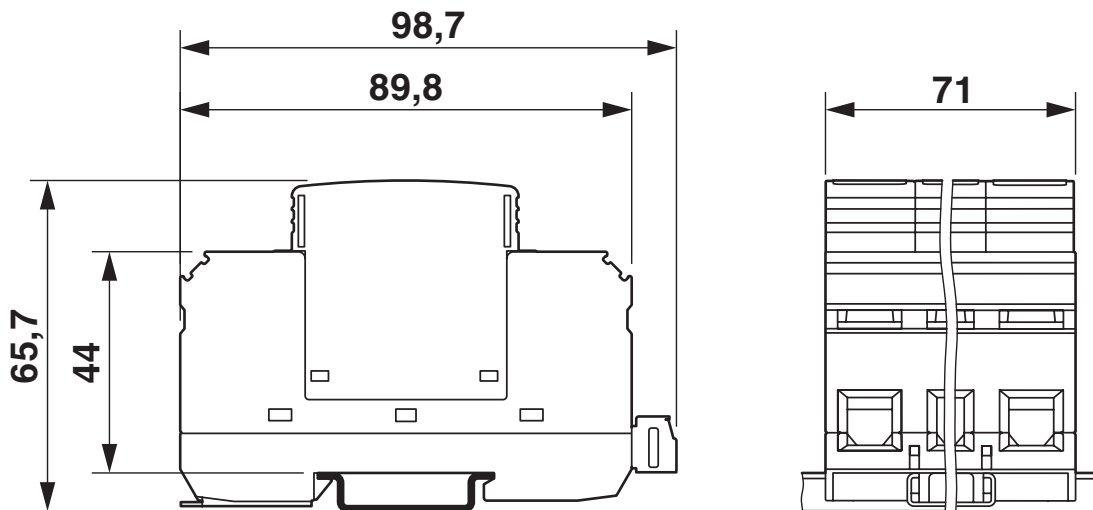

# VAL-MS 320/3+1/FM-UD - Type 2 surge arrester



2856689

<https://www.phoenixcontact.com/gb/products/2856689>

## Approvals

To download certificates, visit the product detail page: <https://www.phoenixcontact.com/gb/products/2856689>



**cUL Recognized**

Approval ID: FILE E 330181



**UL Recognized**

Approval ID: FILE E 330181



**IECEE CB Scheme**

Approval ID: AT 2905/M1



**EAC**

Approval ID: EAC-Zulassung

**CCA**

Approval ID: NTR-AT 1947-A



**KEMA-KEUR**

Approval ID: 71-113273 REV.1



**EAC**

Approval ID: RU C-DE.\*09.B.00169



**CSA**

Approval ID: 13631



**ÖVE**

Approval ID: 18583-001-17

**UAE-RoHS**

Approval ID: 22-09-51250

**cULus Recognized**

# VAL-MS 320/3+1/FM-UD - Type 2 surge arrester



2856689

<https://www.phoenixcontact.com/gb/products/2856689>

## Classifications

### ECLASS

ECLASS-11.0	27130805
ECLASS-13.0	27171202

### ETIM

ETIM 9.0	EC000941
----------	----------

### UNSPSC

UNSPSC 21.0	39121600
-------------	----------

# VAL-MS 320/3+1/FM-UD - Type 2 surge arrester



2856689

<https://www.phoenixcontact.com/gb/products/2856689>

## Environmental product compliance

### EU RoHS

Fulfills EU RoHS substance requirements	Yes, No exemptions
---	--------------------

### China RoHS

Environment friendly use period (EFUP)	EFUP-E
	No hazardous substances above the limits

### EU REACH SVHC

REACH candidate substance (CAS No.)	No substance above 0.1 wt%
-------------------------------------	----------------------------

Phoenix Contact 2024 © - all rights reserved  
<https://www.phoenixcontact.com>

PHOENIX CONTACT Ltd  
Halesfield 13, Telford  
Shropshire, TF7 4PG  
01952 681700  
[info@phoenixcontact.co.uk](mailto:info@phoenixcontact.co.uk)