

# **NETYS PR**

## 1000-1500 VA RACK 1U

- 安装及操作手册 (CN)
- Installations- und bedienungsanleitung (DE)
- Manual de instalación y uso (ES)
- Manuel d'installation et d'utilisation (FR)
- Installation and operating manual (GB)
- Manuale di installazione e uso (IT)
- Прирачник за инсталација и употреба (MK)
- Installatie- en bedieningshandleiding (NL)
- Dokumentacja Techniczno-Ruchowa (PL)
- Manual de instalação e funcionamento (PT)
- Manual de instalare și utilizare (RO)
- Руководство по установке и эксплуатации (RU)
- Navodila za priključitev in uporabo (SI)
- Kurulum ve kullanım kılavuzu (TR)

# WARRANTY CERTIFICATE AND CONDITIONS

This SOCOMEC UPS appliance is guaranteed against manufacturing and material defects for a period of 12 months from the date of purchase (local warranty conditions are applicable in addition to the general conditions). This warranty certificate should NOT be e-mailed, but kept by the customer along with proof of purchase, for use in the event of a claim being made for repairs or replacement under warranty.

The warranty period commences on the date the new product was purchased by the end user at an authorised showroom (reference details are shown on the receipt).

Return-to-base warranty is provided: components and labour for repairs supplied free of charge, any products to be replaced must be returned to SOCOMEC UPS or authorised service centres, at the customer's own risk and expense.

The warranty is recognized within national territory. If the UPS is exported out of national territory, the warranty shall be limited to the cover of the parts used to repair the fault.

To claim service under the warranty please observe the following:

- The product must be returned in the original packing. Any damage caused during shipping in packaging other than the original will not be covered by the warranty;
- The product must be accompanied by proof of purchase such as an invoice or receipt indicating the date of purchase and product ID information (model, serial number). The sender must also attach the reference number issued to authorise the return of the product, together with a detailed description of the defect. If any of this information is missing the warranty will be invalid. The authorisation number is issued by service centres over the telephone on receiving information on the malfunction in question;
- If it is not possible to provide proof of purchase the serial number and date of manufacture will be used to calculate the probable expiry date of the warranty; this could result in a reduction of the original warranty period.

The warranty on the product does not cover damage caused by carelessness (improper use: wrong input power, explosions, excessive humidity, temperature, poor ventilation, etc.), tampering or any unauthorised repair work.

During the warranty period, SOCOMEC UPS reserves the right to decide whether the product should be repaired, or whether to replace defective parts with new parts, or used parts that are equivalent to new parts in terms of functionality and performance.

In the case of batteries, warranty is valid only if the battery has been recharged regularly in accordance with the manufacturer's instructions. On purchasing the product it is advisable to check that the next recharge date indicated on the packaging has not expired.

## Battery

- Batteries are treated as consumable parts and warranty only covers manufacturing defects.
- Batteries must be stored in compliance with Supplier recommendations.
- Warranty is valid only if the battery has been recharged regularly in accordance with the manufacturer's instructions. On purchasing the product it is advisable to check that the next recharge date indicated on the packaging has not expired.

## Optionals

A 12-month return-to-base warranty is provided on optionals.

## Software products

Software products are guaranteed for 90 days. The software is guaranteed to work as indicated in the manual accompanying the product. Hardware media or accessories (e.g. diskettes, cables, etc.) used with appliances are guaranteed free of material or manufacturing defects under normal conditions of use for a period of 12 months from the date of purchase.

SOCOMECE UPS will not be responsible for damages (including loss of income, interruption of business activity, loss of information or other financial losses, of any nature) arising from the use of the product.

These conditions are subject to Italian law. Disputes shall come under the jurisdiction of Court of Vicenza.

SOCOMECE UPS retains the full and exclusive ownership rights over this document. Only a personal right to utilize the document for the application indicated by SOCOMEC UPS is granted to the recipient of such document. All reproduction, modification, dissemination of this document whether in part or whole and by any manner are expressly prohibited except upon Socomec's express prior written consent.

This document is not a specification. SOCOMEC UPS reserves the right to make any changes to data without prior notice.

# SUMMARY

1. SAFETY STANDARDS . . . . .	4
1.1. IMPORTANT . . . . .	4
1.2. DESCRIPTION OF THE SYMBOLS USED ON THE LABELS APPLIED TO THE UNIT . . . . .	4
2. GENERAL DESCRIPTION . . . . .	5
2.1. INTRODUCTION . . . . .	5
3. INSTALLATION . . . . .	6
3.1. MOUNTING THE UPS IN A 19" RACK . . . . .	6
4. FRONT VIEW . . . . .	9
5. REAR VIEW . . . . .	10
6. INTERNAL BATTERY CONNECTION . . . . .	11
7. MODES OF OPERATION . . . . .	12
7.1. TURNING THE UPS ON . . . . .	12
7.2. TURNING THE UPS OFF . . . . .	12
7.3. STANDBY MODE . . . . .	12
7.4. INITIATING THE SELF-TEST . . . . .	12
8. ADDITIONAL UPS FEATURES . . . . .	13
8.1. VOLTAGE CONFIGURATION . . . . .	13
8.2. NETWORK TRANSIENT PROTECTOR . . . . .	13
9. COMMUNICATION . . . . .	14
9.1. COMMUNICATION SOLUTIONS . . . . .	14
9.2. RS232 INTERFACE . . . . .	14
9.3. USB INTERFACE . . . . .	14
9.4. NET VISION OPTIONAL CARD FOR SLOT . . . . .	14
9.5. USE OF WARNING RELAY INTERFACE . . . . .	14
10. TROUBLESHOOTING . . . . .	15
10.1. SILENCING AN AUDIBLE ALARM . . . . .	15
10.2. TROUBLESHOOTING . . . . .	15
11. TECHNICAL SPECIFICATIONS . . . . .	17

# 1. SAFETY STANDARDS

## 1.1. IMPORTANT

This manual must be kept next to the UPS, so that the operator may consult it at any time for clarification on the correct use of the UPS. Read the manual carefully before connecting the unit to the mains power supply and to the devices to be powered. Before switching on the UPS (Uninterruptible Power Supply), the operator must be fully aware of the functions and positions of all the controls and of the technical and functional characteristics of the system, in order to avoid any risk to persons and to the equipment.

- Before starting, the unit must have an equipotential connection as established by the safety standards in force. The earth cable of the UPS must be connected to an efficient earth point.
- If the unit is not earthed, all devices connected to the UPS will not have an equipotential connection. In this case the manufacturer declines all responsibility for damage or accidents caused by non-observance of the aforementioned standards.
- This is a pluggable type A equipment with battery already installed by the supplier, it's operator installable and may be operated by layman.
- In case of power failure (UPS in back up mode), do not disconnect the input cable from the mains so as to ensure earth connection to the powered loads.
- All subsequent maintenance operations must be carried out solely and exclusively by authorized personnel. Inside the system high electric voltages are generated which may endanger maintenance personnel who are not sufficiently prepared and trained for such tasks.
- If at any time a hazard condition is created during use, disconnect the mains power supply (if possible through the control panel upstream of the unit) and shutdown the UPS completely following the appropriate procedure.
- When assembling and replacing the battery, the UPS should always be switched off and disconnected from the mains power supply. Do not dispose of batteries in a fire, the battery may explode.



### CAUTION

A battery can present a risk of electric shock and high short circuit current.

The following precaution should be observed when working on batteries: remove watches, rings or other metal objects and use tools with insulated handles.

- The batteries constitute an internal power source for the UPS and mean that the system output may be powered even when the UPS is not connected to the mains power supply.
- Do not force, break or try to open the batteries. They are sealed and do not require any maintenance. They contain substances that are toxic to health and that pollute the atmosphere. Do not switch the UPS on if any leakage of liquid or white powder residue is noted.
- Replace batteries with the same number and type of batteries as originally installed in the equipment.
- Replace the fuses ONLY with other fuses of the same type.
- As the mains cable of the UPS is considered a disconnecting device, the mains socket to which the UPS is connected and/or the rear of the UPS must be accessible and easy to disconnect.
- Avoid contact of the UPS unit with water or liquids in general. Do not introduce foreign bodies.
- If the unit needs to be scrapped, it must be handed over solely and exclusively to specialist disposal companies. These companies are obliged to break up and dispose of the various components in accordance with the national legal provisions in force.
- During the installation of this UPS, it should be assured that the sum of the leakage current of UPS and connected loads does not exceed 3.5 mA.
- Netys UPS is intended for commercial and industrial use; it is not recommended for use in medical applications that are essential to the survival of the patient.
- Use the UPS in accordance with the technical specifications given in the User Manual.

## 1.2. DESCRIPTION OF THE SYMBOLS USED ON THE LABELS APPLIED TO THE UNIT

All the precautions and the warnings on the labels and plates on the inside and outside of the equipment should be respected.



**DANGER! HIGH VOLTAGE (BLACK/YELLOW)**



**GROUND TERMINAL**



**READ THE USER MANUAL BEFORE USING THE UNIT**

## 2. GENERAL DESCRIPTION

The main purpose of the UPS is to protect sensitive and critical equipment from electrical disturbances that can compromise operation. Black-outs, brown-outs, variations in voltage and frequency, lightning, electrostatic discharges and rapid over voltages are phenomena found in all office and industrial environments and which cause damage to the hardware and loss of data.

Netys is an Uninterruptible Power Supply designed to power computers and connected peripherals, with the exception of any other electrical device (such as household appliances, television sets, stereo systems and video recorders).

### 2.1. INTRODUCTION

The characteristic feature of these UPS is the constant monitoring of the power supply which, duly filtered and stabilised (on models with AVR) and if considered suitable, is used to supply consumers. In cases of a mains failure or if the mains is considered to be outside limits accepted by the load, the inverter (the heart of the UPS) is activated immediately. Drawing on the power stored in the batteries, the inverter generates a voltage that instantly takes over from the mains without any disruption to the equipment connected. During operation under emergency conditions, the internal batteries discharge but are recharged again automatically when mains power returns.

Being hermetically sealed, the batteries do not require maintenance of any kind at any stage of their working life.

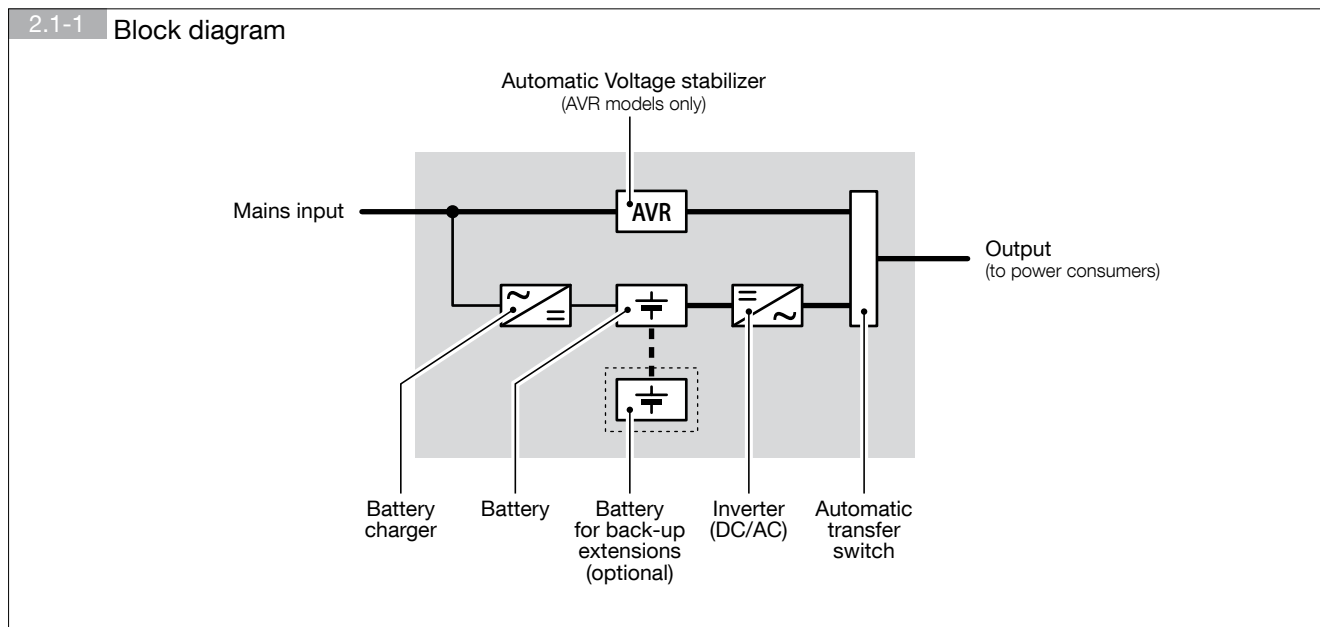

# 3. INSTALLATION

## 3.1. MOUNTING THE UPS IN A 19" RACK

3.1-1 Mounting Bracket for a 19" Rack

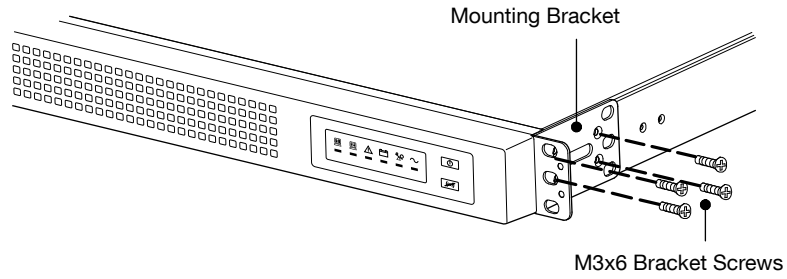

3.1-2 Adjusting the Rail Depth

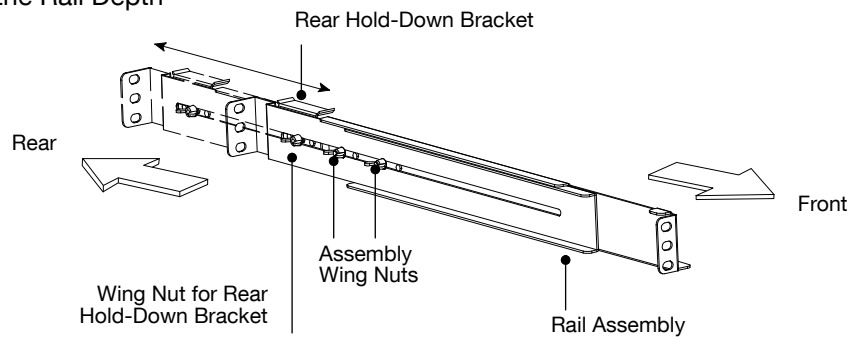

3.1-3 Securing the Rear Rail

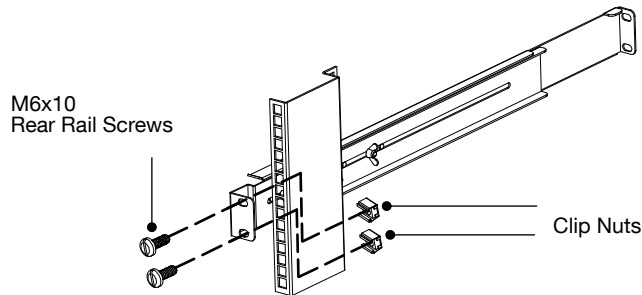

3.1-4 Securing the Front Rail

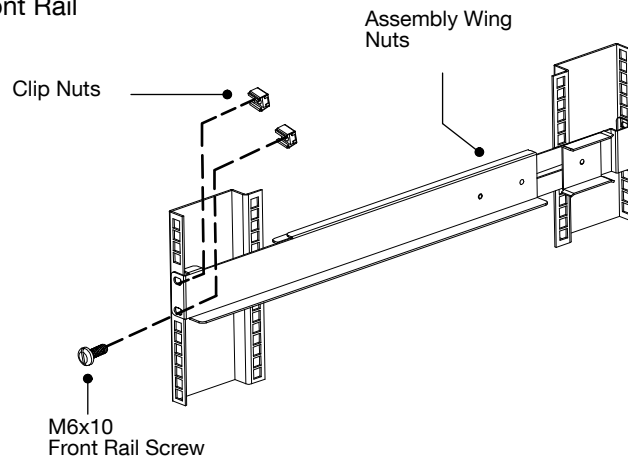

3.1-5 Securing the UPS in a 19" Rack

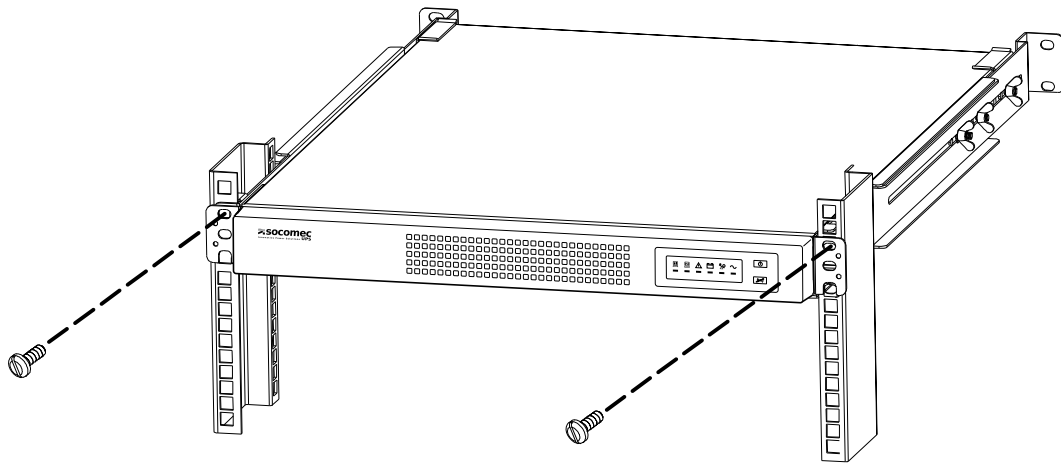

3.1-6 Rack Tray and Mounting Bracket for a 23" Cabinet

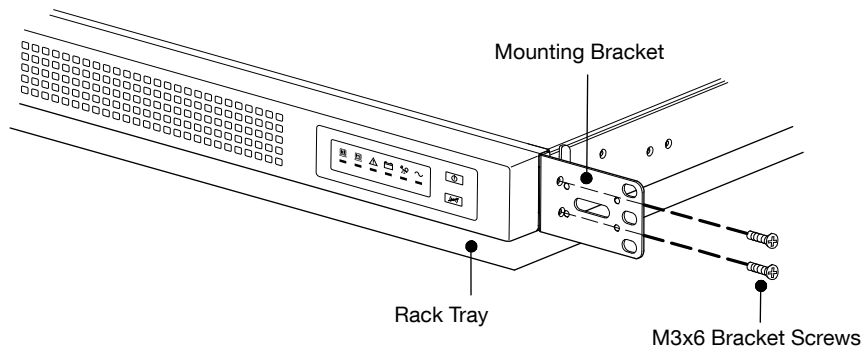

**NOTE**  
Rails cannot be used for 23" cabinets. Confirm that you have a rack tray.

3.1-7 Securing the UPS in a 23" Rack

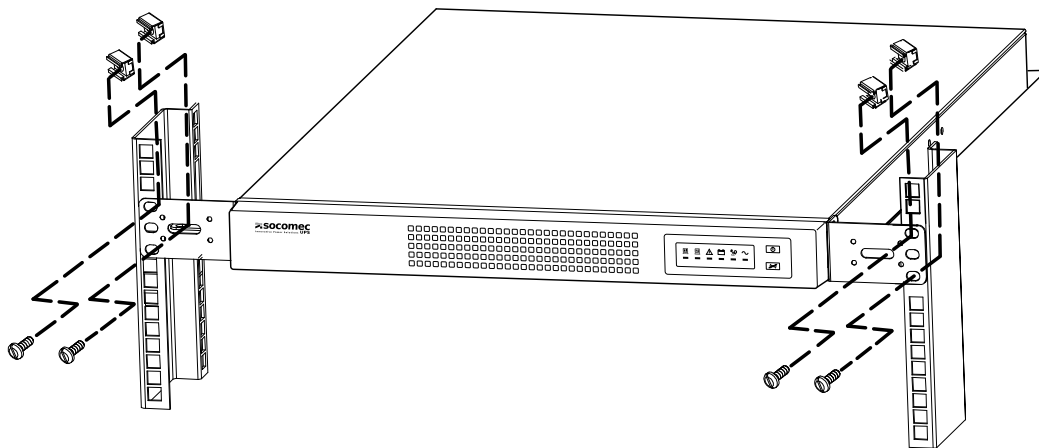

3.1-8 Zero-U Mounting

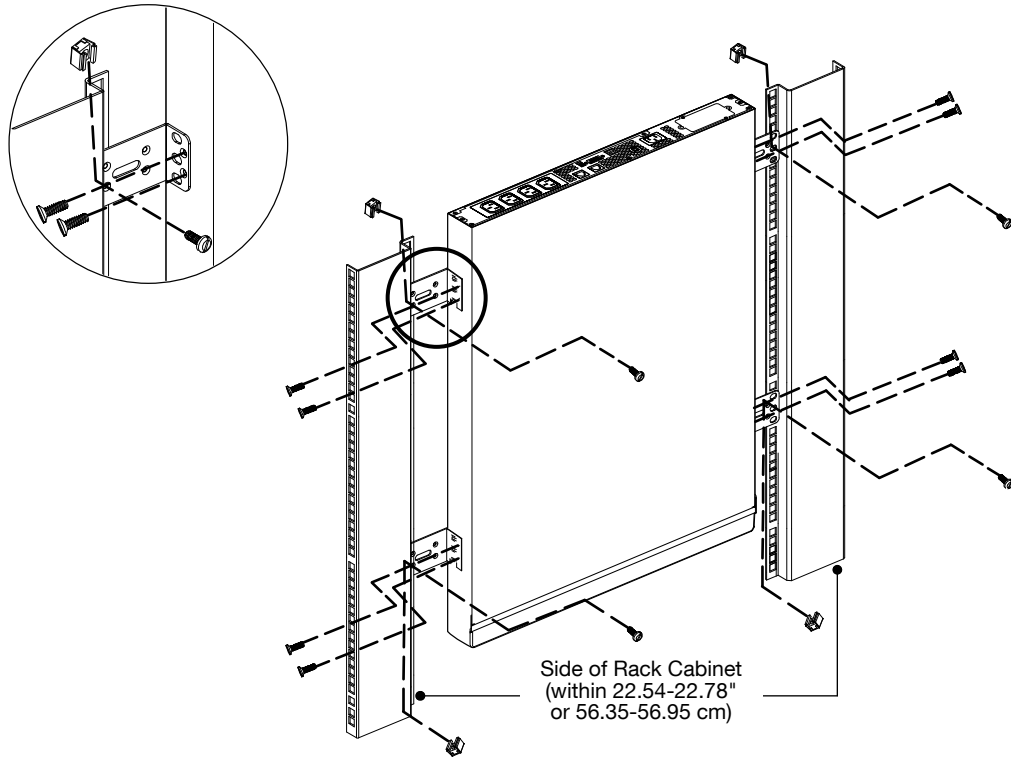

3.1-9 Mounting the UPS to a Wall

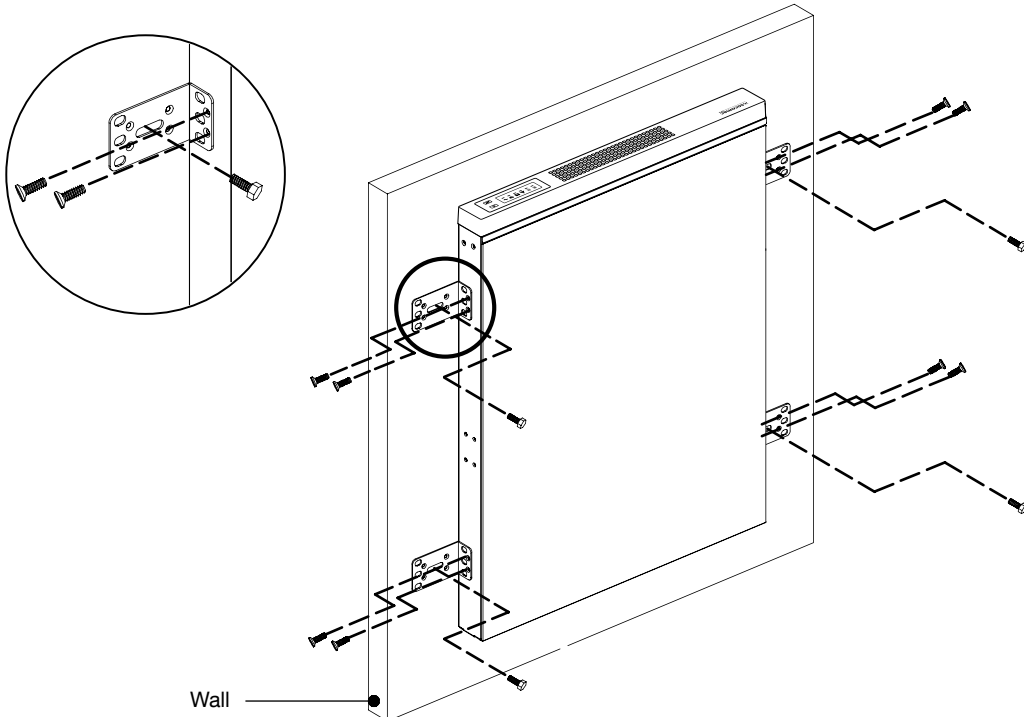

**WARNING!**

The UPS MUST be positioned with the front panel at the top to prevent a battery hazard.

# 4. FRONT VIEW

4.1-1 Front view

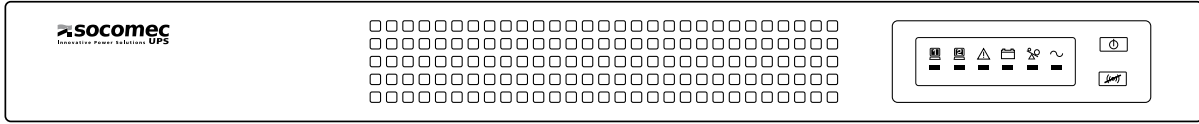

4.1-2 Control panel

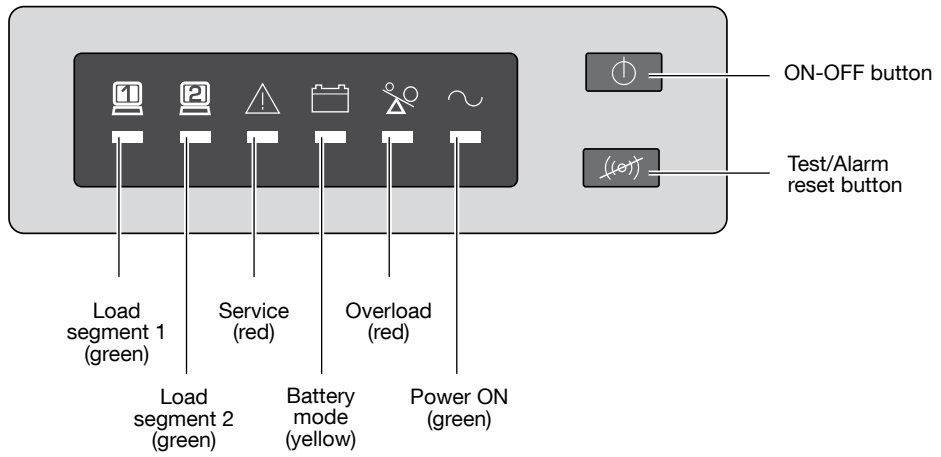

## 5. REAR VIEW

5.1-1 Rear view IEC 320

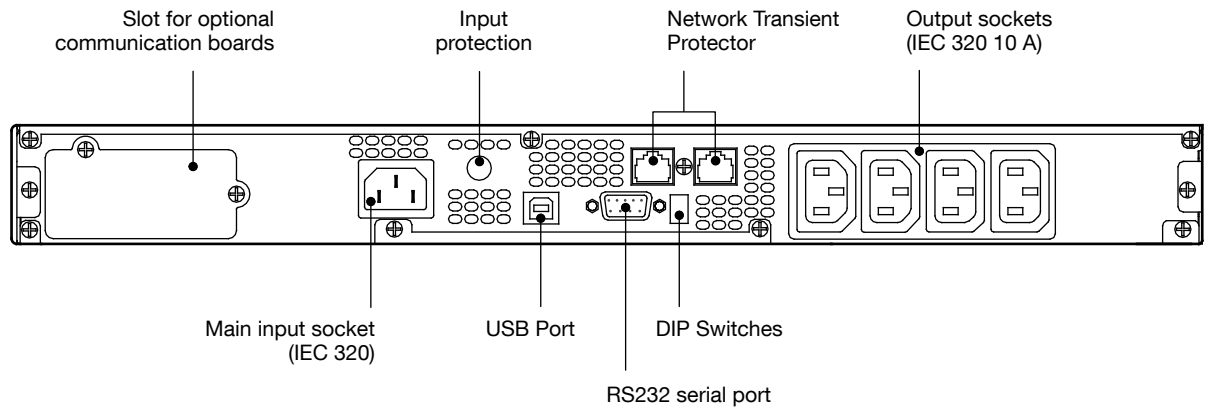

### NOTE

The batteries charge to 90% capacity in approximately 3 hours. However, it is recommended that the batteries charge for 6 to 24 hours after installation or long-term storage.

5.1-2 Rear view Australian standard

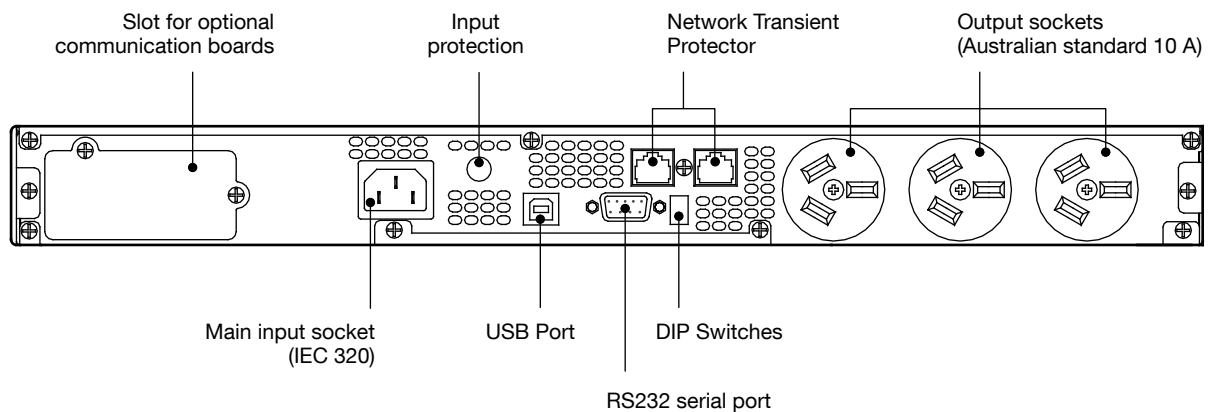

## 6. INTERNAL BATTERY CONNECTION

- Verify that the UPS is off and unplugged.
- Remove the UPS front panel (figure 6.1-1)
- Connect the battery connector (figure 6.1-2). A small amount of arcing may occur when connecting the batteries. This is normal and does not damage the unit or present any safety concern.
- Reinstall the UPS front panel.

6.1-1 Remove the UPS front panel

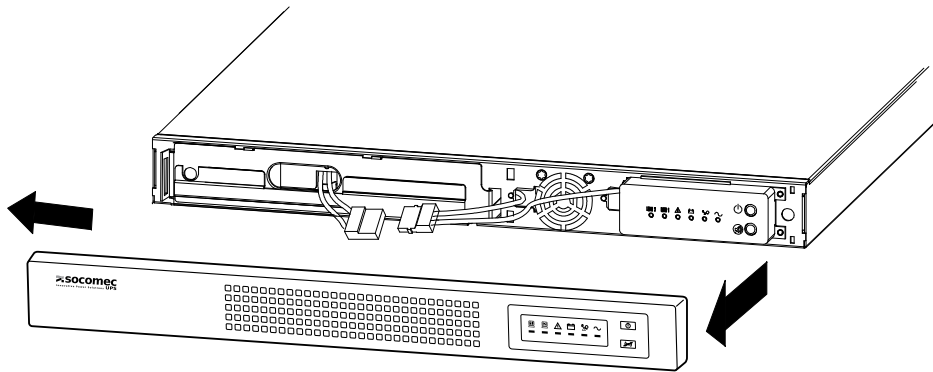

6.1-2 Connect the battery connector

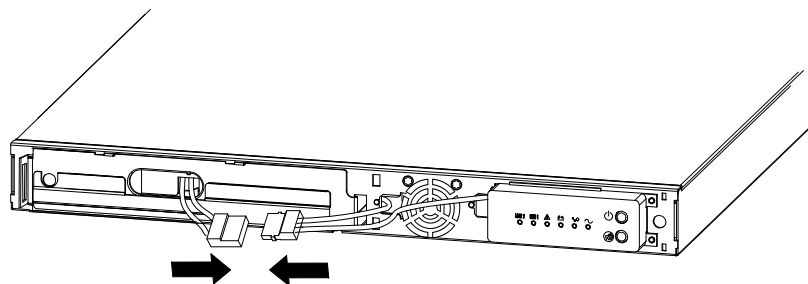

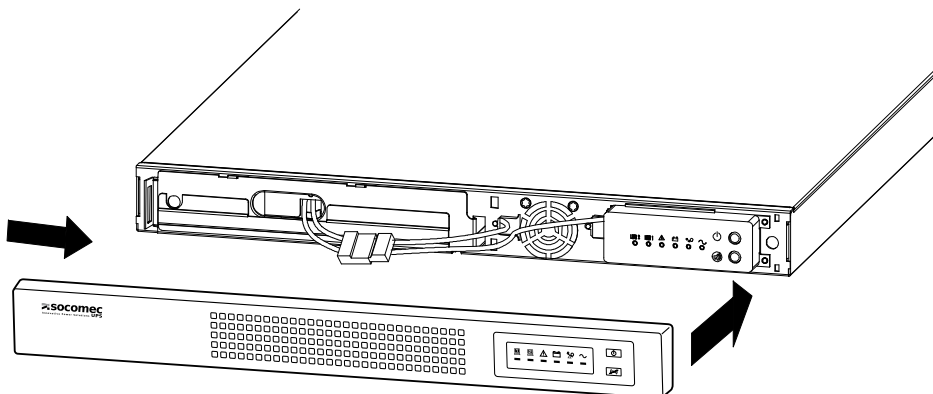

6.1-3 Reinstall the UPS front panel



# 7. MODES OF OPERATION

## 7.1. TURNING THE UPS ON

After the UPS is connected to a power outlet, the UPS enters Standby mode. To turn on the UPS, press and hold the  button until you hear the UPS beep (approximately two seconds). After the UPS is turned on, it conducts a self-test and enters Normal mode. The , Load 1, and Load 2 indicators illuminate indicating that power is available from the UPS output receptacles.

### Starting the UPS on Battery



#### NOTE

The UPS does not auto-detect the input frequency when starting on battery; the default is the last frequency used by the UPS.

To turn on the UPS without using utility power, press and hold the  button for two seconds. The UPS supplies power to your equipment and goes into Battery mode.

## 7.2. TURNING THE UPS OFF

To turn off the UPS, press and hold the  button for two seconds and then unplug the UPS from the power outlet. If you do not unplug the UPS, it remains in Standby mode.

## 7.3. STANDBY MODE

When the UPS is turned off and remains plugged into a power outlet, the UPS is in Standby mode. All indicators are off and power is not available to your equipment. The battery recharges when necessary.



#### NOTE

For 200-240V models, the output receptacles may remain electrically live (up to 100-120V). Unplug the UPS to ensure power is not available to the output receptacles.

## 7.4. INITIATING THE SELF-TEST



#### NOTE

The batteries must be fully charged and the UPS must not be in Battery mode to perform the self-test.

Press and hold the  button for three seconds to initiate the self-test. If the UPS finds a problem, an LED indicates where the problem is. For more information, see "Troubleshooting" on page 47.

# 8. ADDITIONAL UPS FEATURES

## 8.1. VOLTAGE CONFIGURATION

The DIP switches on the UPS rear panel (see Figure 14) are used to configure the output voltage and input voltage range.

1. The UPS must be completely shutdown. To turn off the UPS, press and hold the button for two seconds and then unplug the UPS from the power outlet.
2. Set the DIP switches according to the configurations in Table 1.
3. Plug the UPS into a power outlet.
4. Press and hold the button until you hear the UPS beep (approximately two seconds) to turn the UPS on.

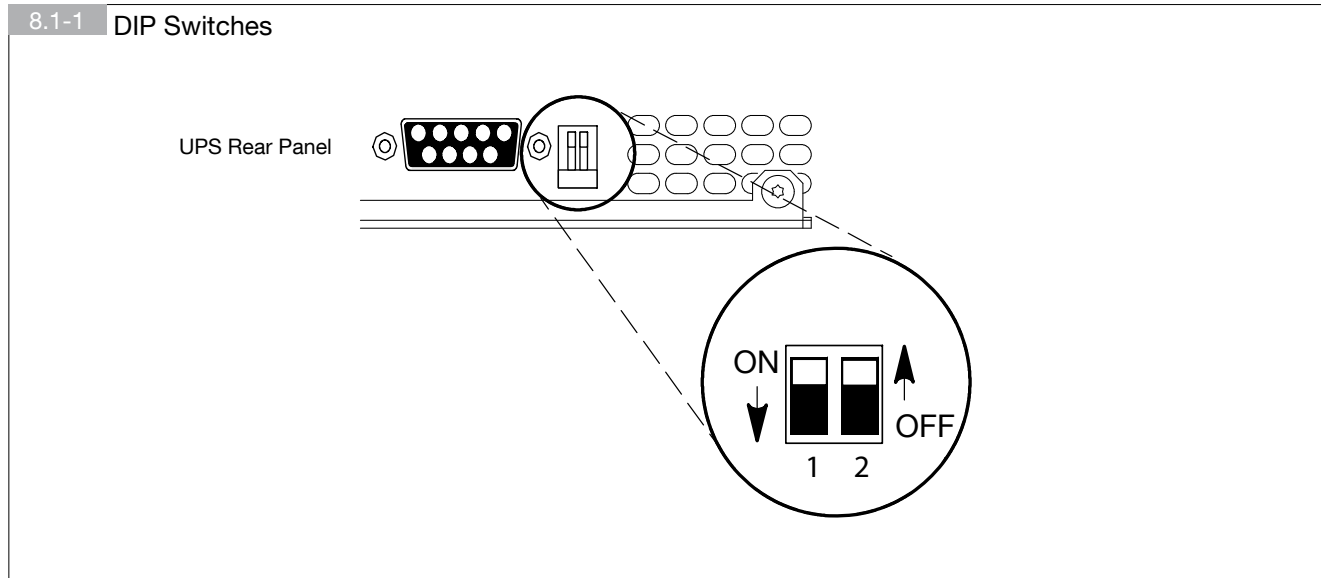

### DIP Switch Settings

230 V Models			
Output Voltage	Input Voltage Range	DIP Switch 1	DIP Switch 2
220 V	198 V-233 V	ON	OFF
230 V*	207 V-243 V*	OFF	OFF/ON
240 V	216 V-254 V	ON	ON

\*Default position

## 8.2. NETWORK TRANSIENT PROTECTOR

The Network Transient Protector is located on the rear panel and has jacks labeled IN and OUT. This feature accommodates a single RJ-45 (10BaseT) network connector.

Low voltage models can also accommodate an RJ-11 telephone connector that provides protection for modems, fax machines, or other telecommunications equipment. As with most modem equipment, it is not advisable to use this jack in digital PBX (Private Branch Exchange) environments.



**NOTE**

**DO NOT connect any telephone or fax/modem equipment to the 230 V models; only network protection is available for 230 V models.**

1. Connect the input connector of the equipment you are protecting to the jack labeled IN.
2. Connect the network or telephone cable (low voltage models only) to the jack labeled OUT.

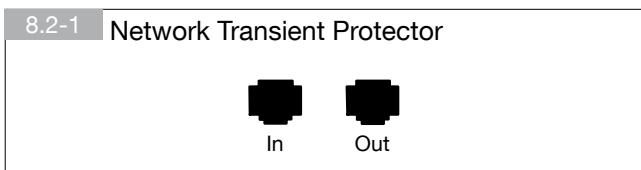

## 9. COMMUNICATION

The UPS provides excellent protection against interruptions or imperfections in the mains power supply. In these cases the computer (load) is powered by the UPS using battery power until this runs out.

Various software applications and communication options are available to optimise operation of the UPS and to correctly manage shutdown when back-up power ends. The status of the UPS can be monitored, keeping track of all the mains failures and battery discharges so as to activate an automatic and orderly procedure to close the programs and shutdown the system. When mains power returns the system will restart automatically.

All Netys models are equipped with RS232 and USB communication interface (USB not available on the Netys PR 1000 model).

### 9.1. COMMUNICATION SOLUTIONS

Depending on the model, there are different types of connections and software compatibility as shown in the table below:

- **Uni Vision:** local management software for local shutdown of Windows™ & Linux systems, free on [www.socomec.com](http://www.socomec.com) - RS232 interface
- **Uni Vision Pro:** network management software for local and remote shutdown: supports the major operating systems through Java Shutdown Client technology - RS232 interface
- **BMS:** possibility to integrate the UPS with BMS (Building Management Systems) - JBUS protocol
- **HID:** UPS management based on Windows™ embedded service - USB interface
- **NetVision:** Web/SNMP manager for UPS control over LAN with TCP/IP protocol. Allows remote shutdown through Java Shutdown Client technology - Web/SNMP card

### 9.2. RS232 INTERFACE

Communication with the server can take place directly via the RS232 interface.

In addition to local or networked shutdown it is possible to perform full monitoring of the electrical parameters regarding battery status and the automatic programming of the UPS start-up and shutdown procedures.

For a complete description of the software features, refer to the Uni Vision and Uni Vision Pro documentation.

### 9.3. USB interface

In addition to the RS232 serial link, it is also possible to establish communication directly through USB with the HID protocol, when this is available in the operating system. In this case, no SW needs to be installed. A standard USB cable is used and once this is connected, it is recognised just as any normal peripheral. The control parameters of the unit can be set directly via the operating system service menu.

### 9.4. NET VISION OPTIONAL CARD FOR SLOT

Net Vision permits direct connection of the UPS to a LAN (RJ45 Ethernet) and remote control of the UPS through TCP/IP using a WEB browser. For a complete description, refer to the Net Vision documentation.

### 9.5. USE OF WARNING RELAY INTERFACE

This is an optional card (slot-mounted) that will manage 5 indication circuits with isolated contacts carrying information on the status of the UPS. The maximum voltage that can be applied to the contacts is 240 VDC, and the maximum current 1 A.

Relay contacts can be set individually for NO (default) or NC operation, and programmed selectively for customized monitoring of the UPS.



#### WARNING!

The external contact **MUST** be dedicated and voltage-free, so as not to cause permanent damage to the UPS.

# 10. TROUBLESHOOTING

This section examines some of most likely problems that can compromise correct operation of the UPS, attempting to solve them and identifying the possible causes and remedies.



**WARNING!**

The UPS internally generates hazardous electrical voltages.

All maintenance must be performed solely and exclusively by authorized personnel.

If you have difficulty in getting the UPS to work, the reason may be among those listed below. For any other problem, you are advised to get in touch with your dealer or service organisation directly.

For quick and effective action, when you call it is important to give precise details of the defect, the model number and the manufacturing serial number that can be found on the conformance and inspection certificate or on the data plate on the bottom of the UPS.











*NOTE: the UPS has an audible alarm feature to alert you of potential power problems. Use Table 8 to determine and resolve the UPS alarms and conditions.*







## 10.1. SILENCING AN AUDIBLE ALARM

Before silencing an alarm, check the alarm condition and perform the applicable action to resolve the condition (see Table 8). To silence the alarm for an existing fault, press the button. If UPS status changes, the alarm beeps, overriding the previous alarm silencing.

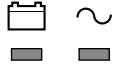
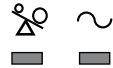
## 10.2. TROUBLESHOOTING

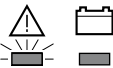
Legend:  = Unlit     = Lit     = Flashing

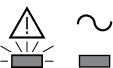
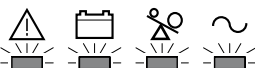
Alarm or Condition	Possible Cause	Action
The ~ indicator is not on; the UPS does not start.	The power cord is not connected correctly.	Check the power cord connections.
	The UPS is in Standby mode.	Press and hold the button until you hear the UPS beep (approximately two seconds) to supply power to the connected equipment.
	The wall outlet is faulty.	Replace the input fuse with another of the same type or reset the automatic switch.
The UPS operates in Battery mode only, even though normal utility power is present.	The input circuit protector is open (230V models only).	Save your work and turn off your equipment. Turn off the UPS. Reduce the load, then press the input circuit protector on the UPS rear panel.
The UPS does not provide the expected backup time.	The batteries need charging or service.	Plug the UPS into a power outlet for 24 hours to charge the battery. Press the  button; if the alarm beeps, see "Replacing Batteries" on page 40 to replace the battery. During extended power outages, turn off the UPS after saving your work and shutting down your computer to conserve battery power.
  ~   	Normal operation.	None. The UPS is operating in Normal mode and automatically provides consistent voltage with the Buck and Boost feature. Power is available to the load segments as indicated by Load 1 (Green) and Load 2 (Green).
  1 beep every 4 seconds.	The UPS is on battery due to a utility failure.	The UPS is powering your equipment with battery power. Prepare your equipment for shutdown. If this is an extended power outage, save your work and turn off your equipment to conserve battery power.
  1 beep every 2 seconds.	The battery is running low.	Two minutes or less of battery power remains (depending on load configuration and battery charge). Save your work and turn off your equipment. The alarm cannot be silenced.

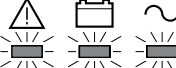
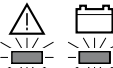
Alarm or Condition	Possible Cause	Action
 1 beep every 2 seconds.	The UPS is running on battery power because the input voltage is too high (>149V for 120V models; >290V for 230V models) or too low (<30V).	Correct the input voltage, if possible. The UPS continues to operate on battery until the condition is corrected or the battery is completely discharged.  If the condition persists, the input voltage in your area may differ from the UPS nominal.
 1 beep per second.	Power requirements exceed UPS capacity (overload is greater than 110%) or the load is defective.	The UPS will automatically shut down in 3 minutes. Save your work immediately and turn off your equipment. Turn off the UPS. The alarm cannot be silenced.  Remove some of the equipment from the UPS. You may need to obtain a larger capacity UPS.
 1 beep per second.	The UPS is on battery, and the power requirements exceed UPS capacity (overload is greater than 110%) or the load is defective.	Shutdown is imminent (30 seconds). Save your work and turn off your equipment. Turn off and unplug the UPS. The alarm cannot be silenced.  Remove some of the equipment from the UPS. Wait at least 5 seconds until all LEDs are off and restart the UPS. You may need to obtain a larger capacity UPS.
 Continuous beep.	Battery test failed.	Check the battery connections and be sure the battery is fully charged.  If the  indicator still flashes, see "UPS Maintenance" on page 39 to replace the battery. Call your service representative if the problem persists.
 Continuous beep.	UPS internal temperature is too high.	Shutdown is imminent. Save your work and turn off your equipment. Turn off and unplug the UPS. The alarm cannot be silenced.  Clear vents and remove any heat sources. Ensure the airflow around the UPS is not restricted. Wait at least 5 minutes and restart the UPS. If the condition persists, contact your service representative.
 Continuous beep.	UPS fan fault.	Save your work and turn off your equipment. Turn off and unplug the UPS. Contact your service representative. The alarm cannot be silenced.
 3 beeps every 10 seconds.	Failed attempt to start the UPS on battery.	Plug the UPS into a power outlet for 24 hours to charge the battery. After charging the battery, press and hold the  button for 3 seconds; then check the indicator. The alarm cannot be silenced.  If the  indicator still flashes, see "UPS Maintenance" on page 39 to replace the battery.
 Continuous beep.	The output wave is abnormal while the UPS is on battery.	Shutdown is imminent. Save your work and turn off your equipment. Turn off and unplug the UPS. Contact your service representative. The alarm cannot be silenced.
 Continuous beep.	The output voltage is below or above the limit while the UPS is on battery.	Save your work and turn off your equipment. Turn off and unplug the UPS. Contact your service representative. The alarm cannot be silenced.



If the equipment is to be left idle for a long period, wait for the batteries to charge fully before switching off. While the ups is left idle, make sure that the batteries are recharged for 24 hours at least once every 4 weeks.

# 11. TECHNICAL SPECIFICATIONS

Models	PR 1000 Rack 1U	PR 1500 Rack 1U
Power (VA)	1000	1500
Power (W)	670	1000
<b>Electrical specifications - Input</b>		
Voltage	230 V (default); 220 V, 230 V, 240 V selectable	
Frequency	45÷65 Hz, 50/60 Hz auto-sensing	
Mains connection	IEC 320 (10 A)	
<b>Electrical specifications - Output</b>		
Voltage (in Normal Mode with AVR)	•	•
Voltage (in Battery Mode)	Same as selected nominal input voltage: 220 V, 230 V, 240 V ±5% (-10% after Battery Low)	
Frequency	50/60 Hz	
Wave form	Sine wave	
Transfer time	2-4 ms (typical)	
Normal Mode protections	overload (110% for 3 minutes); shortcircuit protected	
Battery Mode protections	overload (110% for 30 seconds); shortcircuit protected	
Load connection socket IEC 320	(4) 10 A	
<b>Battery</b>		
Typical back-up time	12 minutes	
Battery recharge	Advanced charging for faster recovery. Approximately 3 hours to 90% usable capacity at nominal line and no supplementary power supply load).	
<b>Reporting and Communication</b>		
Communication interface	RS232 - USB	
Ethernet adapter	NET-VISION (TCP/IP & SNMP) optional card	
Local communication software	UniVision (management software)	
Remote communication software	UniVision Pro (management software)	
Data line protection	NTP data line suppressor: RJ45 10 Base T	
<b>Environment</b>		
Noise level (normal mode)	< 45 dBA (at 1 meter)	
Temperature	0÷40 °C (10÷25 °C for optimum battery life)	
Environment	Altitude: 2000 m, humidity: 95% non-condensing	
Reference standards	(EN) IEC62040-1-1 (safety), EN 62040-2 (EMC), EN 61000-4-5/C62.41:1991 (surge)	
<b>Mechanical characteristics</b>		
Dimensions (WxDxH mm)	440 x 578 x 44,5	
Net weight (kg)	21	23





# Socomec UPS worldwide

IN WESTERN EUROPE      IN EASTERN EUROPE, MIDDLE EAST, AFRICA      IN ASIA PACIFIC      IN AMERICA

**BELGIUM**  
Schaatsstraat, 30 rue du Patinage  
B - 1190 Bruxelles  
Tel. +32 (0)2 340 02 34  
info.ups.be@socomec.com

**FRANCE**  
95, rue Pierre Grange  
F - 94132 Fontenay-sous-Bois Cedex  
Tel. +33 (0)1 45 14 63 90  
dcm.ups.fr@socomec.com

**GERMANY**  
Heppenheimer Straße 57  
D - 68309 Mannheim  
Tel. +49 (0) 621 71 68 40  
info.ups.de@socomec.com

**ITALY**  
Via Leone Tolstoj, 73 - Zivido  
20098 San Giuliano Milanese (MI)  
Tel. +39 02 98 242 942  
info.ups.it@socomec.com

**PORTUGAL**  
Núcleo Empresarial de Mafra II  
Av. Dr. Francisco Sá Carneiro, Fracção N  
2640-486 Mafra  
Tel. +351 261 812 599  
info.ups.pt@socomec.com

**SPAIN**  
C/Nord, 22 Pol. Ind. Buvisa  
E - 08329 Teià (Barcelona)  
Tel. +34 935 407 575  
info.ups.sib@socomec.com

**THE NETHERLANDS**  
Duwboot 13  
NL - 3991 CD Houten  
Tel. +31 (0)30 760 0911  
info.ups.nl@socomec.com

**UNITED KINGDOM**  
Units 7A-9A Lakeside Business Park  
Broadway Lane - South Cerney  
Cirencester - GL7 5XL  
Tel. +44 (0)1285 863300  
info.ups.uk@socomec.com

**OTHER COUNTRIES**  
Tel. +34 935 407 575  
info.ups.europe@socomec.com

**UNITED ARAB EMIRATES**  
LJU-E17 DAFZA  
371355 Dubai airport free zone  
Dubai (United Arab Emirates)  
Tel.: +971 (0) 4 29 98 441  
info.ups.ae@socomec.com

**POLAND**  
ul. Mickiewicza 63  
01-625 Warszawa  
Tel. +48 22 825 73 60  
info.ups.pl@socomec.com

**ROMANIA**  
Heliade Intre Vii Street no.8, 2 District  
023383 Bucharest  
Tel. +40 21 319 36 88 ( 89, 81, 82)  
info.ups.ro@socomec.com

**RUSSIA**  
4th Street 8 Marta, 6A, 405  
125167 - Moscow  
Tel. +7 495 775 19 85  
info.ups.ru@socomec.com

**SLOVENIA**  
Savije 89  
SI - 1000 Ljubljana  
Tel. +386 1 5807 860  
info.ups.si@socomec.com

**TURKEY**  
Masuklar Yokusu No:57/2  
34357 Besiktas  
Istanbul  
Tel. +90 212 2580810  
info.ups.tr@socomec.com

**OTHER COUNTRIES**  
Tel. +39 0444 598 611  
info.ups.emea@socomec.com

**AUSTRALIA**  
Unit 3, 2 Eden Park Drive (Rydecorp)  
Macquarie Park NSW 2113  
Tel. +61 2 9325 3900  
info.ups.au@socomec.com

**CHINA**  
Universal Business Park  
B33, Floor 3, 10 Jiuxianqiao Lu,  
Chaoyang, Beijing 100016 P.R., China  
Tel. +86 10 59756108  
info.ups.cn@socomec.com

**INDIA**  
B1, IInd Floor, Thiru-Vi-Ka-Industrial Estate  
Guindy  
Chennai - 600 032  
Tel. +91 44 3921 5400  
info.ups.in@socomec.com

**MALAYSIA**  
31 Jalan SS 25/41- Mayang Industrial Park  
47301 Petaling Jaya.- Selangor, Malaysia  
Tel. +603 7804 1153  
info.ups.my@socomec.com

**SINGAPORE**  
31 Ubi Road 1 #01-00 (Lobby B)  
Aztech Building  
Singapore 408694  
Tel. +65 6506 7600  
info.ups.sg@socomec.com

**THAILAND**  
No.9 Soi Vibhavadirangsit 42  
Vibhavadirangsit Rd, Ladyao  
Chatujak Bangkok 10900  
Tel. +66 2 941-1644-7  
info.ups.th@socomec.com

**VIETNAM**  
539/23 Luy Ban Bich St.,  
Phu Thanh Ward, Tan Phu Dist  
Ho Chi Minh City  
Tel. +84-839734.990  
info.ups.vn@socomec.com

**ASIA PACIFIC HEAD OFFICE**  
Tel. +65 6507 9770  
info.ups.apac@socomec.com

**LATIN AMERICAN COUNTRIES**  
Tel. +34 935 407 575  
info.ups.sib@socomec.com

## HEAD OFFICE

**SOCOMECS GROUP**  
S.A. SOCOMECS capital 11 149 200 € - R.C.S. Strasbourg B 548 500 149  
B.P. 60010 - 1, rue de Westhouse - F-67235 Benfeld Cedex

**SOCOMECS UPS Strasbourg**  
11, route de Strasbourg - B.P. 10050 - F-67235 Huttenheim Cedex - FRANCE  
Tel. +33 (0)3 88 57 45 45 - Fax +33 (0)3 88 74 07 90  
admin.ups.fr@socomec.com

**SOCOMECS UPS Isola Vicentina**  
Via Sila, 1/3 - I - 36033 Isola Vicentina (VI) - ITALY  
Tel. +39 0444 598611 - Fax +39 0444 598622  
hr.ups.it@socomec.com

## SALES, MARKETING AND SERVICE MANAGEMENT

**SOCOMECS UPS Paris**  
95, rue Pierre Grange  
F-94132 Fontenay-sous-Bois Cedex - FRANCE  
Tel. +33 (0)1 45 14 63 90 - Fax +33 (0)1 48 77 31 12  
dcm.ups.fr@socomec.com

## YOUR DISTRIBUTOR



IOMNETPRXX01-GB 02 09.2012

[www.socomec.com](http://www.socomec.com)

Non contractual document. © 2012, Socomec SA. All rights reserved.

