

## Binary output 530BOD01

### RTU530 product line

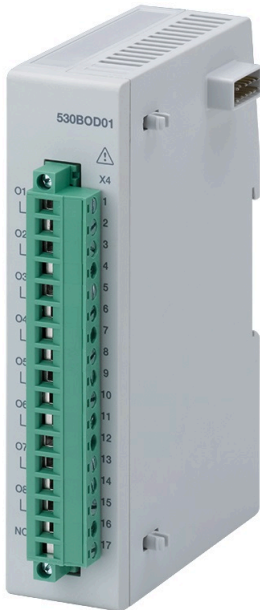

Binary output module with 8 channels, to be used for single commands, double commands, regulation step commands and digital setpoints

- 8 output contacts, 1-pole NO contact (high capacity relays), configurable as
  - 1-pole command
  - 2-pole command
- Max. Switching voltage (R0001): 150 V DC, 250 V AC
- Max. Switching voltage (R0002): 250 V DC, 250 V AC
- Continuous current: 5 A
- Individual output contacts, without common return

#### Application

The module 530BOD01 of the RTU530 product line can be used for the control of 8 binary process signals using relay contacts. The allocation of an output signal to the processing functions can be done according to the rules of configuration.

The module 530BOD01 is able to process the following types of signals:

- Single or double commands (SCO or DCO) with 1 or 2 pole output
- Regulation step command (RCO), 1 or 2 pole
- Digital setpoints commands, 8 Bit without strobe (DSO8)
- Bitstring output, 1, 2 or 8 Bit (BSO1, BSO2 or BSO8)

The module allows switching voltages up to 150 V DC, 250 V AC or max. 5 A continuous current.

The module is available in three versions (rubrics):

- 530BOD01 R0001 150 V DC
- 530BOD01 R1001 150 V DC, conformal coated
- 530BOD01 R0002 250 V DC Relay

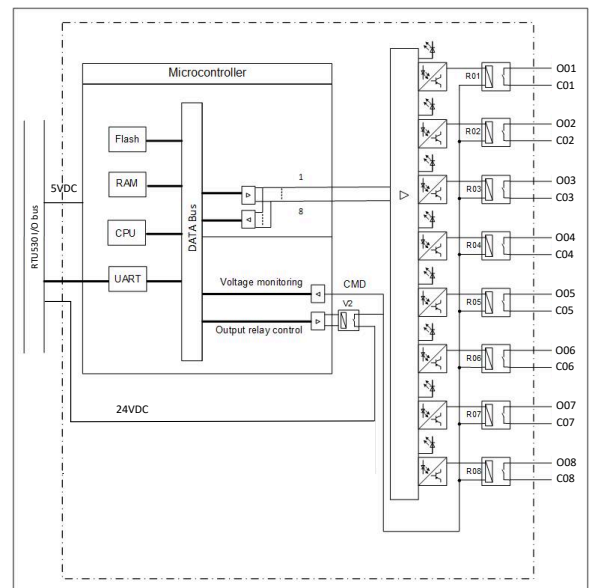

Figure 1: Block diagram of 530BOD01

## Characteristics

### Binary outputs

Relay contacts are used for the binary outputs.

The 8 outputs are isolated from one another and against the internal electronic. All 8 relays contacts have individual contacts without a common return.

The supply voltage for the coils of the relays (24 V DC) is switched by an internal switching transistor and is monitored internally before and during the command output.

Two output relays are required for each command in case of 2 pole commands.

Before and during command output the module 530BOD01 carries out several command monitoring functions. These tests ensure correct output.

If the command monitoring detects fault the command will be canceled. The switching through of the output relays by the release relay R17 occurs only after a successful test. A defective driver or a fault in the release relay R17 leads to complete inhibition of the command output module.

### Power supply input

The required power for the module is supplied via the RTU530 I/O bus connector.

### I/O controller (IOC)

The micro-controller (MPU) on the module processes all time critical I/O tasks of the parameterized processing functions. Moreover it carries out the interactive communication with the RTU530 I/O bus. All configuration data and processing parameters are loaded by the communication unit via the RTU530 I/O bus. Communication speed on the RTU530 I/O bus is 1 MBits/sec.

In connection with an I/O adapter (e. g. 530ADD01) or the RTU530 communication unit the module is interfaced to the RTU530 I/O bus.

The binary output unit can execute the following processing functions on the individual signal types:

- Control of the command output duration

Command monitoring functions:

- monitoring of the output bit patterns by reading back the output state
- switching voltage monitoring (24 V DC coil voltage) before and during output
- command output duration monitoring

During initialization and operation the module carries out a number of tests. If a fault occurs it is reported to the communication unit. A failure of the connected module(s) is detected and signalized by the communication unit.

## Technical data

In addition to the RTU500 series general technical data, the following applies:

### General standards

Safety tested according to	<ul style="list-style-type: none"><li>IEC 61010-1</li><li>IEC 61010-2-201</li></ul>
Environmental conditions tested according to	<ul style="list-style-type: none"><li>IEC 60255-21-1 class 1</li><li>IEC 60255-21-2 class 1</li><li>IEC 60870-2-2 class Bm and C1</li></ul>
Electromagnetic compatibility (EMC) tested according to	<ul style="list-style-type: none"><li>IEC 61000-6-2</li><li>IEC 61000-6-4</li><li>IEC 61000-6-5</li></ul>
Insulation classification according to	<ul style="list-style-type: none"><li>IEC 60664-1</li><li>Pollution degree 2</li><li>Overvoltage category II</li><li>Altitude: ≤ 3,000 m</li></ul>

### Environmental conditions - climatic

Operating temperature EN 60068-2-14	-25 °C ... 70 °C
Start up EN 60068-2-1	-40 °C
Max. operating temperature, max. 96h EN 60068-2-2	+85 °C
Relative humidity EN 60068-2-30	5 ... 95 % (non condensing)

### Environmental conditions - mechanical

Vibration sinusoidal, Test Fc, IEC 60068-2-6	3.5 mm (3 ... 9 Hz) 10 m/s <sup>2</sup> (9 ... 35 Hz) 1 octave/min, 1 cycle per axis IEC 60255-21-3 class 1
	3 mm (3 ... 9 Hz) 10 m/s <sup>2</sup> (9 ... 200 Hz) 15 m/s <sup>2</sup> (200 ... 500 Hz) 1 octave/min, 10 cycles per axis IEC 60870-2-2 class Bm
	0.035 mm (10 ... 60 Hz) 5 m/s <sup>2</sup> (60 ... 150 Hz) 1 octave/min, 1 cycle per axis IEC 60255-21-1 class 1
Shock and Bump, Test Ea, IEC 60068-2-27	250 m/s <sup>2</sup> , 10 ms 4 shocks per direction IEC 60721-3-3 class 3M5
	150 m/s <sup>2</sup> , 11 ms 3 shocks per direction IEC 60255-21-2 class 1 IEC 60870-2-2 class Bm
	100 m/s <sup>2</sup> , 16 ms 1000 shocks per direction IEC 60255-21-2 class 1

### Emission test

Radiated emissions - enclosure ports (30 Mhz to 1 GHz), CISPR 16-2-3/ EN 55016-2-3	EN 55011/ CISPR 11 class A
--	----------------------------

### Immunity test

Electrostatic discharge, IEC 61000-4-2	8 kV air / 6 kV contact (level 3), criterion A
Radiated radio-frequency electromagnetic field, IEC 61000-4-3	80 MHz to 1 GHz: 10 V/m (level 3), criterion A 1 GHz to 2.7 GHz: 10 V/m (level 3), criterion A
Power frequency magnetic field, IEC 61000-4-8	100 A/m (level 5), criterion A
Impulse magnetic field, IEC 61000-4-9	100 A/m (level 3), criterion A

### Mean time between failure (MTBF)

Calculation according to Telcordia III 40°C	6,923,317 h
---	-------------

### Mechanical layout

Dimensions	30 mm x 125 mm x 85 mm (Width x Height x Depth)
Housing type	Plastic housing (V-2), RAL 7035 light gray
Mounting	DIN rail mounting (EN 50022 TS35: 35 mm x 15 mm or 35 mm x 7.5 mm)
Enclosure protection class	IP30
Weight	0.2 kg

### Conformal coating

Material base	Acrylate resins (AR)
Standards	<ul style="list-style-type: none"><li>IPC-CC-830B</li><li>MIL-I-46058C</li><li>UL 94</li><li>UL 746E</li></ul>
Noxious gas protection (coating material)	Noxious gas test according to DIN EN 60068-2-60 or BMW GS 95003-4
Dielectric strength (coating material)	60 kV/ mm according to IPC-TM-650 or DIN EN 60243-1
Resistance to condensation (coating material)	1.0 x 10 <sup>10</sup> Ohm based on DIN EN ISO 6270-2

### Connection type

Process connector (X4)	1 x 17 pole 5.08 mm pluggable screw terminals (included in delivery), 0.2... 2.5 mm <sup>2</sup> / AWG 24 - AWG 12
Connector from CMU/ADD or other I/O module (X2)	2 x 6 pin, male
Connector to next I/O module (X3)	2 x 6 pin, female

---

**Current consumption for power supplied via RTU530 I/O bus**

---

5 V DC	100 mA
24 V DC	max. 90 mA

---

---

**Binary output channels 530BOD01**

---

Outputs	8 Relay contacts, single pole, normal open
Coil voltage	24 V DC @ 10 mA
Max. switching voltage	R0001: 150 V DC, 250 V AC R0002: 250 V DC, 250 V AC
Continuous current	5 A
Max breaking current (resistive load)	R0001: 5 A ≤ 30 V DC 1 A @ 60 V DC R0002: 0.3A@250 V DC
Max. breaking capacity (inductive load)	R0001: 13 VA (L/R= 20 ms) R0002: 20 VA (L/R= 20 ms)
AC dielectric voltage test, IEC 60255-27, IEC 61000-4-16, IEC 60870-2-1 (class VW3)	2.5 kV, 50 Hz, 1 min
Impulse voltage withstand test of insulation, IEC 60255-27, IEC 60870-2-1 (class VW3)	5 kV (1.2 / 50 μs)
Insulation resistance, IEC 60255-27	> 50 MΩ @ 500 V DC
Electrical fast transient / Burst, IEC 61000-4-4	4 kV (level 4), criterion A
Surge 1.2/50 μs, IEC 61000-4-5	4 kV (level 4)
Conducted disturbances, induced by radio-frequency fields, IEC 61000-4-6	10 V (level 3), criterion A
Ring wave, IEC 61000-4-12	2 kV line to earth, 1 kV line to line (level 3), criterion A
Conducted, common mode disturbances in the frequency range 0 Hz to 150 kHz, IEC 61000-4-16	30 V continuous disturbance/ 300 V short duration disturbance (level 4), criterion A
Damped oscillatory wave, IEC 61000-4-18	2.5 kV line to earth, 1 kV line to line (level 3), criterion A

---

---

**Signaling by LEDs**

---

O1... O8	LED displays the active output relays
----------	---------------------------------------

---

---

**Ordering information**

---

530BOD01 R0001	1KGT049900R0001
150 V DC	
530BOD01 R1001	1KGT049900R1001
150 V DC, conformal coated	
530BOD01 R0002	1KGT049900R0002
250 V DC Relay	

---