

WSC 204

(WSC 204 0102 / WSC 204MH 0102 / WSC 204KP 0102 / WSC 204BZ 0102)

Smoke control panel

Operating manual / Technical information



WSC 204 0102 – WSC 204BZ 0102
plastic housing



WSC 204KP 0102
plastic housing with integrated break glass unit



WSC 204MH 0102 steel housing

DK +45 4567 0300
 UK & IE +44 (0) 1536 510990
 DE +49 (0) 5221 6940 -500 Vertrieb / -650 Technik
 CH +41 (0) 62 289 22 22
 Other markets +45 4567 0300

info.dk@windowmaster.com
 info@windowmaster.co.uk
 info@windowmaster.de
 info@windowmaster.ch
 info@windowmaster.com

CE VdS   Mitglied im ZVEI Fachverband elektronisch betriebene Bauteile und reparaturabteilungen

www.windowmaster.com

Table of contents

1.	Safety information.....	3
2.	Technical description.....	4
2.1.	Accessories.....	5
3.	Operating elements and fuse review.....	6
4.	Function description.....	7
4.1.	Smoke and heat extraction.....	7
4.2.	Ventilation functions.....	8
4.3.	General information.....	9
4.4.	Connection possibilities.....	9
4.5.	Optional plug-in modules.....	10
4.6.	Back-up batteries charge.....	10
4.7.	Operation/ Setting possibilities.....	10
5.	Installation.....	11
5.1.	Surface mounting.....	11
5.2.	Countersunk mounting.....	12
5.3.	Cable routing.....	12
5.4.	Installation.....	12
5.5.	Installation of the Break glass unit, ventilation keypad and detector.....	13
6.	Cable dimensioning.....	13
6.1.	Cable length table.....	13
7.	Cable plan.....	14
8.	Wiring diagram.....	15
8.1.	Standard wiring diagram.....	15
8.2.	Wiring diagram WSC 204KP.....	16
8.3.	Various wiring diagrams.....	17
9.	Commisioning and troubleshooting.....	18
10.	Maintenance.....	20

1. Safety information

Attention!

Adherence to the following information is mandatory:

Only allow correspondingly trained, qualified and skilled personnel to carry out installation work.

Reliable operation and the avoidance of damage and hazards is only guaranteed if installation and settings are carried out carefully in accordance with these instructions.

Hazards to persons ensuing from flaps and wings operated by electric motors.

The forces occurring in the automatic mode can be such that parts of the body could get crushed. When opened, actuators could protrude into the room. For this reason, measures have to be taken prior to starting up the actuators, which exclude the danger of injury.

With wings tilting inwards or outwards, the wing must be protected from hinging down once the actuator is unhooked (e.g. for window cleaning).

For safety reasons we recommend the use of catching shears.

In the event that wings and flaps are subjected to rain or high wind loads, we recommend to connect a rain and/or wind detector to the smoke control panel, which will automatically close the flaps when comfort ventilation.

The house can be mounted either as counter sunk or surface.

The manufacturer does not assume any liability for possible damage resulting from inappropriate use.

230V AC dangerous voltage

Can cause death, severe injury or considerable damage to assets.

The connection of the control system is reserved for qualified personnel.

Disconnect all poles of the unit from the supply voltage prior to opening, installation or assembling. Adhere to national regulations.

Field of application

The central control system is exclusively designed for the automatic closing of smoke extraction systems, windows, flaps or doors.

Always check that your system meets the valid regulations.

Pay particular attention to the opening cross section, the opening time and opening speed. The cable cross sections depend on the cable length and current consumption (amperage).

Maintenance work

See last page in this instruction.

Cable routing and electrical connection

Fuse the 230V AC power supply cable separately on site.

Leave the insulation of the power supply cable in place up to the mains terminal.

Adhere to the DIN and VDE regulations (Germany) or equivalent in your country.

Establish the cable types, if necessary, with the local approval bodies or the fire protection authority.

Do not conceal flexible cables. Junction box must be accessible for maintenance purposes.

Disconnect all poles of the mains voltage and the accumulators prior to starting maintenance work or making changes to the system.

Secure the system to prevent unintentional switching on again.

Design cable types, lengths and cross sections in accordance with the technical information.

Route all low voltage cables (24V DC) separate from the power current cables.

2. Technical description

Function	<u>WSC 204 / WSC 204KP / WSC 204MH</u> <i>Opens the window actuators when triggered by a SHE-signal caused by smoke detector or break glass unit.</i>	
	<u>WSC 204BZ</u> <i>Closes the window actuators when triggered by a SHE-signal caused by smoke detector and opens the actuators when activating a break glass unit.</i>	
Supply voltage	230V AC / 50/60Hz ((±10%))	
Safety transformer	according EN 61558	
Power consumption	max. 150VA	
Actuator secondary voltage	rated voltage open circuit voltage at 230 VAC open circuit voltage at 253VAC actuator voltage at 230 VAC / 4.8A load ripple at full load (4.8A) open circuit voltage at battery operation	24V typ. 28V DC max 31.3V DC typ. 22V DC max. 6% (= 3.8Vpp) min 18.7V DC
Inrush current	Max 6A<5msec	
Standby consumption	4W	
Switch time between 230V- and battery operation	max 2.5sec	
Emergency power supply batteries	2 x 12V / 3,4Ah. Expected lifetime 4 years. (2pcs. WSA 003). Only use genuine WindowMaster back up batteries.	
Charging unit:	Charging voltage: 27,7 – 27,8 at 20°C Charging current: 350mA, current limited	
Operating duration (emergency power supply)	72 hours if batteries are fully charged (1,9Ah)	
Current load of the actuators (battery and 230V operation)	max. 4,8A	
Current load of the smoke unit (batteries, surveillance, periphery)	max. 0,7A	
Switch-on duration	40% ED	
Reopening the actuators	during the first 30 min. after a SHE-trig the actuators cyclically every 2 min.	
Review of fuses	mains 1A slow-blow actuator fuse 5A slow-blow battery 630mA medium slow-blow	
Type of connection to external	mains screw terminal / plug-screw terminals / 0.5-2.5mm ²	
Cable monitoring	automatic detectors (detector circuit with active end module), break glass unit (detector circuit with end resistor), actuators (with motor end module), batteries (cyclic measurement)	
Message OK, fault and alarm	optically alternating or steady signals by LED's: steady green LED = operating alternating yellow LED = malfunction of battery(at battery voltage less than 19V or above 29V), actuator, break glass unit or smoke steady red LED = alarm (short circuit)	
Automatic smoke triggering	Smoke triggering when temperature inside the compact unit exceeds 72°C	
Operating conditions	-5°C - 40°C, max. 90% relative humidity (not condensing)	
Approval / Certification	WSC 204 / WSC 204KP / WSC 204BZ: approved according to EN12101-10	
Protection type	<u>WSC 204 / WSC 204KP / WSC 204BZ</u> IP 30 (plastic housing)	
	<u>WSC 204MH</u> IP54 (steel housing)	

Housing	<p><u>WSC 204 / WSC 204KP / WSC 204BZ</u> Plastic house for flush. Delivered with a plastic frame for surface mounting. Protection class I Dimensions (WxHxD) 368x353x97/95mm Cut-out hole (WxHxD) 325±5 x 311±5 x min.80mm.</p> <p><u>WSC 204MH</u> Steel housing for surface mounting. 300 x 300 x 120mm.</p>
Delivery includes	Smoke control panel with 2 x 3,4Ah back-up batteries (2 x WSA 003).
Note	We reserve the rights to make changes

2.1. Accessories

Alarm and fault module (master slave)	WSA 301
Linking of wind/rain signal module	WSA 302
Timer ventilation module	WSA 303
Gap ventilation module	WSA 304B
ASV Module	WSA 306
Motor end module	WSA 432
Smoke detector end module	WSA 433
Replacement PCB without transformer for WSC 204 & WSC 204BZ	WSA 321 0102
Replacement PCB without transformer for WSC 204KP	WSA 327 0101
Transformer	WSA 328 0101
Locking cylinder with 2 keys for WSC 204, WSC 204BZ & WSC 204KP	WSA 440
Spare key for WSC 204, WSC 204BZ & WSC 204KP	WSA 441
Spare key for WSC 204MH	WSA 439

3. Operating elements and fuse review

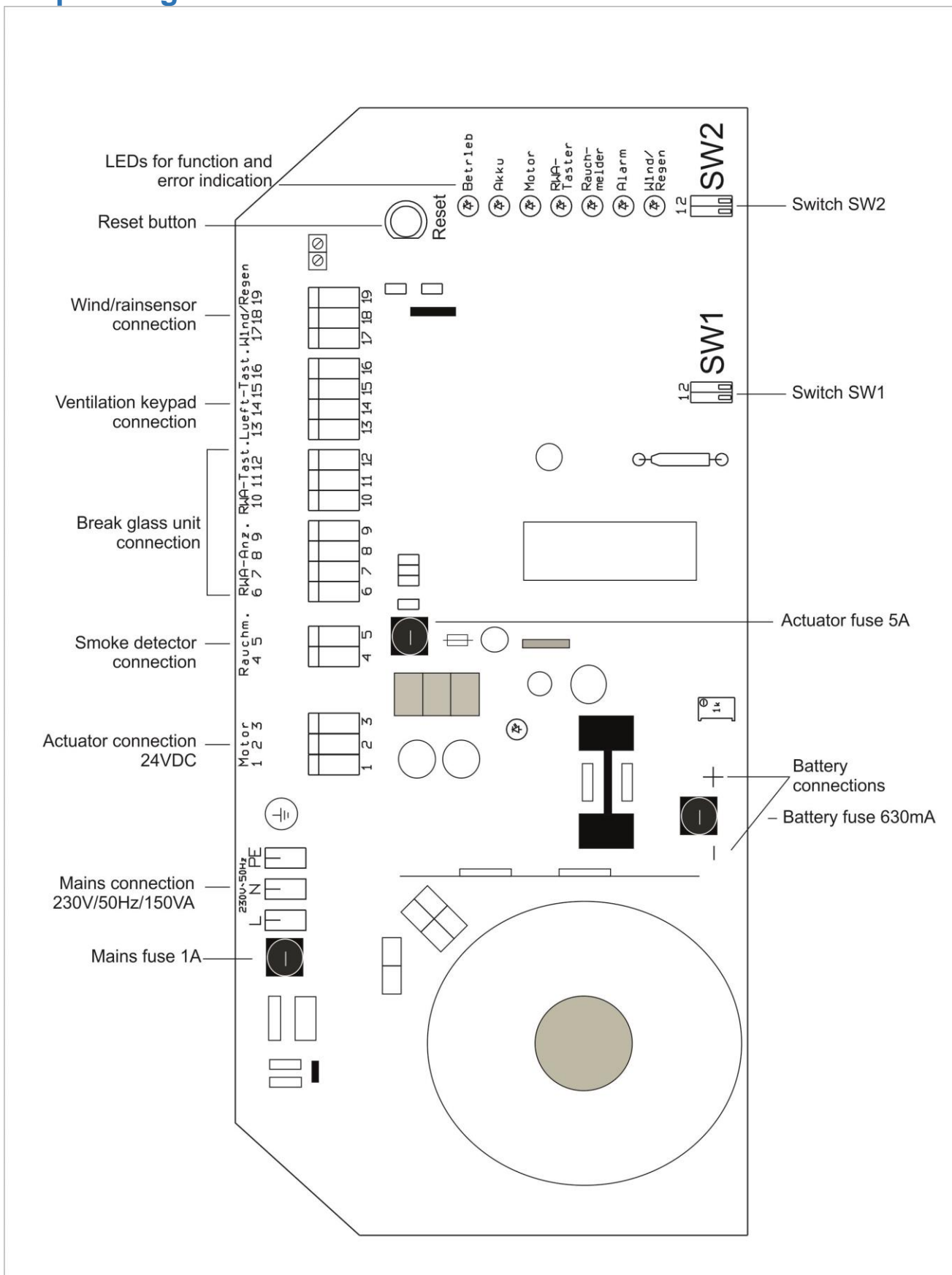

4. Function description

4.1. Smoke and heat extraction

Smoke and heat extraction system alarm trip

The acoustic signal will only sound in the primary break glass unit if the door is closed or if the door contact switch is pressed.

Break glass unit

Break the glass in the break glass unit! Press the red button min. 0.5 sec. The smoke extraction opens.

An acoustic alarm signal sounds (continuous sound) in the break glass unit.

All ventilation functions are out of operation.

Display: The red alarm LED in the smoke control panel and the red LED in the break glass unit are lit.

Smoke detector and heat detector

	Smoke and heat detector	Break glass unit
WSC 204 / WSC 204KP / WSC 204MH	Opens	Opens
WSC 204BZ	Closes	Opens

WSC 204 / WSC 204KP / WSC 204MH

If smoke / heat develop, the smoke extraction system automatically opens.

An acoustic alarm signal sounds (continuous sound) in the primary break glass unit.

All ventilation functions are out of operation.

Display: The red alarm LED in the smoke control panel, the red LED in the break glass unit, and the red LED at the tripped automatic detector are lit.

WSC 204BZ

If smoke / heat develops, the smoke extraction system automatically closes.

An acoustic alarm signal sounds (continuous sound) in the primary break glass unit.

All ventilation functions are out of operation.

Display: The red alarm LED in the smoke control panel, the red LED in the break glass unit, and the red LED at the tripped automatic detector are lit.

Reopening the actuators

The first 30 min. after a SHE-trig (on WSC 204BZ only when triggered the break glass unit) the actuators will be cyclically activated every 2 min in OPEN direction (to loosen frost fastened windows, domes e.g.).

Resetting a tripped smoke control panel

Press min. 0.5 sec. on the „CLOSE button“ in the break glass unit or on the „Reset button“ in the smoke control panel.

The acoustic alarm signal in the break glass unit stops sounding.

The ventilation functions are operational again once the smoke extraction system has closed.

(Prior to resetting, blow out or replace the detector after it was tripped by an automatic detector).

Display: The red alarm LED in the smoke control panel, the red LED in the break glass unit, and the red LED at the tripped automatic detector extinguish.

Change fuse after too high temperature

If too high temperature the yellow fault-LED in the break glass unit will flash and an acoustic pulse tone sounds (only if WSK 320). The green LEDs in the break glass unit and the smoke control panel will stop lighting.

Note

The built-in thermal switch is destroyed. The smoke control panel has to be returned for checking.

Alarm trip caused by a malfunction signal (SW2/1 to be switched to ON)

If the function is activated (ON), the smoke control panel will trip in the event of an actuator, smoke detector, blown temperature fuse or break glass unit circuit malfunction. An acoustic alarm signal sounds (continuous sound) in the break glass unit.

No trip occurs as a result of a malfunction in the mains or battery circuit.

If the temperature exceed 73°C the automatically SHE-alarm will be activated.

An acoustic alarm signal in the smoke control panel will start.

Display:

The red alarm LED in the smoke control panel and the red LED in the break glass unit are lit.
The yellow malfunction LED in the break glass unit and the corresponding yellow malfunction LED in the smoke control panel flash. The green operating LED stops lighting.

Option: Accumulative signalling of the alarm or malfunction signal (module WSA 301)

It is possible to send an alarm or malfunction signal potential free, by plugging in the alarm/malfunction signalling module.

The sending of the alarm can be stopped. If this is done, the yellow LED on the module will lit.

Multi malfunction warning

1 x change-over contact (max. load: 60V, 1A) with 3 pole connection terminal for potential free transmission to the BMS / panel etc.

2 pole connection terminal for 2 wire BUS cable for the feedback of malfunctions in cascaded control units to the break glass unit connected to the master smoke control panel.

Alarm message

1 x change-over contact (max. load: 60V, 1A) with 3 pole connection terminal for potential free transmission to BMS / panel etc., or as monitored 2 wire alarm cable for cascading control panels.

Jumper plugged in J1 = Only for the alarm transmission to the next smoke control panel (cascading).

Jumper plugged in J2 = pot.-free alarm contact (factory setting).

The transmitting can be interrupt. If so, it will be shown by the yellow LED.

Option: Cascading smoke control panels (module WSA 301)

The smoke control panels can be cascaded by a monitored 2 wire connection from the alarm module of the master smoke control panel to the smoke detector input of the slave central panel.

A malfunction in the cascaded smoke control panels is detected via the 2 wire BUS cable. The malfunction is only displayed in the corresponding smoke control panel and in the break glass unit connected to the master smoke control panel (primary break glass unit type WSK 320).

Option: ASV connection (module WSA 306)

The smoke detector input can be used for receiving a signal from an external fire detecting system (ASV). This requires a potential-free ASV contact and the ASV module WSA 306.

WSC 204 / WSC 204KP / WSC 204MH: ABA OPEN

To generate a trip (EMERGENCY OPEN) of the smoke ventilation group actuate the potential-free contact in the ASV. All smoke ventilation actuators "OPEN" automatically. An acoustic signal will sounds in the primary break glass unit (if mounted). The ventilation function/buttons are now out of operation.

WSC 204BZ: ABA CLOSE

To generate a trip (EMERGENCY CLOSE) of the smoke ventilation group actuate the potential-free contact in the ASV. All smoke ventilation actuators "CLOSE" automatically. An acoustic signal will sounds in the primary break glass unit (if mounted). The ventilation function/buttons are now out of operation.

The break glass unit has higher priority than ASV.

4.2. Ventilation functions

Ventilation OPEN

If the momentary function is activated (SW2/2 = ON), the actuators only move open for as long as the OPEN button of the ventilation button is kept pressed. (CLOSE still has self hold.)

If the latching function is activated (SW2/2 = OFF), the actuators open after pressing the OPEN button.

Display: The ventilation open LED in the ventilation button is lit (only with LED integrated in the button).

Ventilation stop

The actuators stop when both buttons are pressed.

Display: The ventilation open LED in the ventilation button remains lit (only with LED integrated in the button).

Ventilation closed

The actuators close after pressing the CLOSED button.

Display: The ventilation open LED in the ventilation button has extinguished (only with LED integrated in the button).

Option: Ventilation time module (time ventilation module WSA 303)

Automatic closing in the ventilation mode according to pre selected time (1 min. to 30 min.) after ventilation OPEN or STOP was actuated. Once this time has elapsed, the actuators close after ventilation „OPEN“ or ventilation „STOP“. This function is not operative if the setting potentiometer is on the right-hand stop.

Option: Gab ventilation module (module WSA 304B) WSC 204 / WSC 204KP / WSC 204MH

It is not always necessary for an electric actuator to open a ventilation unit (window or light dome) by its full stroke. Sometimes, a small gap is sufficient for ventilation purposes. This module enables time-controlled limitation of the actuator stroke (the opening time can on the potentiometer be set from 1 - 60 sec). Even re-triggered in "OPEN" direction the window will not open further than set preset opening value.

The module has no influence on the actuator when an "EMERGENCY OPEN" function is triggered. In this case the actuator opens to its maximum stroke.

It is **not** possible to install both a WSA 303 and a WSA 304B module in one smoke control panel.

Wind/rain CLOSE

The actuators close when the wind/rain sensor has been activated (potential free contact in the sensor switches).

As long as the sensor is activated, the ventilation function is out of operation and the green wind/rain LED lights.

Activated alarm has 1. priority.

Option: Transmission of the wind/rain signal (module WSA 302)

The activated signal of the wind/rain sensor can be transmitted potential free to the next smoke control panel.

1 x change-over contact (max. load: 60V, 1A) with 3 pole connection terminal for potential free transmission of the wind/rain trip.

CLOSE after a power failure

2 minutes after a power failure actuators opened for natural ventilation will automatically close. In the event of alarm, this function will be out of operation.

4.3. General information

EMC protection

All inputs and outputs are protected from coupled in electrical interferences.

Short-circuit protection

All outputs are protected against short-circuit and overload.

4.4. Connection possibilities

- | | |
|----------------------------------------------------------------------------------------------------------------------------------------------|-------------------------|
| 1) Actuators with a total power consumption of max. 4A | |
| 2) Smoke detectors, up to 10 pieces in 1 sensor group
Optical smoke detector and/or thermo-differential sensor
and/or heat max. sensor | WSA 300, WSA 310 |
| 3) Break glass units (main), up to 4 per sensor group | WSK 320 000X* |
| 4) Break glass units (secondary), up to 15 | WSK 330 000X |
| 5) Ventilation buttons with 'indicator, up to 15,
any number without 'open' indicator | WSK 100 1161 |
| 6) Wind/rain detector with potential free close contact | WLA 330 01, WLA 331 01 |
| 7) SHE activation on potential free
ASV contact in the smoke detector connector | WSA 306 to be installed |

* incl. the break glass unit in the door on the WSC 204KP

4.5. Optional plug-in modules

Module WSA 301 – alarm and fault module (master/slave)

Module WSA 302 – linking of wind/rain signal

Module WSA 303 - ventilation time module

Module WSA 304B – gab ventilation module (only WSC 204 / WSC 204MH)

Module WSA 306 – ASV module

4.6. Back-up batteries charge

Charging voltage: 27.7 – 27.8V at 20°C.

Charging current: is limited by the safety fuse 0,63A (F3).

Charging voltage disconnected in the event of a short-circuit .

Replace the emergency back-up batteries at least every 4 years!

4.7. Operation/ Setting possibilities

Operation / LED diagnose

Pushing the reset button on the circuit board the SHE activation is reset and the actuators closes.

Setting possibilities via slide switch SW1

SW 1/1 = ON	Statutory inspection activated
SW 1/1 = OFF	Statutory inspection indication not activated. After activation only a coded deactivation is possible. (Preset)

To show the activation the LED will flash 10 sec. If SW1/1 is once again set on OFF during these 10 sec., the prioritised activation is cancelled.

After a period of 12 month the inspection indication will be activated: the yellow fault LED in the main break glass unit will flash and the audible fault alarm will sound. The green operating LED will still flash to show that there is no fault. An alarm signal has first priority.

SW 1/2 = ON	Forwarding the alarm signal (WSA 301). After 3 min. it will stop.
SW 1/2 = OFF	Forwarding the alarm signal (WSA 301) as long as the alarm is triggered. (Preset)

Setting possibilities via slide switch SW2

SW 2/1 = ON	The SHE alarm trips when malfunction signal from actuator, smoke sensor, break glass unit, max. temperature sensor or blown temperature fuse.
SW 2/1 = OFF	No SHE alarm tripped when malfunction signal. Malfunction only shown on the LEDs. (Preset)

SW 2/2 = ON	The actuators only open for as long as the keypad is pressed (dead man control)
SW 2/2 = OF	The actuators will open if the keypad is activated (selfhold). (Preset)

Diagnosis / monitoring in the control unit and fault elimination

LED on the circuit board	LED colour	Function is OK	Malfunction	Diagnose
Netz (= mains)	green	Lit	Off	Check mains voltage and mains fuse (F1)
Betrieb (= operation)	green	Lit	Off	Check all functions in the board, main fuse F1
Akku (= battery / load control)	yellow	Off	Flashes when main failure or when charging voltage is under 26V. Lits when battery no connection, battery fuse defect, Battery voltage under 19V	Check main fuse and charging voltage. Check battery connection. Check battery fuse (F3) Check battery voltage
Motor (actuator circuit)	yellow	Off	Flashes when interrupted	Check actuator fuse (F2) and actuator end module
RWA-Taster (= break glass unit)	yellow	Off	Flashes when interrupted. Lits when short circuit.	Check wiring and jumper J1 in the last or only break glass unit.
Rauchmelder (= smoke detector)	yellow	Off	Flashes when interrupted. Lits when short circuit	Check wiring and the active end module.

Battery and actuator circuit malfunction be about 8 sec. delayed.

Operation / LED diagnose

Alarm (= alarm)	red	Lits when activated
Wind/Regen (= wind / rain)	green	Lits when activated

5. Installation

The smoke control panel has to be installed in a dry room.

5.1. Surface mounting

WSC 204 / WSC 204KP / WSC 204BZ

Mount the included frame on the smoke control panel and fix the panel to the wall through the four mounting holes on the back plate of the panel.

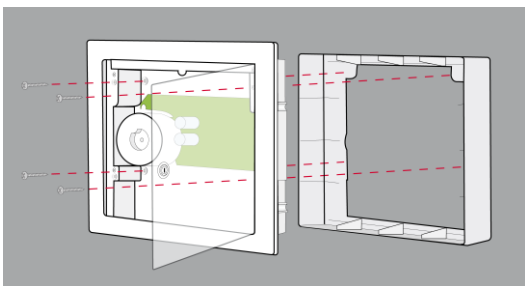

WSC 204MH

Open the smoke control panel and mount through the 4 holes on the back plate.

The wall must be suitable for the purpose.

Notice! Add gaskets on the screws between the panel and the wall to achieve the protection class IP54.

5.2. Countersunk mounting

WSC 204 / WSC 204KP / WSC 204BZ

The smoke control panel can be mounted countersunk in brick/concrete wall and timber frame wall.
Cut-out dimension WxHxD 325±5 x 311±5 x min. 80mm.

Brick/concrete wall



Bracket brick/concrete wall

Mount the brackets on the panel using the included screws – notice that the brackets can turn two different ways dependent on the finished thickness of the plasterwork.

Drill holes in the brickwork and fit raw plugs. Position brackets on face of brickwork and fix the screws.

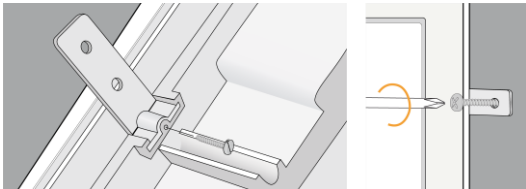

Timber frame wall



bracket for timber frame wall

Remove the door by pressing the small locking device.

Fix the brackets lightly on the back of the panel using the included screws – fix through the panel

Position panel and tighten screws.

Refit the door.

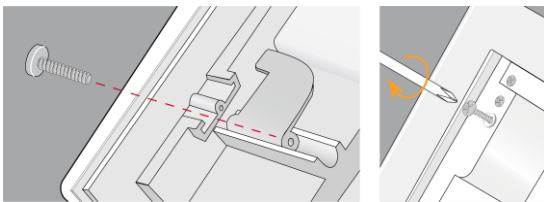

5.3. Cable routing

Observe the safety information on page 2.

For cable routing we recommend the use of fire protected cables retaining their function E90 or E30.

See also “Cable Length” page 12.

However, this has to be agreed with the Engineer or, if necessary, with the local fire protection department.

Do not reduce the cable cross sections specified in the cable lengths table.

All cables of the control (except the mains supply cable) carry 24V DC and have to be routed separate from the mains supply cable.

Adhere to the pertinent national and local regulations when routing the cables.

Do not use the green/yellow conductor.

Ensure that the mains cable can be switched via an external or customer-supplied two-pole switch element or a switch element controlling all poles.

5.4. Installation

Lead the connection cables into the housing of the control panel from above.

All connection terminals (except the mains terminals) are of the plug-in type.

Connect the connection cables in accordance with the terminal plan. Ensure that the connections are made correctly.

Incorrect clamping, mixing up numbers or colours could lead to malfunctions of the control panel or of the external components.

Ensure that the electrical cables are always routed according to the valid national and local regulations.

5.5. Installation of the Break glass unit, ventilation keypad and detector

Ensure that the break glass unit and the ventilation buttons are visible and well accessible.
Do not install behind protruding walls, door panels or hidden by the building structure.
Note: Installation height of the break glass unit = 1.4 m above floor.
Install the automatic detectors in accordance with their enclosed instructions.

6. Cable dimensioning

Maintaining the cable functions

According to valid national regulations.

The cable network for smoke ventilation systems („Cable system“) ends normally at the interface (junction box) for the actuator!

The flexible, heat resistant connection cable of actuator is part of the system component ‚electric motor actuation‘ and is not a part of the electrical installation!

We recommend in all cases to discuss the type of cable routing with the competent fire fighting authorities.

6.1. Cable length table

For determining the maximum permissible cable lengths between the smoke control panel and the actuators, taking into account the specified cables cross sections, please refer to the following table:

Maximum actuator current: 4.8A (**Note:** Be aware of the overall capacity of the smoke control panel!)

Actuating current: Sum of all motor currents per group module

Maximum cable length: (always routed from the central smoke control panel to the last junction box)

Note: Do not use the green/yellow wire!

Per motor supply line, 3 wires are required (2 wires current carrying /1 wire for monitoring)

Cross section	3 wire 1.5 mm ²	5 wire 1.5 mm ² (2 wires in parallel)	3 wire 2.5 mm ²	5 wire 2.5 mm ² (2 wires in parallel)	3 wire 4 mm ²
Actuator current in Amps					
1	84.00 m	168.00 m	140.00 m	280.00 m	224.00 m
2	42.00 m	84.00 m	70.00 m	140.00 m	112.00 m
3	28.00 m	56.00 m	47.00 m	93.00 m	75.00 m
4	21.00 m	42.00 m	35.00 m	70.00 m	56.00 m

(The information is valid for ambient temperatures of 25°C)

Formula for the calculation of the maximum cable length

max. cable length = $\frac{\text{permissible voltage drop } 2V \text{ (UL)} \times \text{conductivity of copper (56)} \times \text{cable cross section (A)}}{\text{max. actuator current total (I) in amps} \times 2}$

Permissible max. voltage drop in the line UL : 2 Volt

Permissible cable length for the break glass unit supply cable when using.....4x2x0.8mm: **up to 200m**

The motor connection cable length to the junction box (or control module) must not exceed **10 m**.

7. Cable plan

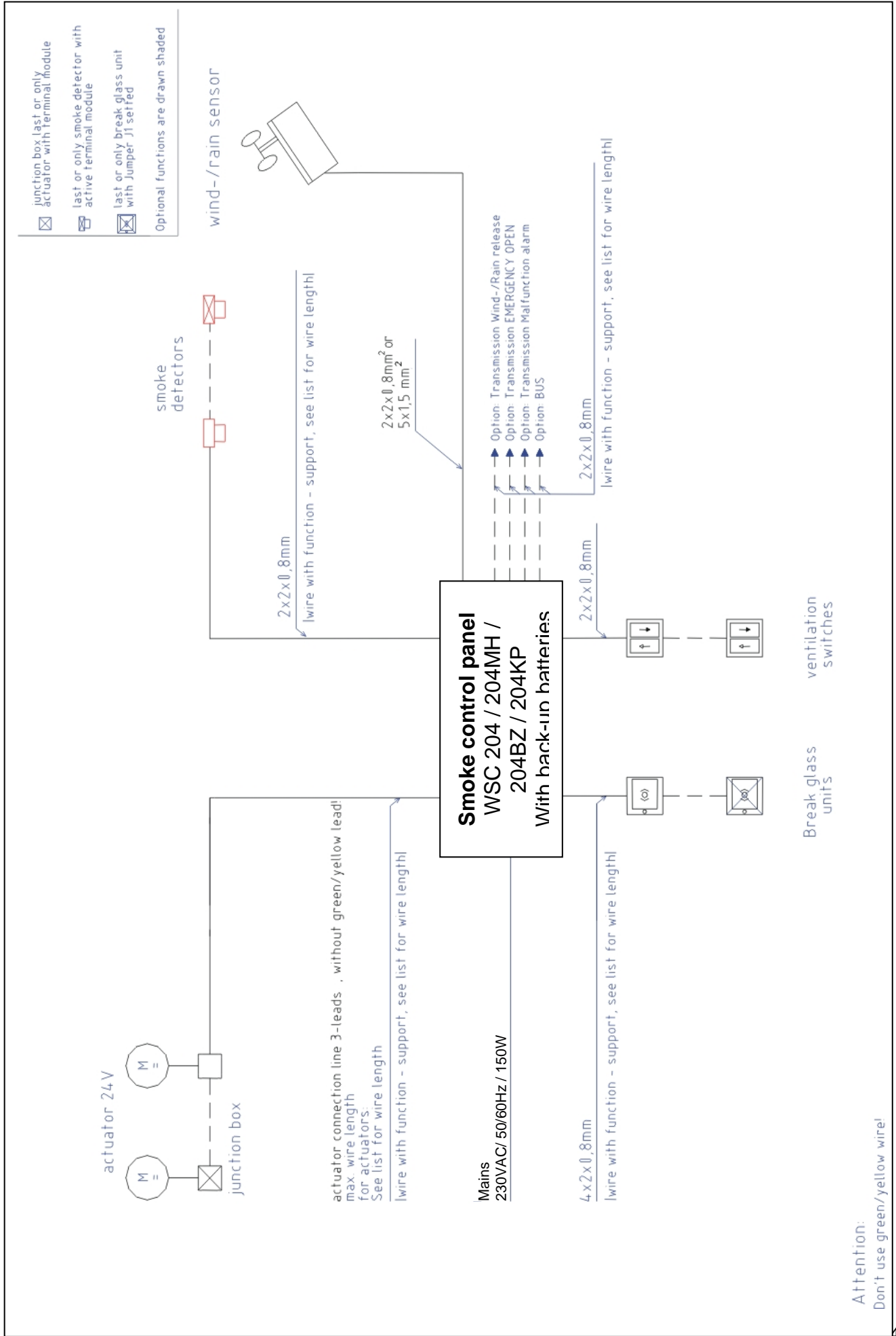

8. Wiring diagram

8.1. Standard wiring diagram

Wiring diagram Smoke control panel WSC 204

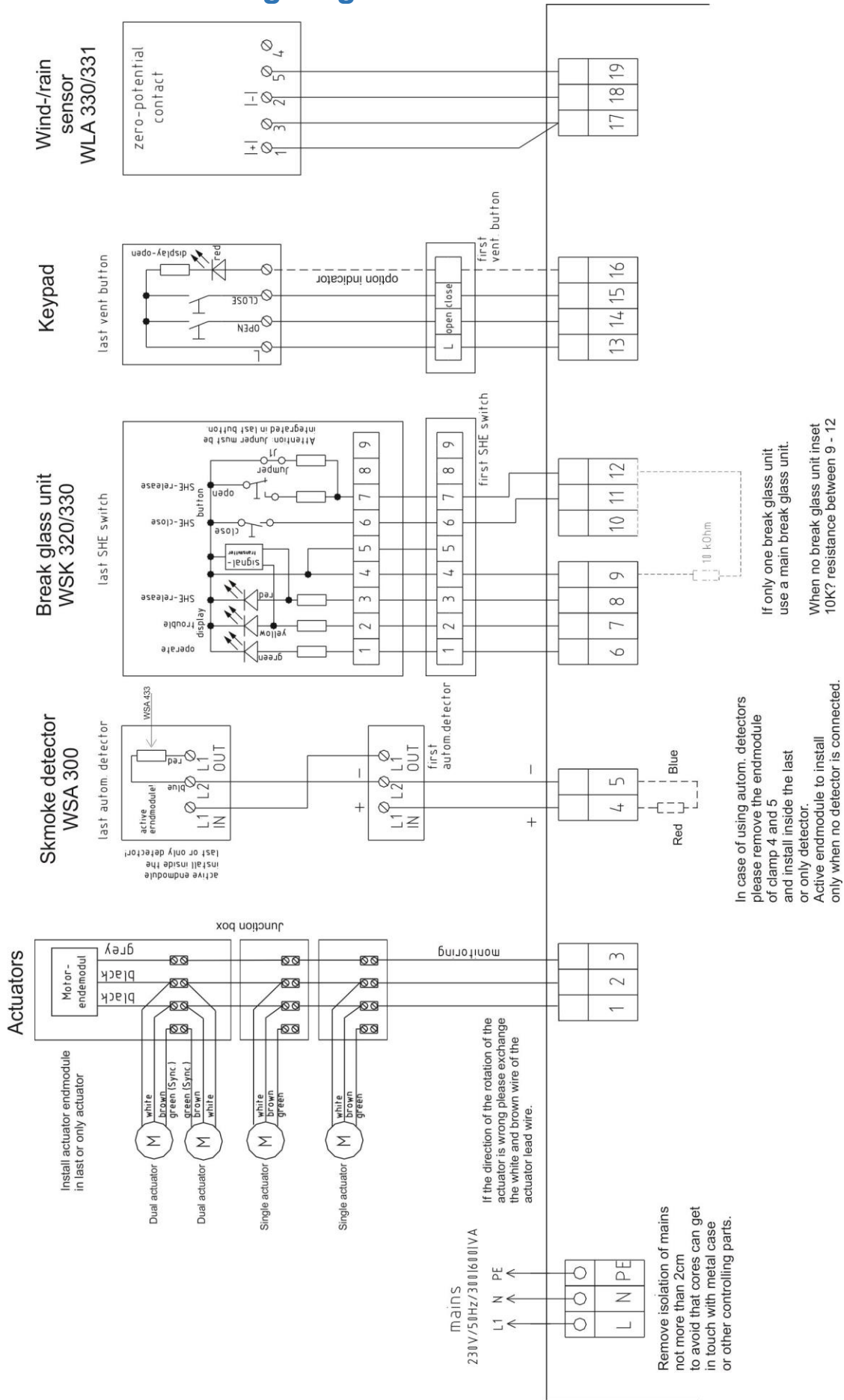

8.2. Wiring diagram WSC 204KP

Wiring diagram Smoke control panel WSC 204KP with additional break glass unit

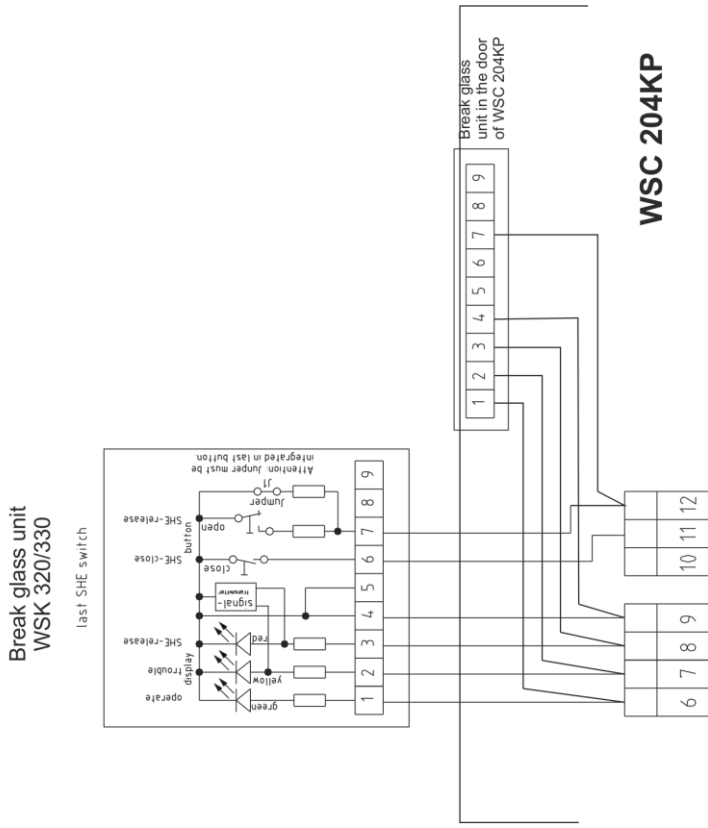

The door in the WSC 204KP
seen from the inside

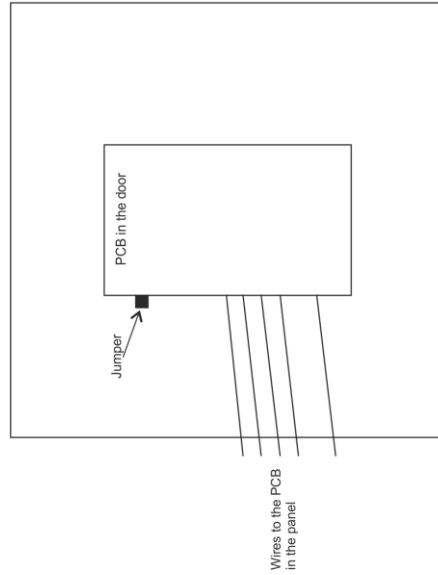

If one or more break glass units are to be connected to the WSC 204KP the jumper on the PCB in the door **MUST** be removed!

8.3. Various wiring diagrams

Wiring diagram Smoke control unit WSC 204 - autom. detector WSA 310 / ASV module WSA 306

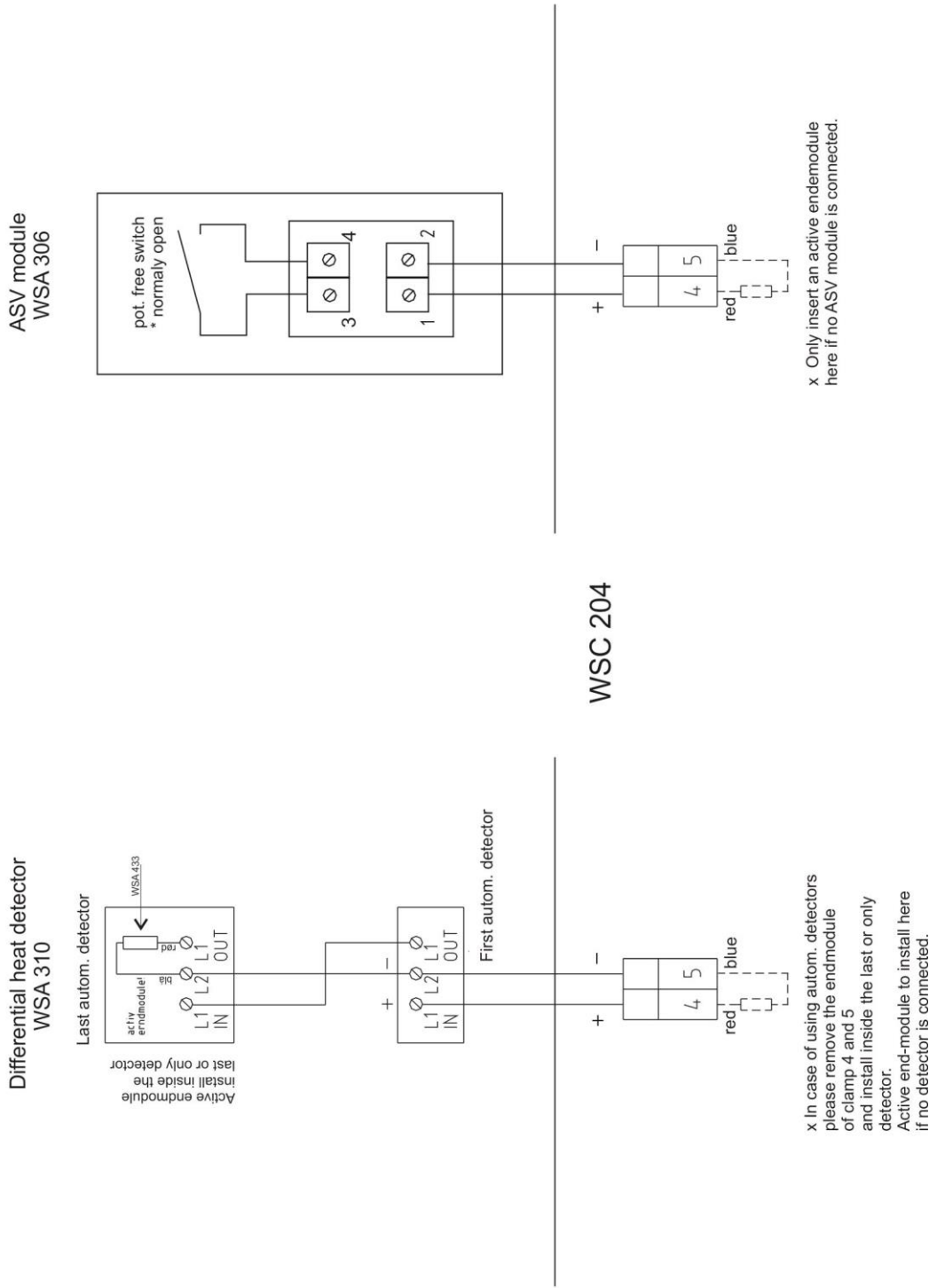

9. Commissioning and troubleshooting

When error message occur, please refer to chapter Function description see Operating elements/LED diagnosis.

An acoustic message only occurs in the SHE main operating panel with the door closed or the door contact switch pressed!

1) The control panel is completely installed, without the operating voltage applied

- a) Check all mechanical and electrical components for damage.
- b) Check the DIP slide switches in the control panel for their correct (required) position.
- c) Check all screw and plug connections for tightness and/or firm seating.
- d) Check that all external components are installed.
Actuators: Is the final module at the last or only actuator inserted?
Automatic detectors: Is the active end module at the last or only detector inserted?
Manual detectors: Is the jumper only inserted in the last or only operating panel?

2) With mains voltage, without accumulator

Adhere to the relevant regulations!

- a) Connect the mains cables and reapply the mains voltage.
- b) The mains LED is ON, the operating LED is OFF, the accumulator LED is ON. The malfunction message at the operating panels is ON.

3) With mains voltage, with accumulator

- a) Remove the protection film of the lateral adhesive tape for the 1.9 Ah battery, and firmly press the two batteries together according to the picture (next page).
- b) Remove the protection film from one face of the supplied foam rubber. Glue each foam rubber to the bottom side of the accumulators. Connect the accumulators to the black accumulator bridge according to the wiring diagram, then connect the red and the blue connection cable to the red and the black flat plug. Remove the bottom protection film of the foam rubber and insert the batteries in the control panel according to figure 1, and firmly press down to the housing bottom!
- c) Plug the red connection cable to the + and the blue connection to the flat plug of the control panel.
Note: Check correct polarity!
- d) The operating LED is ON, the accumulator LED is OFF. The malfunction message at the operating panels is OFF.

4) Ventilation keypad

Closely observe the actuators during opening and closing. They must not be impaired in any position by the building structure. Also the motor connection cables must not be subject to pulling or crushing.

- a) Briefly actuate the Open button to have the actuators move open up to the final position. With the SW2/2 =ON (hold-to-run) setting, the actuators only move as long as the button is pressed. The OPEN display (if existing) in the button is ON.
- b) Briefly actuate the CLOSED button, the actuators close. The Open display is OFF.
- c) Press both buttons simultaneously while running, this corresponds to stop. The ventilation Open display is ON, the actuators stop.
- d) Briefly press the Closed button again, the actuators fully close, the Open display is OFF.

5) Break glass unit, primary

- a) Open the door and press the red Open button. The actuators move open through to the end position. The red alarm LED (also in the control panel) is ON, at the same time a permanent acoustic signal sounds (door contact pressed!).
For the WSC 204KP, where the break glass unit is located in the door, the break glass unit must be exposed before the buttons can be pressed. To expose the break glass unit, the white plastic lever arm on the backside of the door must be turned counter clockwise, hereafter the glass can gently be pushed upwards and the break glass unit is exposed. When the glass is to be locked again, the lever arm is turned clockwise. This is only necessary when the break glass unit in the door is the only primary break glass unit and the signal cannot be deactivated from another primary break glass unit.
- b) While running, press the Closed button at the ventilation button, then press both buttons, the actuators must neither close nor stop!
- c) Press the reset/Closed button in the operating panel. The actuators close through to the end position. The ventilation function is released again. The red alarm LED (also in the control panel) and the signal generator are OFF.

6) Break glass unit, secondary

- a) Check as described under 5). „Operation“, „Malfunction“ and the acoustic signal are missing!

7) Automatic detectors

- a) Spray test aerosol on the detectors.
- b) The actuators move open through to the end position. The red LED in the detector, the red alarm LED (also in the control panel) and the permanent acoustic signal in the operating panel are ON.
- c) While running, press the Closed button at the ventilation button, then press both buttons, the actuators must neither close nor stop!
- d) Press the reset/Closed button in the operating panel. The actuators close through to the end position. The ventilation function is released again. The red alarm LED (also in the control panel) and the signal generator are OFF.

8) Emergency power supply test

- a) Remove the mains fuse from the control panel. Adhere to the VDE regulations! (only Germany - see National guidelines)
- b) The green mains and operating LED's are OFF, the yellow accumulator Led is flashing (control pabel in the accumulator mode).
The malfunction message at the SHE main operating panels panels is ON.
- c) The ventilation buttons are deactivated.
- d) If the actuators were open, they will automatically close after 2 minutes.
- e) Test the SHE trip and reset/closed as described under 5).
- f) Refit the mains fuse.
- g) The green mains and operating LED's are ON, the yellow accumulator LED is OFF. The malfunction message at the operating panels is OFF.

9) Activation of inspection check reminder

- a) Connect power and back-up batteries to the smoke panel.
- b) Connect all components to prevent fault signal.
- c) Set SW1/1 to ON..
- d) The operation LED flashes app. 10 seconds to control the activation.
- e) The maintenance reminder is now activated.

10) Wind/rain detector

- a) Open the actuators with the ventilation button.
- b) Wet the rain sensor, the actuators will fully close, the green wind/rain LED in the control panel is ON.
- c) While running, press the Open button at the ventilation button, then press both buttons, the actuators must neither open nor stop!
- d) The SHE trip has priority.

When the start-up was successful, then close the doors of the operating panels and of the control panel.

If the start-up was unsuccessful (error with one of the test run processes), please refer to the chapter Function description (see connection possibilities). If necessary, check the wiring in accordance with the wiring diagram.

11) Back-up batteries

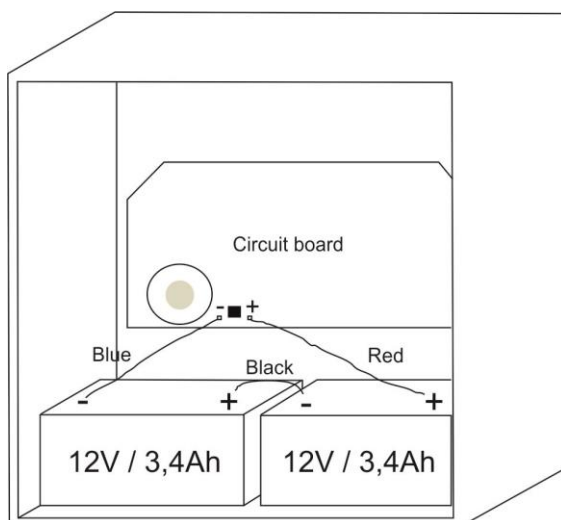

10. Maintenance

The panels of the smoke detection and heat extraction system have to be checked, serviced and, if necessary, repaired at least once per year by the manufacturer or an authorized system.

If a visual reminder regarding the yearly inspection is wanted, pls. see section "Commissioning and troubleshooting" part 9. After a period of 12 month the inspection indication will be activated: the yellow fault LED in the main break glass unit will flash and the audible fault alarm will sound. The green operating LED will still flash to show that there is no fault. A reminder will be given as a green and a yellow LED in the smoke panel and the break glass unit.

Remove all soiling from the units of the smoke and heat extraction system. Check fastening and clamping screws for firm seating.

Carry out a test run of the entire system (see chapters Start-up and Test Run).

Only have defective units repaired in our factory. Only install original spare parts.

Check the operational condition at regular intervals. We recommend a WindowMaster service contract is taken out to ensure the right function of the smoke and heat extraction system.

All back up batteries coming with the smoke control panel as standard; have to be subjected to regular checks. Within the framework of the service, they have to be replaced after the specified maximum 4 year operating period.

Adhere to the laws governing the disposal of hazardous substances (e.g. batteries).