

WMX 526 / 526 UL / 826 / 826 UL

Chain actuator



Description

- designed for surface mounting
- WMX 526 / 526 UL / 826 UL: for comfort ventilation
- WMX 826: for smoke and comfort ventilation
- to be used with top hung, bottom hung and turning windows
- to be used together with $\pm 24V$ control units or control units with MotorLink®
- can be used together with espagnolette WMB
- external safety edge can be connected directly to the actuator (actuator version 'E')
- available with and without ETL certification:
 - Europe: order without ETL certification
 - USA / Canada: order with ETL certification (version UL)
- synchronization of up to four window actuators – no need for an external synchronization module
- genuine position feedback and three speeds when using control unit with MotorLink®
- soft close function
- the electronics in this actuator can be programmed to suit specific requirements – i.e. pressure- and traction force, stroke, speed/sound level – with the WAT 100 programming box, also possible following installation
- built-in electronic load switch-off/end stop
- electronic actuator with micro controller
- the actuator has an integrated reverse function to ensure a prolonged life span of the window gaskets
- easy mounting

Actuator variants

The actuator is available in four different versions: single actuator (-1), double actuator (-2), triple actuator (-3) and quad actuator (-4).

The synchro actuators (-2, -3 and -4) are equipped with a patented synchronization function, in which the actuators communicate directly with each other, which ensures the actuators operate at exactly the same speed and position. On large windows up to four actuators can be mounted on the same window – with no need for an external synchronization module.

Pressure safety function

The risk of entrapment is reduced as the actuators are programmed to reverse if they encounter obstacles when closing. The set points determining when the actuators are to reverse are individually adjustable and can be adjusted also after installation using the programming box WAT 100.

Opening speeds

One speed:
Actuators connected to ± 24 VDC control units (e.g. WUC) can run with one speed – see the following page for opening speed.

Three speeds:

Actuators connected to control units with MotorLink® (e.g. WCC) can run with three different speeds:

- slow speed for soundless automatic control of the windows
- faster speed for audible manual (keypads) control of the windows
- fast speed for smoke ventilation and security functions

Technical specifications	
Pressure force	See diagram
Traction force	See diagram
Locking force	3000N
Chain stroke	50 – 500mm in increments of 10mm. Special version up to 600mm possible (only for bottom hung windows) – contact WindowMaster for further information.
Speed	WMX 526 / 526 UL: 7mm/s WMX 826 / 826 UL: 9mm/s (programmable 3 - 9mm/s)
Window type	Tophung, bottomhung and turning windows
Window width	Min. 700mm, maximum width depends on the window construction and the number of window actuators
Window height	Min. 700mm, maximum height depends on the window construction and the number of window actuators
Power consumption	24V DC (max. 10% ripple)
Voltage	20-36V DC
Open-circuit voltage	Max. 36V DC
Current consumption	WMX 526 / 526 UL: max. 0.5A WMX 826 / 826 UL: max. 1A
Operating conditions	-5°C - +74°C. Max. 90% relative humidity (not condensing)
Switch-on-duration	ED 40% (max. 4min. per 10min)
Material	Lacquered zinc house with 13mm zinc cromate passivated steel chain and 3-core 0,34mm ² cable with fast-in/fast-on connectors for connection to the extension cable WLL WMX 526 / 826: 4.9m grey silicone cable WMX 526 UL / 826 UL: 1.9m UL listed/recognized cable in grey (grey actuator) or white (white actuator)
Colour	Aluminium (RAL 9006) or white (RAL 9010), other RAL colours available at additional price
Size	487 x 30,5 x 42mm (W x H x D)
Weight	1,3kg
IP rating	Surface mounted: IP 20, concealed: IP 32
Certification	Actuators with 'U' in the article no. are ETL certified accordingly to UL 325 and CAN/CSA-22.2 No. 247-92 and is supplied with UL approved cables UL STYLE 2464
SHE test	WMX 526 / 526 UL /826 UL: not SHE tested WMX 826: tested in accordance with DIN 18232-3, section 3.6 (30 minutes at 300°C) and part B300 of BS EN 12101-2
Life span	Tested with 10,000 opening and closing movements
Delivery	WMX 526 / 826: actuator with 4.9m cable and fast-in/fast-on connector for WLL cable WMX 526 UL / 826 UL: actuator with 1.9m UL listed/recognized cable
To be ordered separately	Brackets and standard extension cables type WLL
Note	We reserve the right to make technical changes

Item code composition (actuator supplied in sealed plastic packaging)						
WMX 526	n	x	xxx	x	x	3
WMX 826						Product version: 3
						Certification: 0 = CE, U = CE + UL/ETL
						Actuator hardware version: S = standard, E = with connection for pressure safety strip (E: not UL actuator)
						Chain opening: 50 – 500mm, in increments of 10mm (050 = 50mm)
						Colour: G = grey, W = white
						Actuator variant: 1 = single, 2 = double, 3 = triple, 4 = quad
Explanation of product code structure						
WMX 526-2G070E 03	WMX 526 actuator, double synchronisation grey, 70mm chain opening, with connection for pressure safety strip, with CE certification, product version 3					

Item code composition (actuator supplied in sealed plastic packaging and cardboard box)						
The actuator is supplied with 500mm chain opening and actuator hardware version standard "S".						
WMX 826	n	x	01			03
						Product version: 03
						Market variant: 01 = for Europe
						Colour: G = grey, W = white
						Actuator variant: 1 = single, 2 = double
Explanation of product code structure						
WMX 826-2G 0103	WMX 826 actuator, double synchronisation, grey, for Europe, product version 3.					

Accessories	Item no.
Chain bracket with tight-fitting bolt, WMX, for sash or frame	WAB 801
Chain bracket with split, for sash or frame	WAB 860
Chain bracket for wooden windows, for sash	WAB 867
Angle bracket for actuator, grey RAL 9006	WAB 804 0101
Angle bracket for actuator, white RAL 9010	WAB 804 1101
Z bracket for actuator WMX 504/804/524/824/526/826. Sash min 800mm.	WAB 805
Actuator bracket for buttomhung window	WAB 845
Actuator bracket	WAB 824B
See separate product sheets for further information.	

Installation suggestion 1

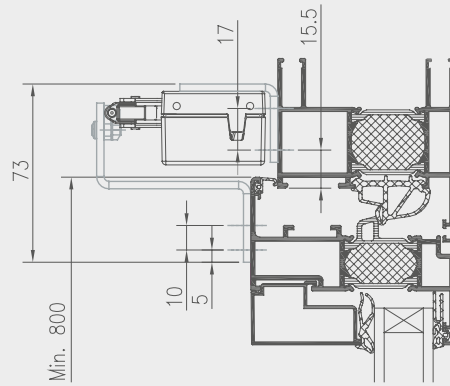

* The cable cover must face towards the window hinge!

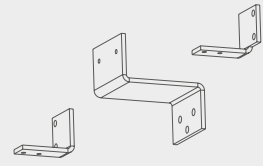

WAB 805

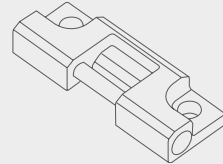

WAB 801

Installation suggestion 2

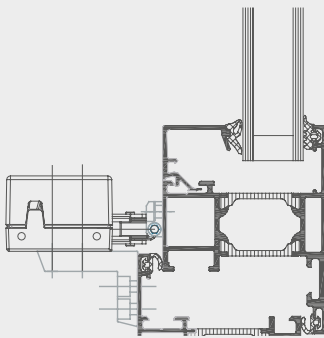

IMPORTANT!
Mount the actuator so the bottom of the housing faces towards the centre of the window

Installation suggestion 3

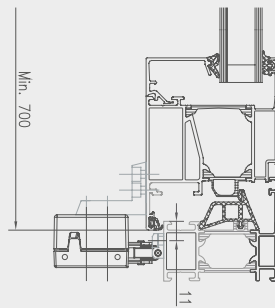

WAB 804 - 0101 grey / -1101 white

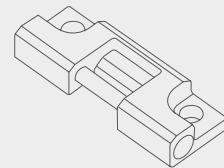

WAB 801

Installation suggestion 4

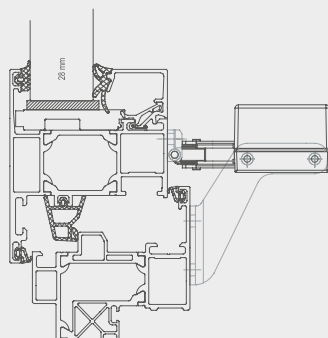

IMPORTANT!
Mount the actuator so the bottom of the housing faces towards the centre of the window

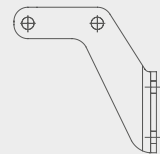

WAB 824B

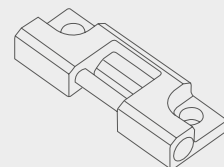

WAB 801

WMX 526 / 526 UL / 826 / 826 UL

Chain actuator

Installation suggestion 5

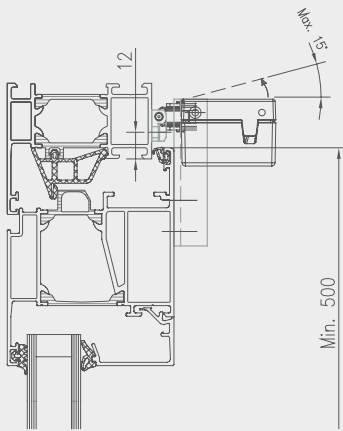

IMPORTANT! Mount the actuator so the bottom of the housing faces towards the centre of the window

Actuator with limited 15° rotation mounted:

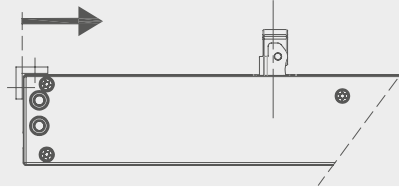

Actuator unlimited rotation mounted:

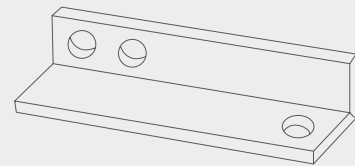
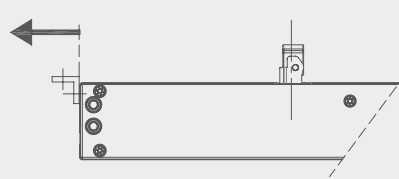

WAB 845

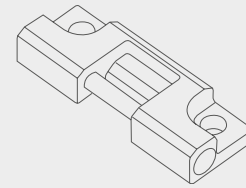

WAB 801

Installation suggestion 6

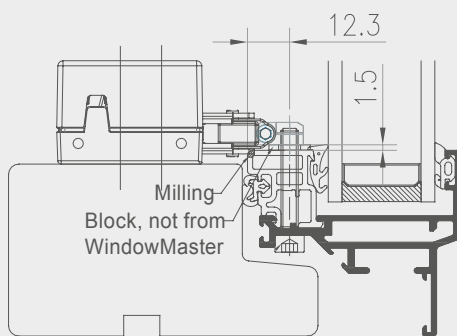

IMPORTANT! Mount the actuator so the bottom of the housing faces towards the centre of the window

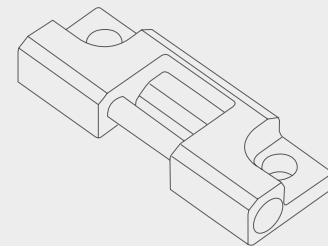

WAB 801

IMPORTANT!

Mount the actuator so the bottom of the housing (marked with a yellow label) faces towards the centre of the window

