

Technical specifications

Diesel Generator Set

QIS 175

Voltage: 400/230 V

Frequency: 50HZ



Genset Image for illustration purposes only

TECHNICAL INFORMATION

Standby Power (ESP)	kVA	173
	kW	139
Prime Power (PRP)	kVA	157
	kW	126
Mechanical structure	Soundproofed	
Engine	JOHN DEERE 6068HF120	
Alternator	MECC ALTE ECP34-3L/4A	
Control card	DEEP SEA 4520	
Measures (L x W x H)	mm	3,270 x 1,150 x 1,860
Empty weight	kg	2,110
Fuel tank	L	375
Acoustic pressure, LpA	dB(A) a 7	66
Acoustic power LwA	dB(A)	92

Voltages	Prime Power (PRP)		Standby Power (ESP)	
	(kVA)	(kW)	(kVA)	(kW)
380/220	155	124	170	136
400/230	157	126	173	139
415/240	157	126	173	139

Notes:

PRIME POWER: Electrical power data available at a variable load without limits of hours per year. An overload of 10 % is allowed for 1 hour of every 12. In accordance with ISO 8528/1 (2005) – PRP

STANDBY POWER: Electrical power data at variable load in an emergency in accordance with standard ISO 8528/1 (2005) – ESP. Overloads of emergency power are not allowed.

The standard reference conditions are: 25 °C, 100 kPa and 30% relative humidity. Gasoil density: 0.85 g/cm³. Gasoline density: 0.68 g/cm³.

■ INDEX

General description
Engine
Alternator
Bedplate
Soundproofed canopy
Electric Panel
ATS
Dimensions and Weight
Performance class
Regulation
Annex: Drawings

Grupos Electrógenos Europa, S.A. is a certified company with ISO 9001, ISO 14001, OHSAS 18001 and PECAL

We reserves the right to modify any characteristic of their equipment without prior warning.

Photographs representing the product range, while able to include options.

Weight and dimensions of a standard generator set.

Non-contractual document

Central Offices:

Polígono Industrial Pitarco II; Parcela 20

50450 Muel (Zaragoza) Spain

Tel.: +34 976 14 54 32

Fax: +34 976 14 54 31

info@gesan.com

After-sales Department:

Customer service: +34 976 14 54 33

Spare parts: +34 976 14 54 34

GENERAL DESCRIPTION

Specifically developed for the industrial applications, this stationary soundproof generator set is easy to use and straightforward to maintain. The available features & options are designed to fully meet the requirements of all industrial applications. The generator set will automatically start on mains failure and cool down and stop as soon as the mains come back. The generator set also controls the load transfer between mains (utility) and generator set. It can also be start-up by means of an external signal.

It's your solution for Predictable Power.

ENGINE

6068 series JOHN DEERE diesel 4 stroke engine, with turbo, with direct injection and mechanical regulation of the engine speed.

Engine brand	JOHN DEERE	Engine Capacity (c.c.)	6,800
Model	6068HF120	Bore (mm)	106
R.P.M.	1,500	Stroke (mm)	127
Fuel	Diesel	Compression ratio	17:1
No. of cylinders	6 L	Type of regulation	Mechanical

Cooling System

Cooling of the sleeves using cooling fluid comprised of water and glycol at 50% in a closed circuit driven by the engine pump.

The circuit is completed with a blower fan driven by the engine, radiator, expansion tank, cooling fluid purge system towards the outside of the bedplate and protections of all the running surfaces.

Cooling type	Water	Limit ambient temperature (°c)	48
Coolant capacity (l)	27		

A boiler system with heating element is available as an option. An adjustable thermostat is included to maintain the temperature at optimum range and facilitate the starting of the engine.

Coolant heater power (W)	1 x 1000W		
---------------------------------	-----------	--	--

Lubrication System

The lubrication system of this diesel engine comprises the oil pan, oil filter, oil switch and gear oil pump driven by the engine. All the components are original from the engine manufacturer.

It can be completed by an optional manual oil sump drain pump.

Oil capacity (l)	18.5		
-------------------------	------	--	--

Air intake system

Air intake system for combustion with filtering device and filter change indicator; originals from the engine manufacturer. Intake air cooling after the turbo by means of an air/air exchanger.

Intake air flow (m³/min)	9.8		
--	-----	--	--

Exhaust System

The exhaust system consists of pipes, bellow, interior and exterior aluminized steel exhaust silencer that is highly resistant to corrosion, rain cap and hot part protections.

T^a gas emission (°C)	600	Outlet diameter (")	4.5
Gas flow (m3/min)	21	Inlet diameter (")	3.5
Number of exhaust	1		

Start system

Start system that uses an electrical motor, battery and battery charge alternator that is driven by the engine itself. The start motor and the battery charge alternator are originals from the engine manufacturer.

Starter voltage system (V)	12	Battery type	1 x 12V 74Ah - 680A
-----------------------------------	----	---------------------	---------------------

Fuel supply system

The fuel system consists of a fuel tank, feed pump, water separator fuel filter including 30 microns filtering element, injection pump and injection nozzles.

The fuel tank is made from plastic to prevent rust and includes a filling connection with cap and key, a cleaning hatch and draining plug for easier maintenance. The fuel level is controlled thanks to a fuel level sensor with an analogue gauge mounted in the control cubicle.

Fuel tank capacity (L)	375		
-------------------------------	-----	--	--

Fuel consumption panel (range according to the standard configuration)

Load	Prime Power (PRP)		Standby Power (ESP)	
	(l/h)	Range (h)	(l/h)	Range (h)
25%	9.2	41	10	38
50%	18	21	19.3	19.4
75%	25	14.9	27	13.8
100%	32	11.8	35	10.8

ALTERNATOR

Brand	MECC ALTE	Voltage Stability	±1%
Model	ECP34-3L/4A	Performance at 75% p.f. 0.8 (%)	94
Alternator Power (kVA)	175 / Standby (SB27)	Performance at 100% p.f. 0.8 (%)	93
Number of wires	12	Direct subtransient reactance X''d (%)	6.4
IP Alternator	IP 23	Subtransient time constant, T''d (ms)	10
Excitation system	MAUX	Zero sequence reactance, Xo (%)	3.1
AVR model	DSR	Short-circuit ratio, Kcc	0.5

▪ BEDPLATE

The engine-alternator set is coupled to the bedplate by means of anti-vibration shock mounts that absorb almost all the vibrations.

The base frame is made of a phosphate, passivated steel profile with polyester dust paint that guarantees a resistance of up to 480 hours in a saline mist chamber in accordance with standard ASM B-117-09.

The base frame is able to hold 100% of the liquids of the genset, reducing any potential environmental impact. It has a drainage plug.

▪ SOUNDPROOFED CANOPY

Soundproof generator set by means of galvanized, phosphate steel, passivated and finish using polyester dust paint that guarantees a resistance of at least 720 hours in a saline mist chamber in accordance with standard ASM B-117-09.

The canopy includes an external access to the lifting beam and push to close latches with key. The lifting beam is available as an option.

It is lined inside with a noise-absorbing material of polyurethane foam with a 30 mm thick waterproof protector veil with a density of 25 kg/m³.

It also has an emergency shutdown pushbutton that is accessible from the outside.

▪ ELECTRIC PANEL

Easily accessed control cubicle integrated in the generator set with digital controller providing advanced engine monitoring and protection features. Performance and maintenance requirements can also be observed. The cubicle includes multi-poles thermal-magnetic protection circuit breaker against overloads and short-circuits.

Has a SCHNEIDER brand circuit breaker, manually actuated, with thermal-magnetic protection against overloads and short-circuits.

Circuit Breaker rated current (A)	250A 4P R	Battery charger	DSE 9150 - 12V 2A
--	-----------	------------------------	-------------------

Has a DEEP SEA battery charge maintainer, designed to be permanently connected to the battery and maintains it charged to its maximum capacity.

Has no moving parts. The charger switches to floating mode when the charge is complete

Control Card

DEEP SEA control plate, DSE 4520 with grid monitor that starts-up the generator set when it detects a failure in the electrical power supply from the grid and sends a signal to the switching panel to switch from the grid position to the group position. Once the power supply has been re-established, it sends an order to the switching panel to transfer the generator set power to the grid and shuts-down the generator set once it has cooled down. It also starts-up the generator set using an external signal.

Also, control plate DSE 4520 checks a large number of parameters of the generator set which allows it to display information, statuses and alarms. If required, it will shutdown the generator set: Due to high coolant fluid temperature, low oil pressure, low coolant fluid level, etc.

Includes a LCD screen with lighting, 2 navigation menu buttons, independent operational mode buttons, and alarms and status indicating LEDs.

Communications via USB, and Completely configurable using a PC in Windows environment and free Scada type software in real time.

Includes reading and displaying of parameters with RMS values, real time clock, events history log up to 15 events and programming of alarms, events, start-ups and shutdowns.

Operating modes: START-UP, SHUTDOWN, AUTO, MANUAL AND TEST.

Generator

- Generator voltage (L-N)
- Generator voltage (L-L)
- Generator frequency
- Generator current
- kW
- kVA
- kWh
- kVAh
- Power factor

Grid

- Grid voltage (L-N)
- Grid voltage (L-L)
- Grid frequency

Engine

- Turn speed
- Cooling fluid temperature
- Oil pressure
- Hour meter
- Battery voltage
- No. of start-ups
- Fuel level

Protections

- Start-up fault (generator set shutdown)
- High coolant temperature (alarm and generator set shutdown)
- Low oil pressure (alarm and generator set shutdown)
- Low fuel level (alarm)
- Low cooling fluid level (generator set shutdown)
- Overload (alarm and generator set shutdown)
- Battery voltage high (alarm)
- Battery voltage low (alarm)
- Battery charge alternator failure (alarm)
- Generator low frequency (alarm and shutdown)
- Generator high frequency (alarm and shutdown)
- Generator low voltage (alarm and shutdown)
- Generator high voltage (alarm and shutdown)
- External emergency shutdown (shutdown)
- Engine overspeed (shutdown)
- Maintenance interval (alarm)



■ ATS

Optional cabinet for switching between the grid and the generator set by means of a Socomec brand motorized switch with an integrated mechanical and electrical interlocking device.

Allows for the padlock locking function. Includes a Manual / Automatic mode selector and emergency manual control.

Safety switching for isolating the loads. High dynamic resistance against short-circuits.

Position indicator with fully visualized cut-off. Stable positions not affected by changes in voltage and mechanical vibrations. External electrical control of the positions and test sequences.

High number of operations. IP54 protection. Connections: Lower/lower.

ATS	4P 330A 160-333V L-N CCM
------------	--------------------------

■ DIMENSIONS AND WEIGHT

Length, L (mm)	3,270
Width, A (mm)	1,150
Height, H (mm)	1,860
Weight (kg)	2,110

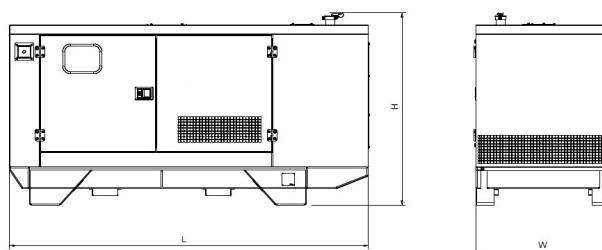

■ PERFORMANCE CLASS

Execution class in accordance with ISO 8528/5 (2005) taking into account the behaviour of the generator set in a permanent mode of operation with different load levels, as well as in a temporary mode of operation due to shocks in the load.

Performance class	G2
--------------------------	----

■ REGULATION

The generator set has a CE Marking that includes the following directives:

- 2006/42/EC Machine Safety.
- 2014/35/EU Low Voltage.
- 2014/30/EU Electromagnetic compatibility.
- 2005/88/EC Noise emissions of machines outdoors in soundproof generator sets.

Regulation (EU) 2016/1628 Gases and contaminating particles emissions only for groups within its scope of application.

Applicable international regulations:

- ISO 8528
- ISO 3046
- BS 5000
- IEC 60034

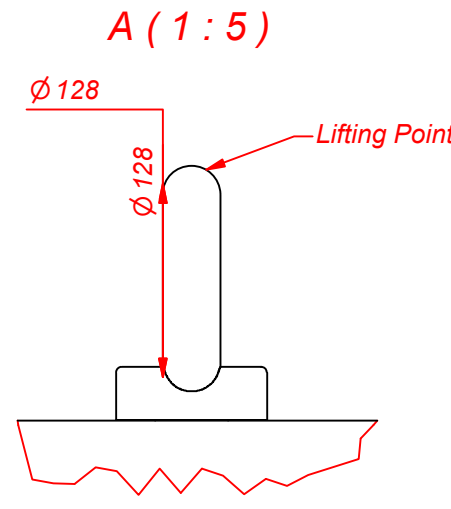
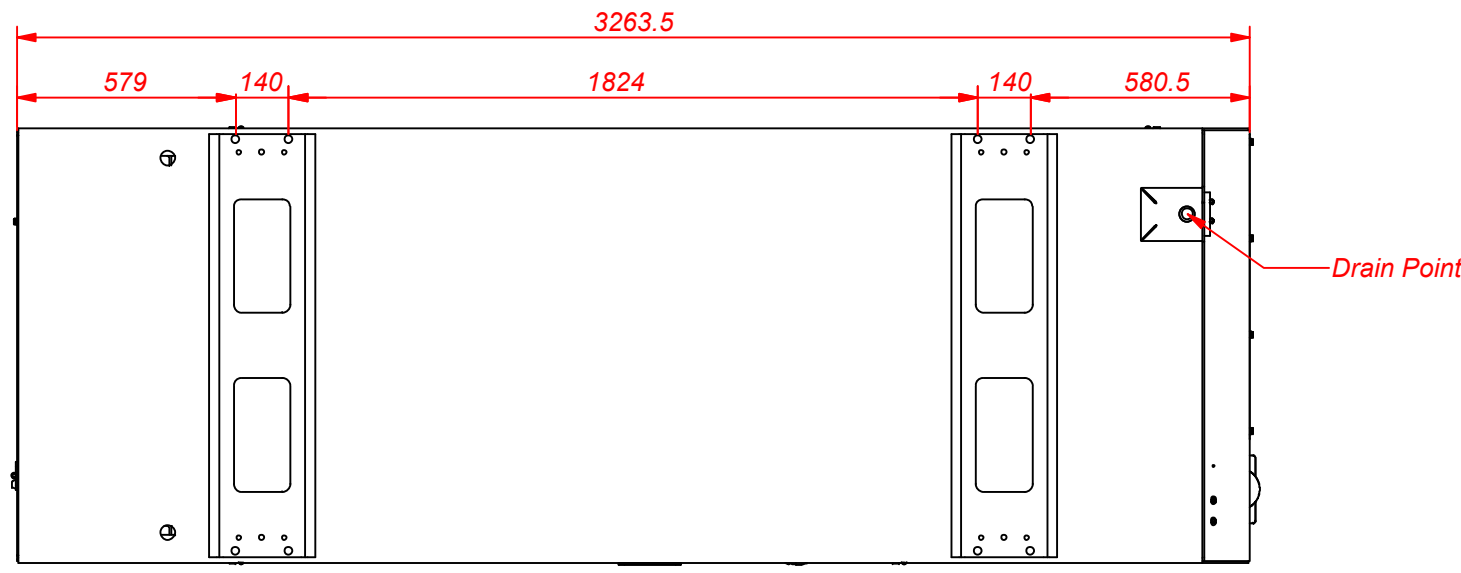

BASIC UNIT								
TYPE	WET MASS Kg	Xz mm	Yz mm	Zz mm	NET MASS Kg	Xz mm	Yz mm	Zz mm
Q/S/QES/CPSG 6068TF220	2425	1400	575	675	2100	1400	575	675
Q/S/QES/CPSG 6068HF120	2535	1400	575	675	2210	1400	575	675
Q/S/QES/CPSG 6068HFG20	TBD	1400	575	675	TBD	1400	575	675

WET MASS = Wet engine and radiator (oil, coolant) and full tank.
NET MASS = Dry engine (without coolant and oil) and empty tank.

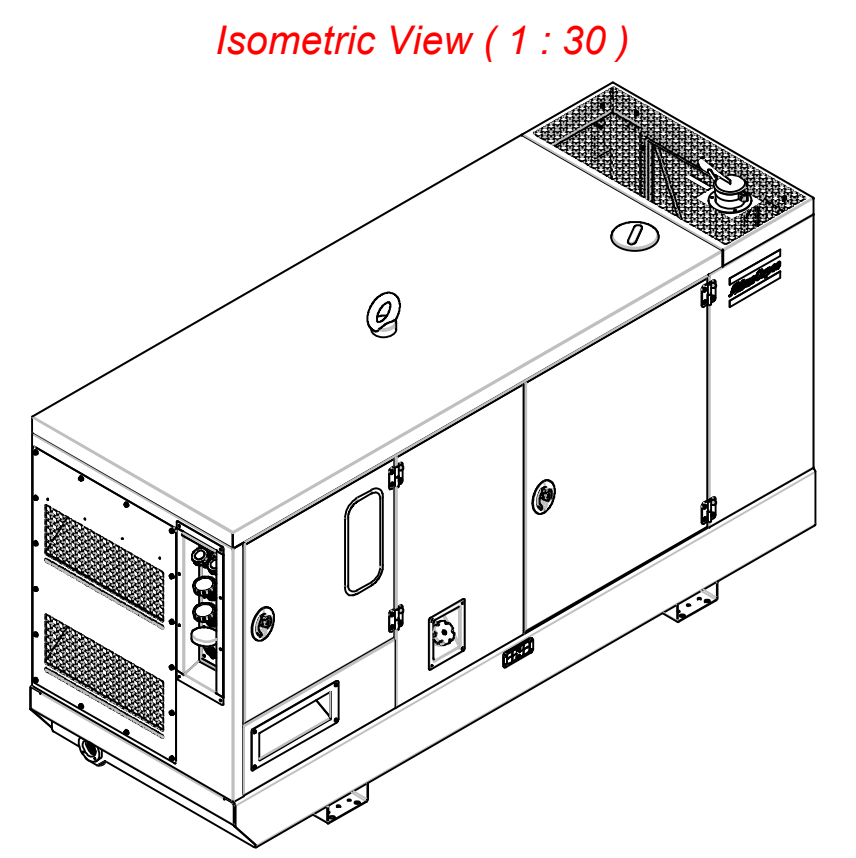
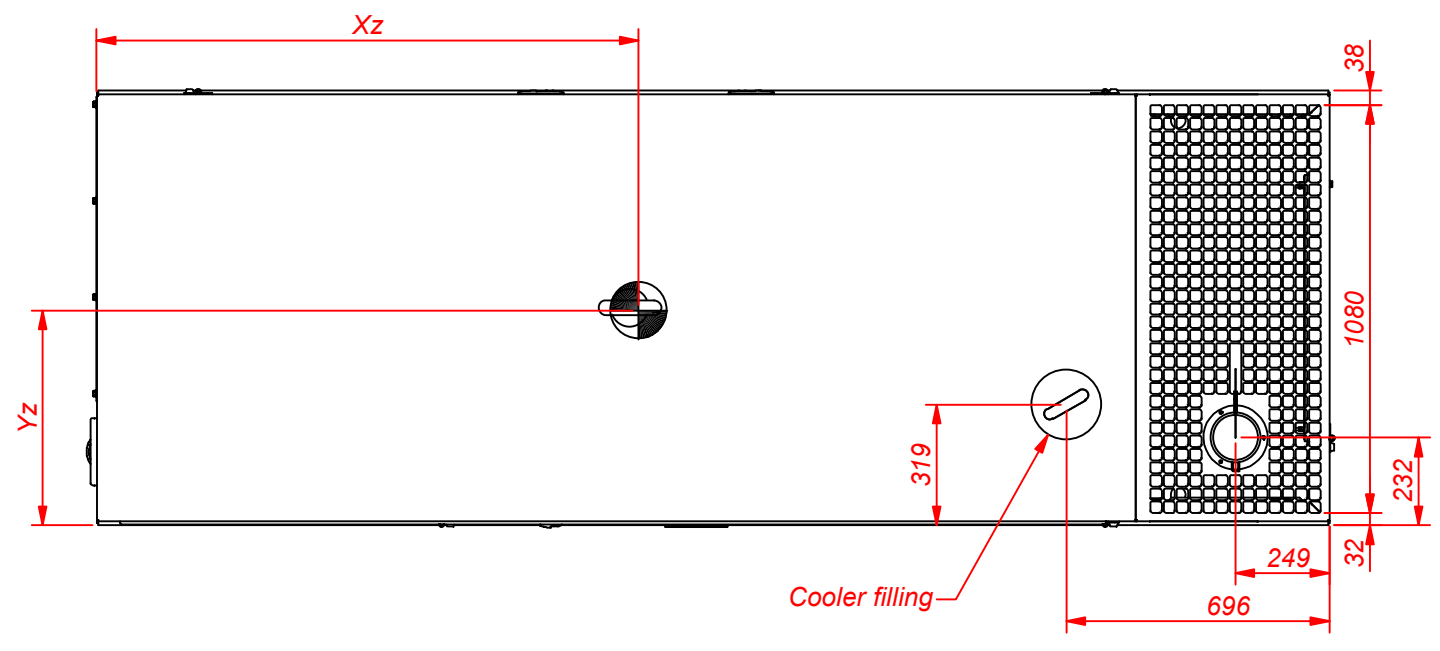
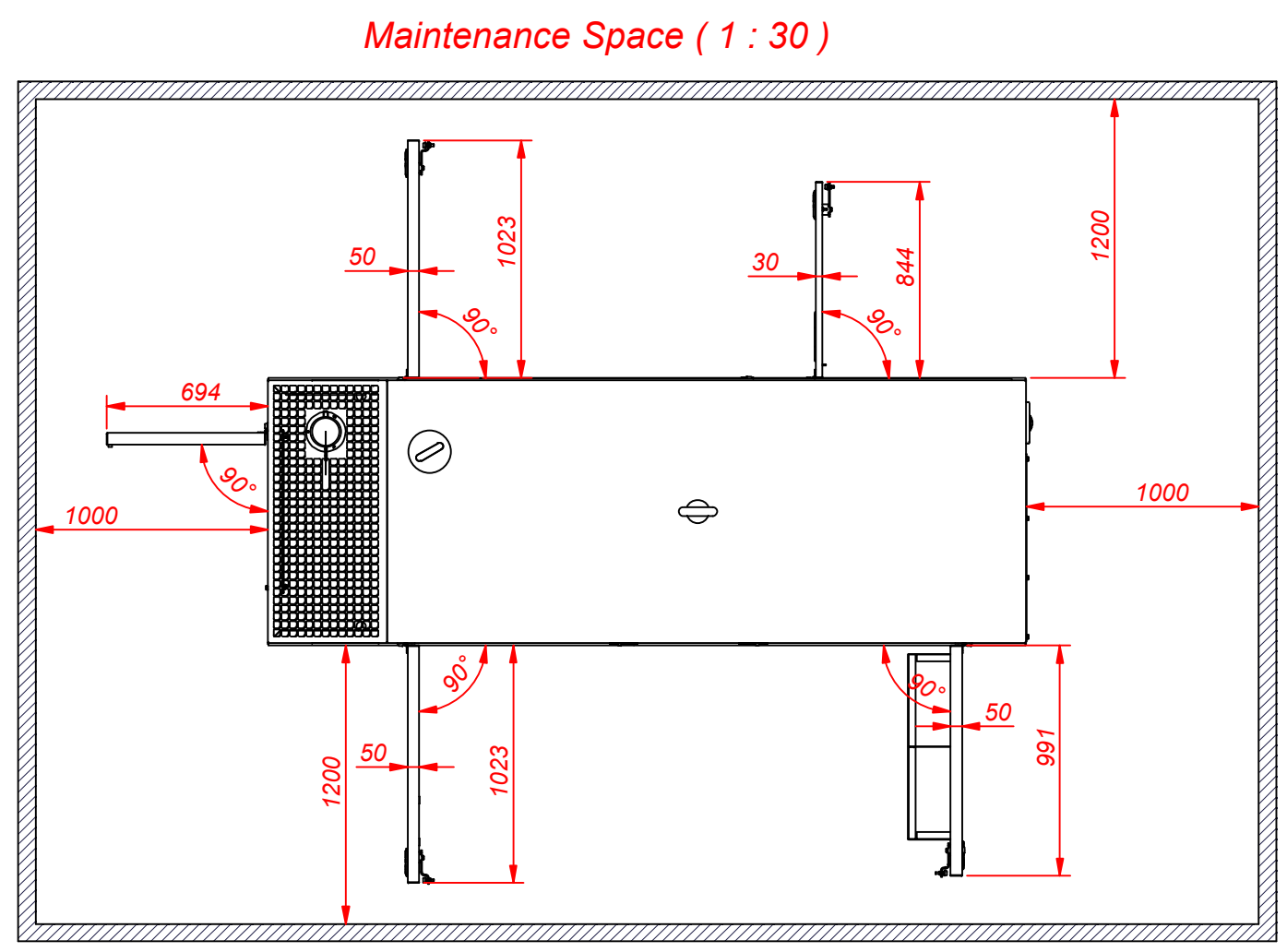
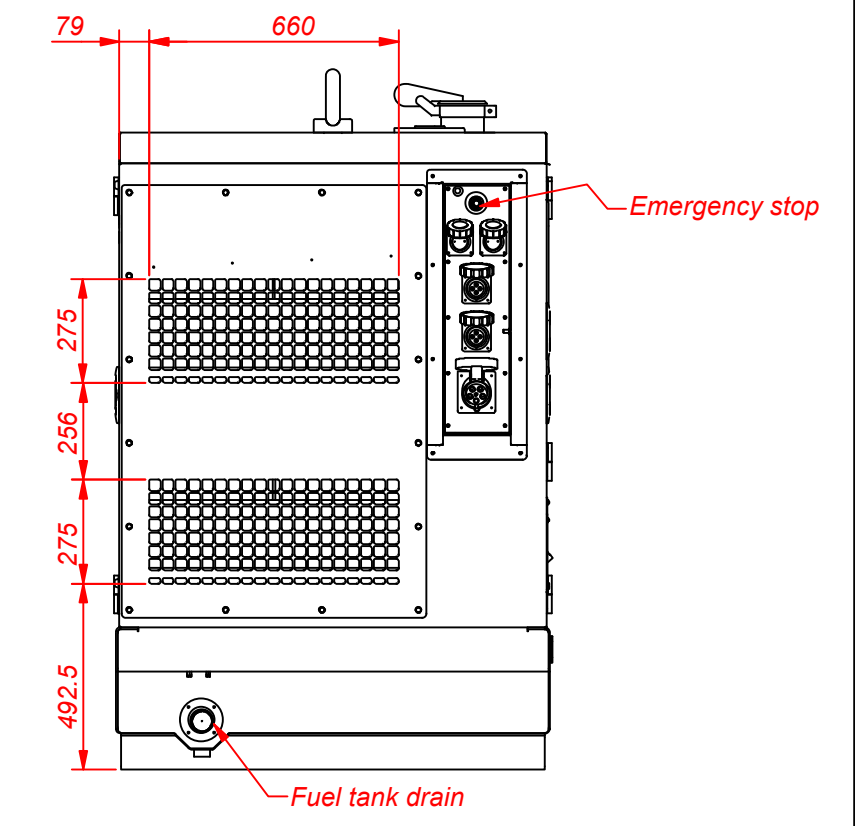
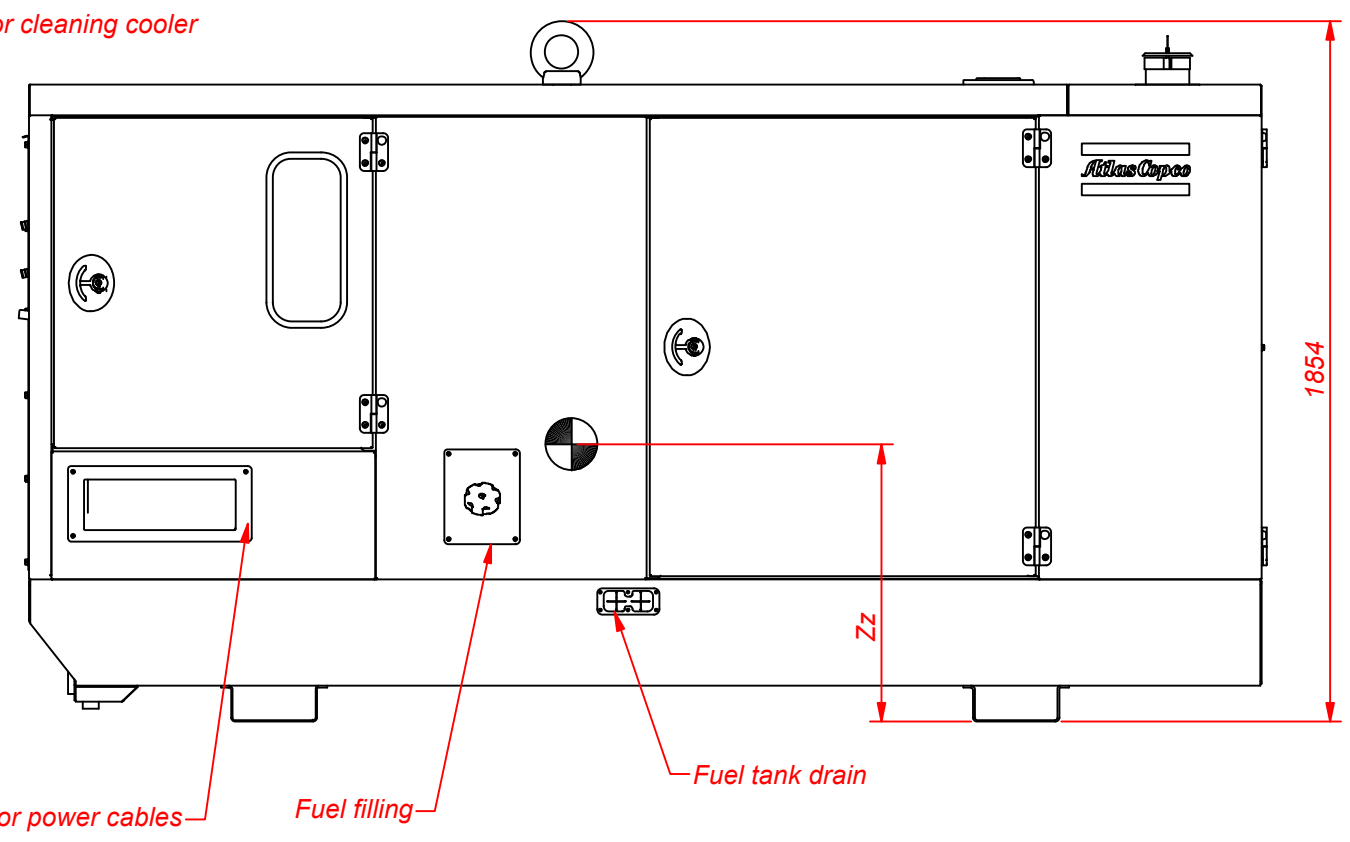
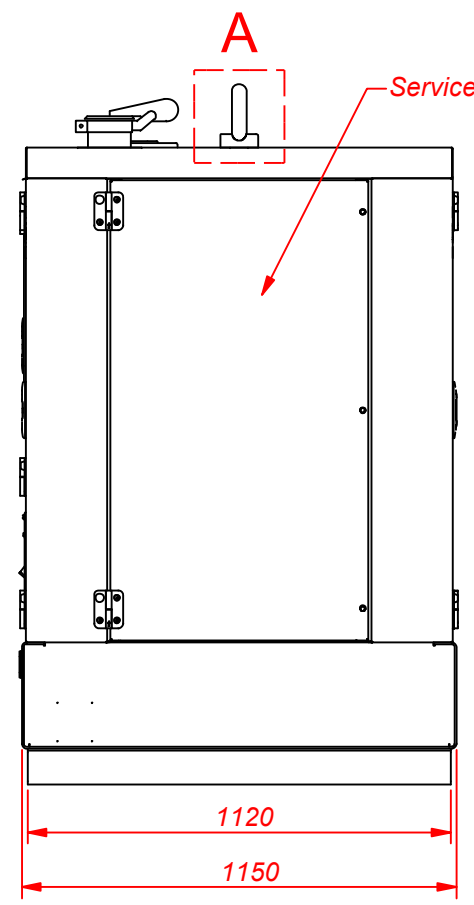
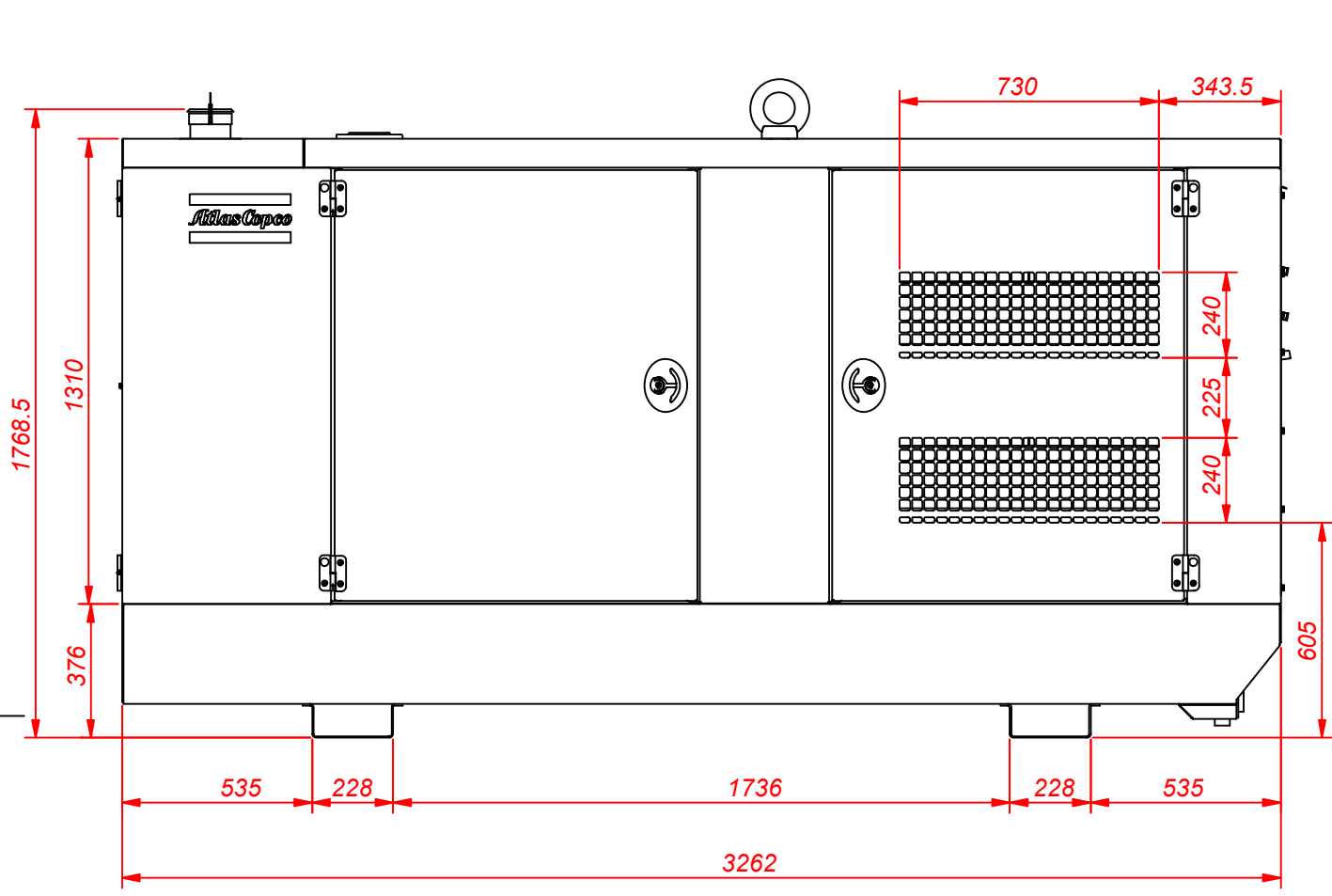

CONFIDENTIAL: This document is our property and shall not without our permission be altered, copied, used for manufacturing or communicated to any other person or company.

Ed	Position	Modified from	Date	Intr./Appd.
00				

1636011127	00
Parent 3D model	3D Model Edition

Tolerances, if not indicated, according to:		General tolerances					
		1350K - mK					
Name		DIMENSION DRWG		QIS/CPSG; CD		Confidentiality Class acc. to 1102 K	
Material						Confidential	
Treatment						Thickness: INV	
Scale		Family		A2 Compare		Drawing owner	
Drawn by estfh		Blank nr.		Replaces		ESF	
Version Drwg 00		Blank wt. Kg		Fini wt. Kg		Designation	
Des checked.		Prod checked.		Approved.		Date	
Approved				22/06/2016		1636011127	
						Sheet 1 / 8	

SKID option

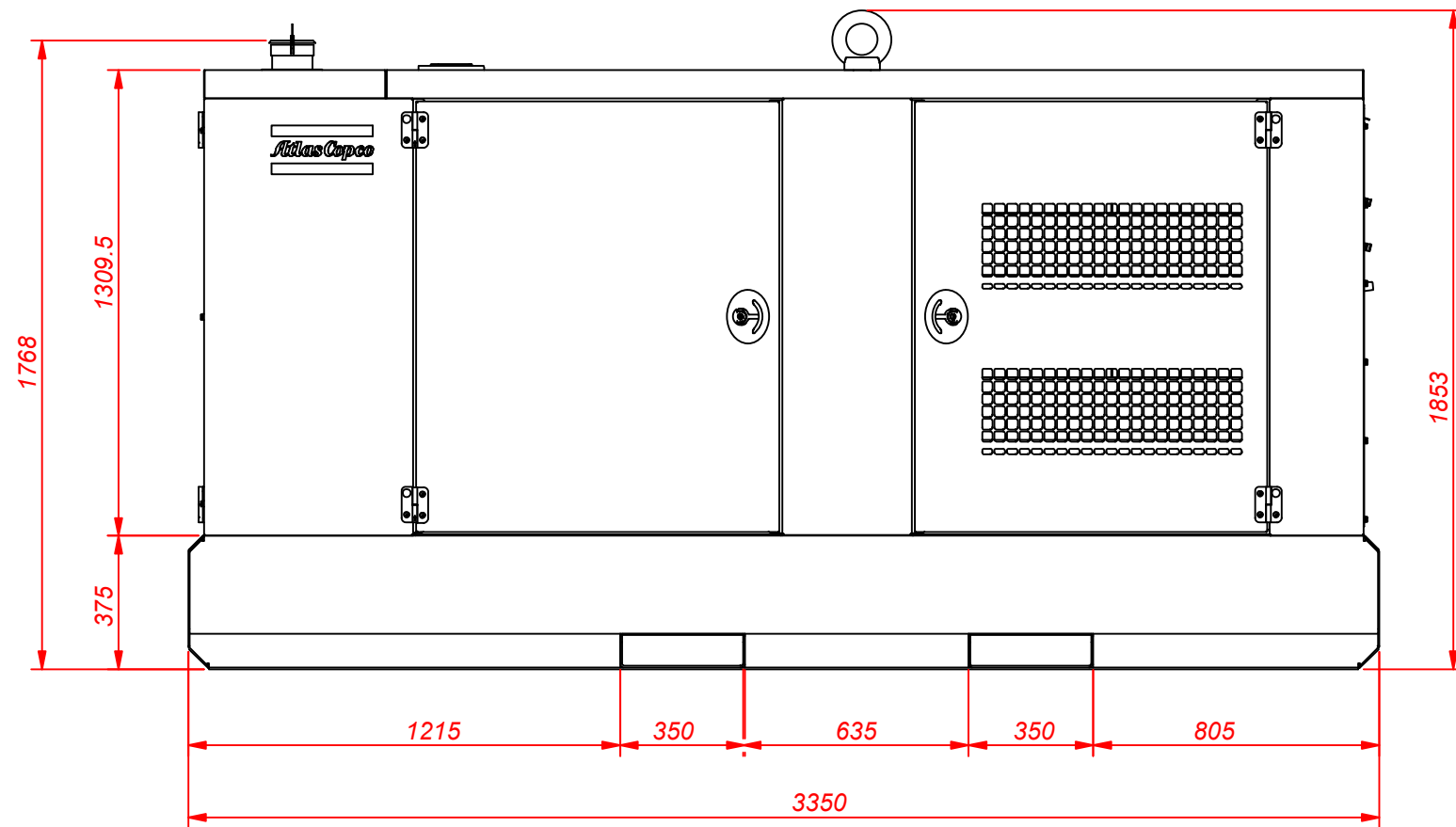
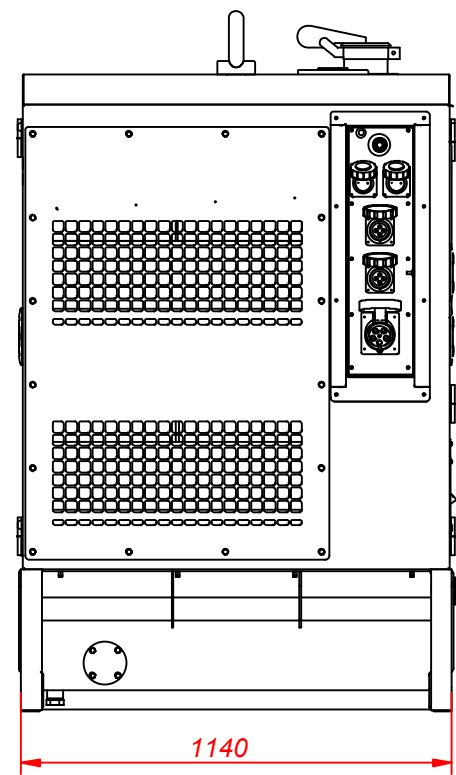
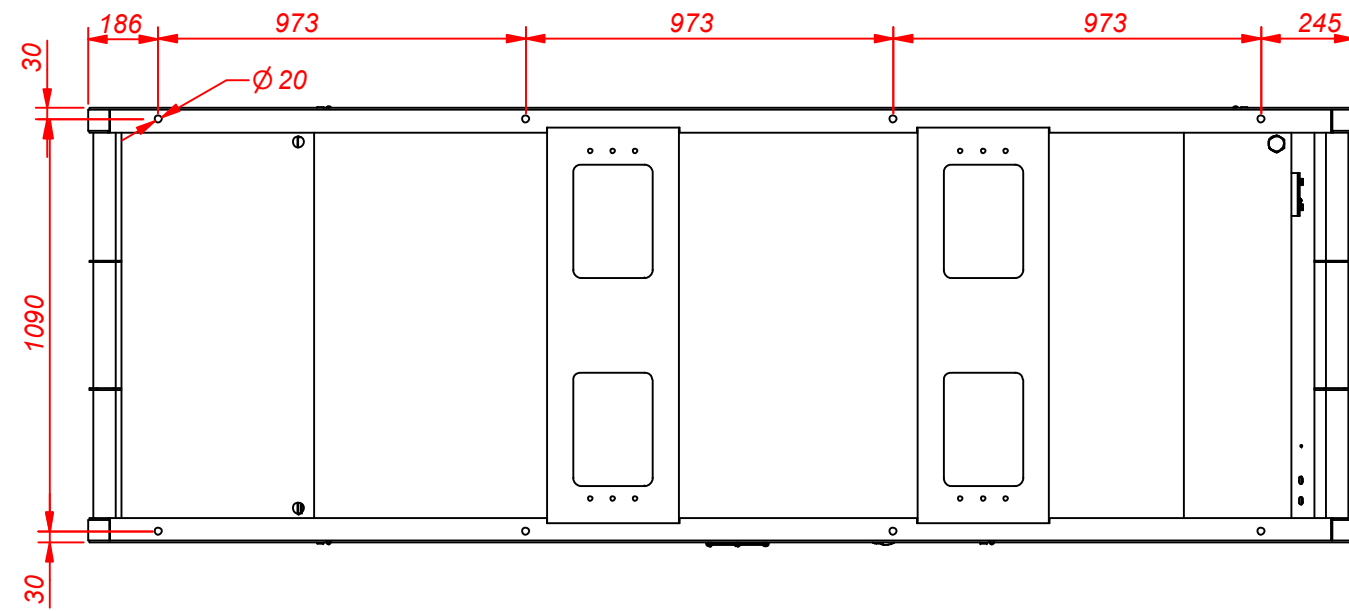

24H SKID option

TYPE	WET MASS Kg	BASIC UNIT			NET MASS Kg	Xz mm	Yz mm	Zz mm
		Xz mm	Yz mm	Zz mm				
QIS/QES/CPSG 6068TF220	3157	1400	575	675	2342	1400	575	675
QIS/QES/CPSG 6068HF120	3267	1400	575	675	2452	1400	575	675
QIS/QES/CPSG 6068HFG20	TBD	1400	575	675	TBD	1400	575	675

WET MASS = Wet engine and radiator (oil, coolant) and full tank.
NET MASS = Dry engine (without coolant and oil) and empty tank.

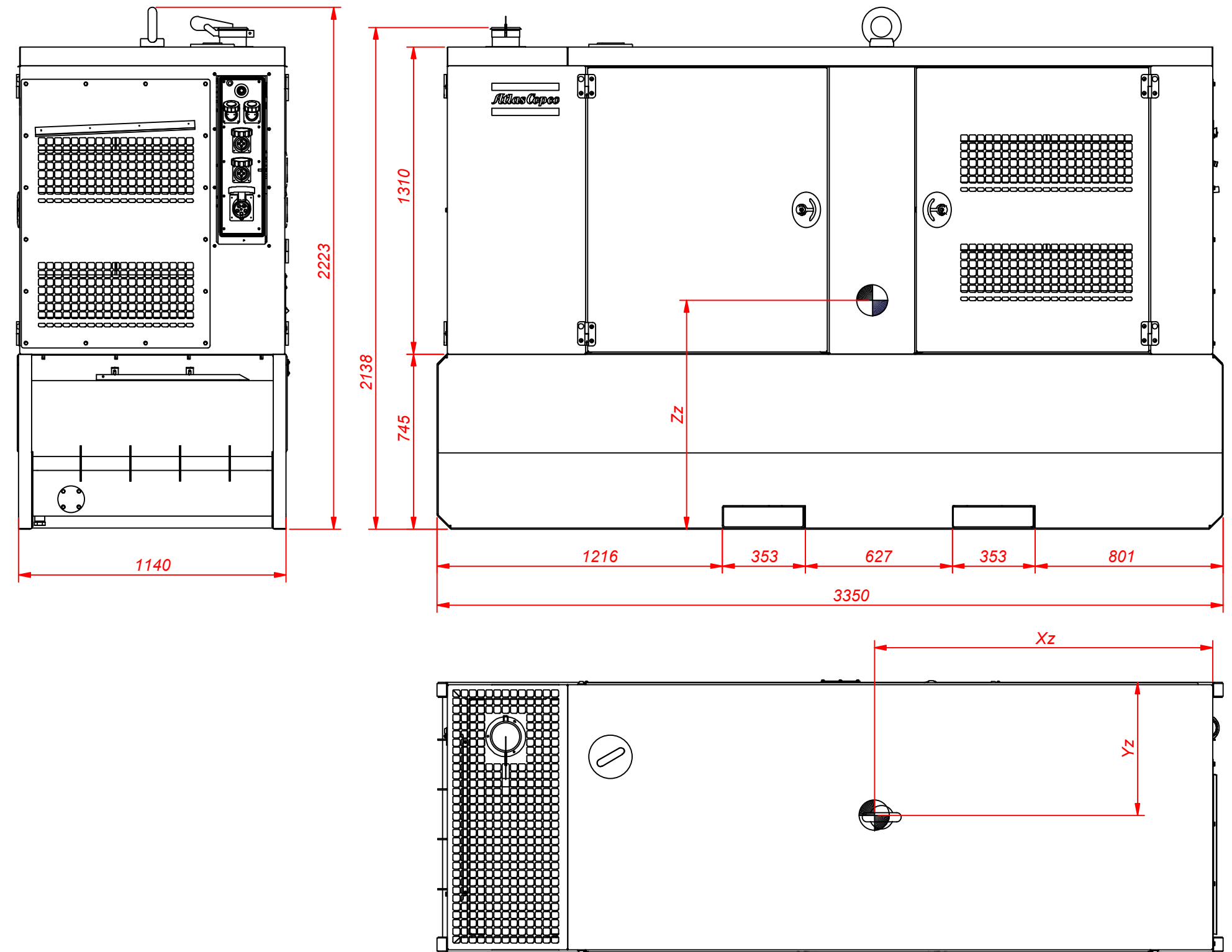

CONFIDENTIAL: This document is our property and shall not without our permission be altered, copied, used for manufacturing or communicated to any other person or company.

Ed	Position	Modified from	Date	Intr./Appd.
00				

Rest of dimensions are equal to standard unit

1636011127	00
Parent 3D model	3D Model Edition

Tolerances, if not indicated, according to:		General tolerances		1350K - mK	
Name				DIMENSION DRWG	
Material				QIS/CPSG; CD	
Treatment				Thickness: INV	
Scale		Family		A2 Compare	
Drawn by estfh		Blank nr.		Replaces	
Version Drwg 00		Blank wt. Kg		Finl wt. Kg	
Des checked.		Prod checked.		Approved.	
STATUS		Date		22/06/2016	
Designation				1636011127	
Drawing owner				ESF	
Sheet				2 / 8	

6068TF220

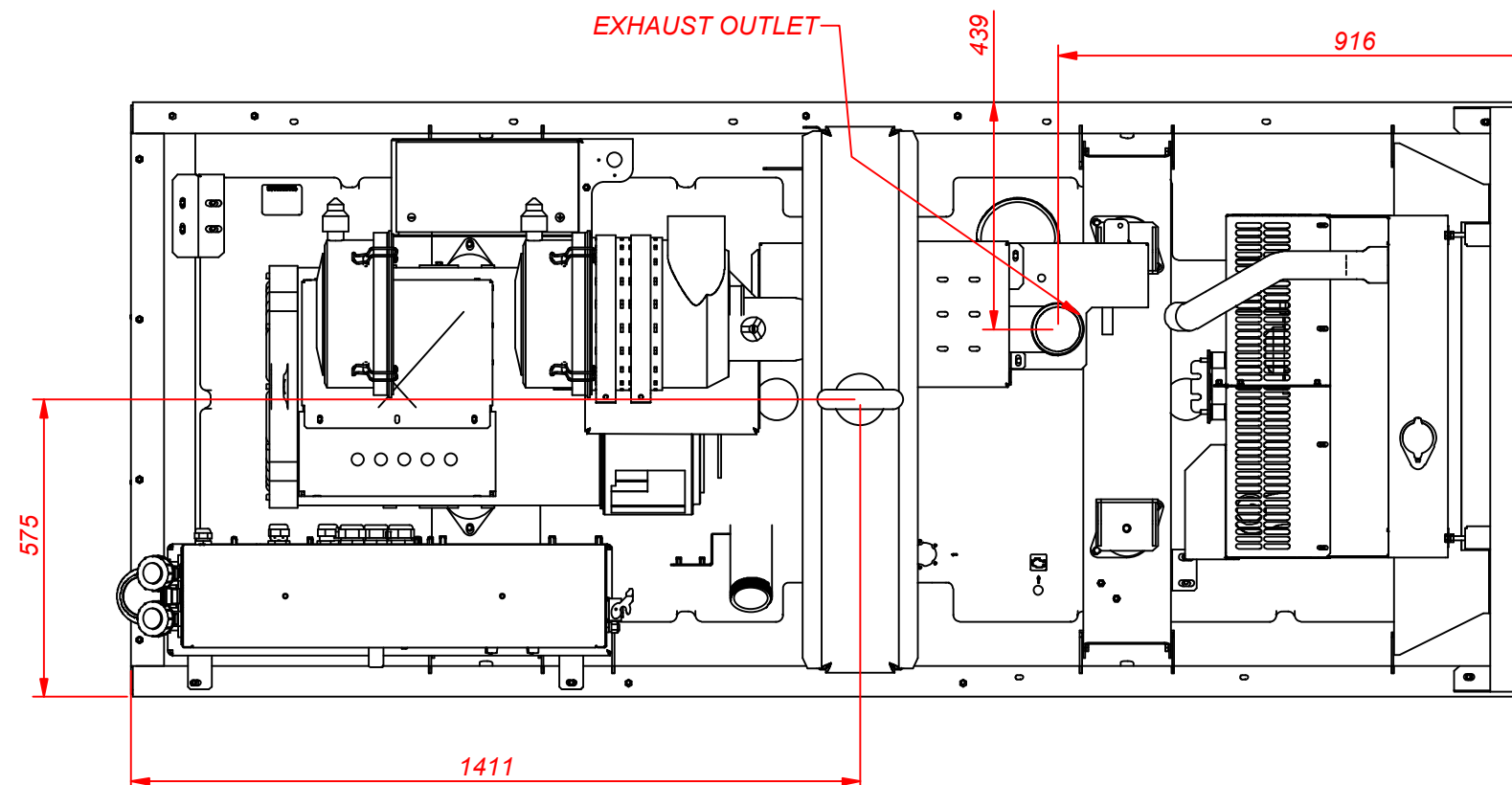
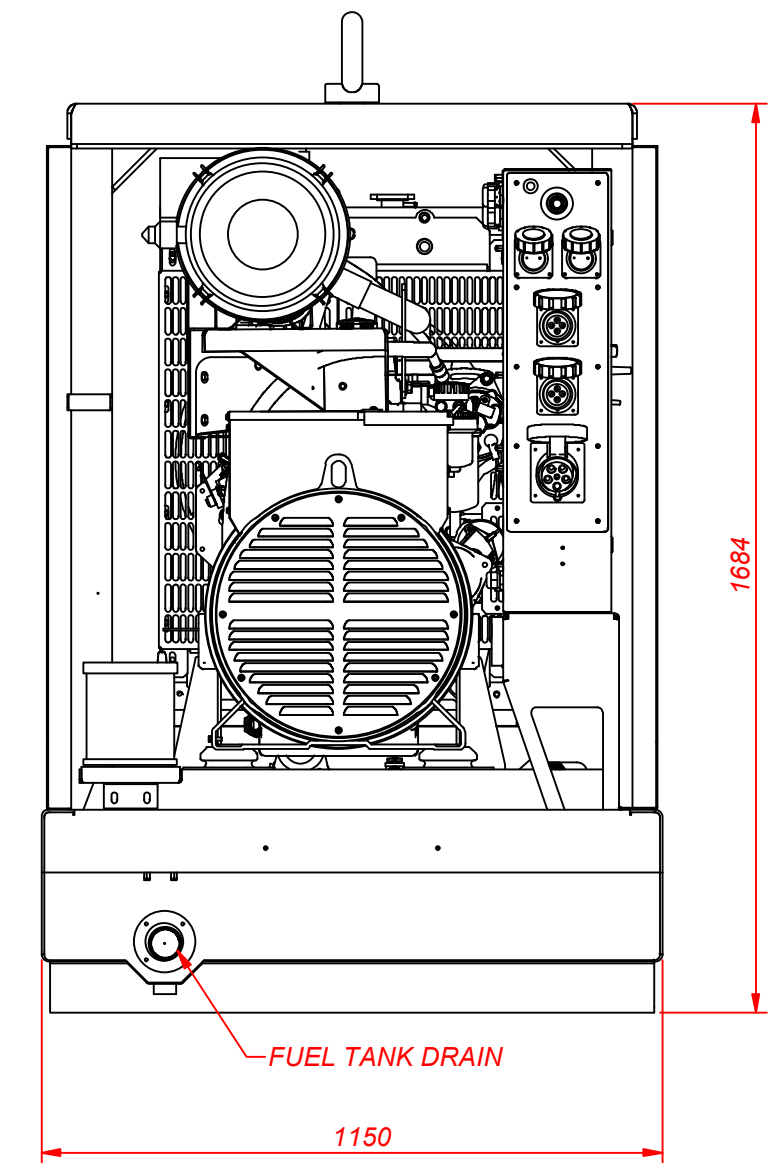
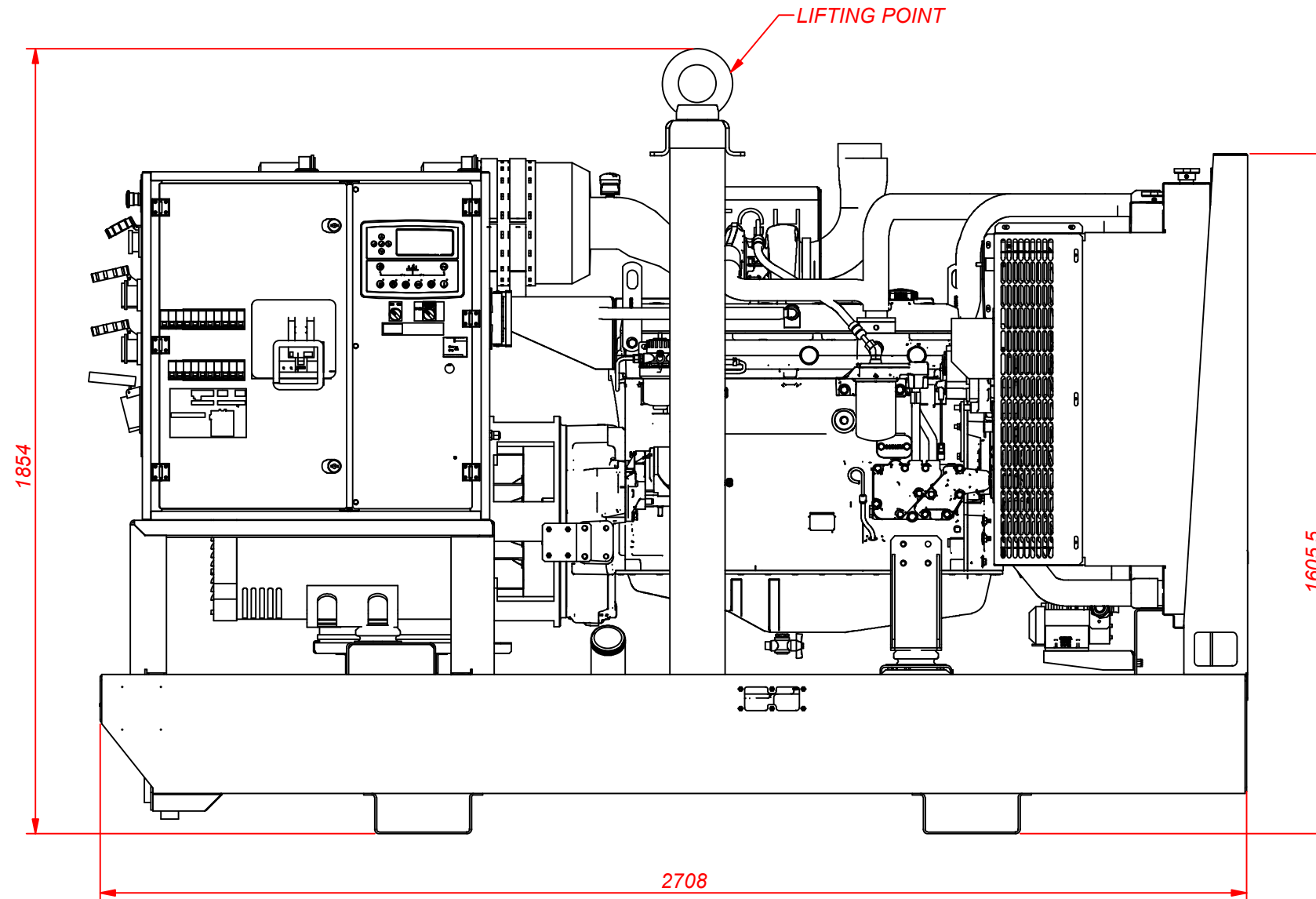
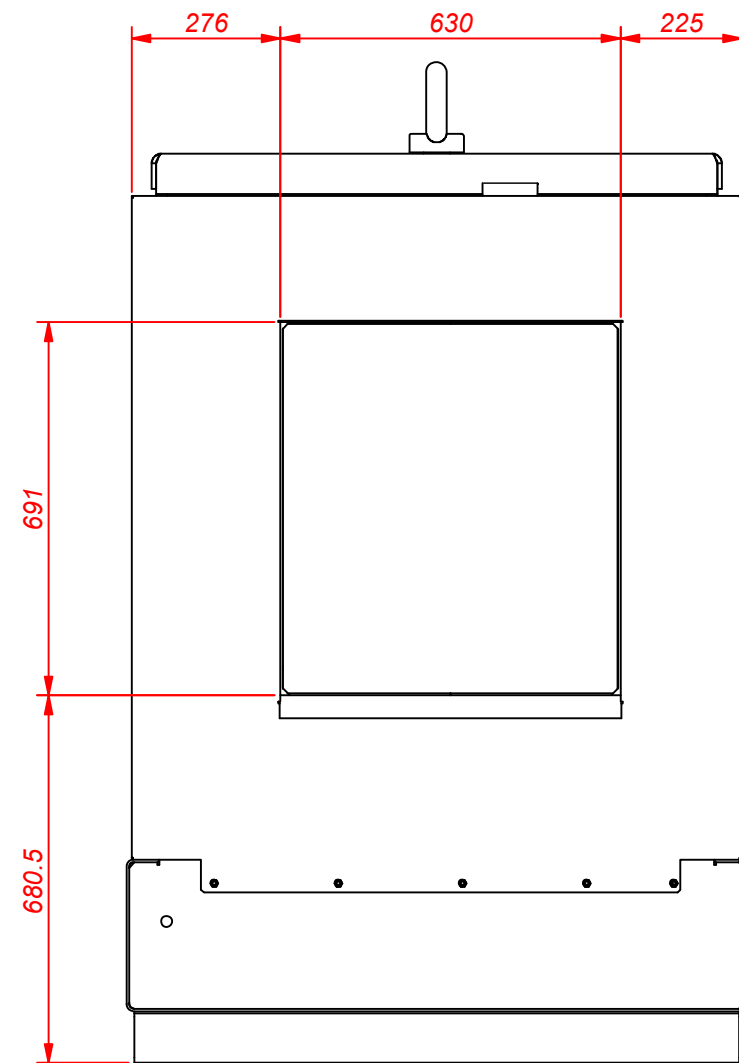
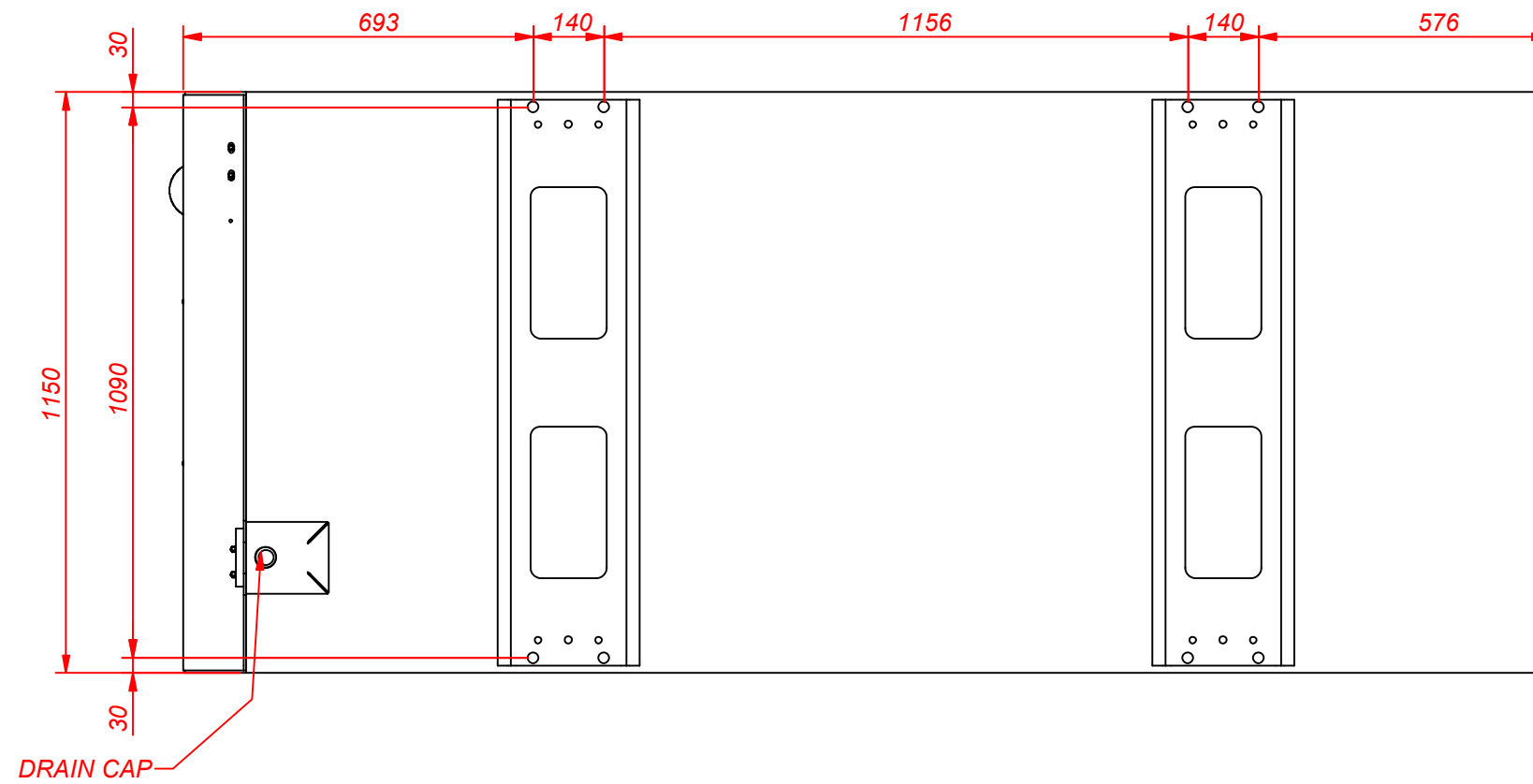

Tolerances, if not indicated, according to:									
Name		DIMENSION DRWG			QIS/CPSG; CD			Confidentiality Class acc. to 1102 K	
Material					Confidential				
Treatment					Thickness: INV			Drawing owner	
		Scale		Family		A2 Compare		Drawing owner	
Drawn by esfh		Blank nr.		Replaces		ESF			
Version Drwg		Blank wt.		Fini wt.		Designation		Sheet 3 / 8	
00		Kg		Kg		1636011127			
STATUS		Des checked.		Prod checked.		Approved.		Date 22/06/2016	
Approved									

CONFIDENTIAL: This document is our property and shall not without our permission be altered, copied, used for manufacturing or communicated to any other person or company.

00				
Ed	Position	Modified from	Date	Intr./Appd.

1636011127	00
Parent 3D model	3D Model Edition

6068HF120

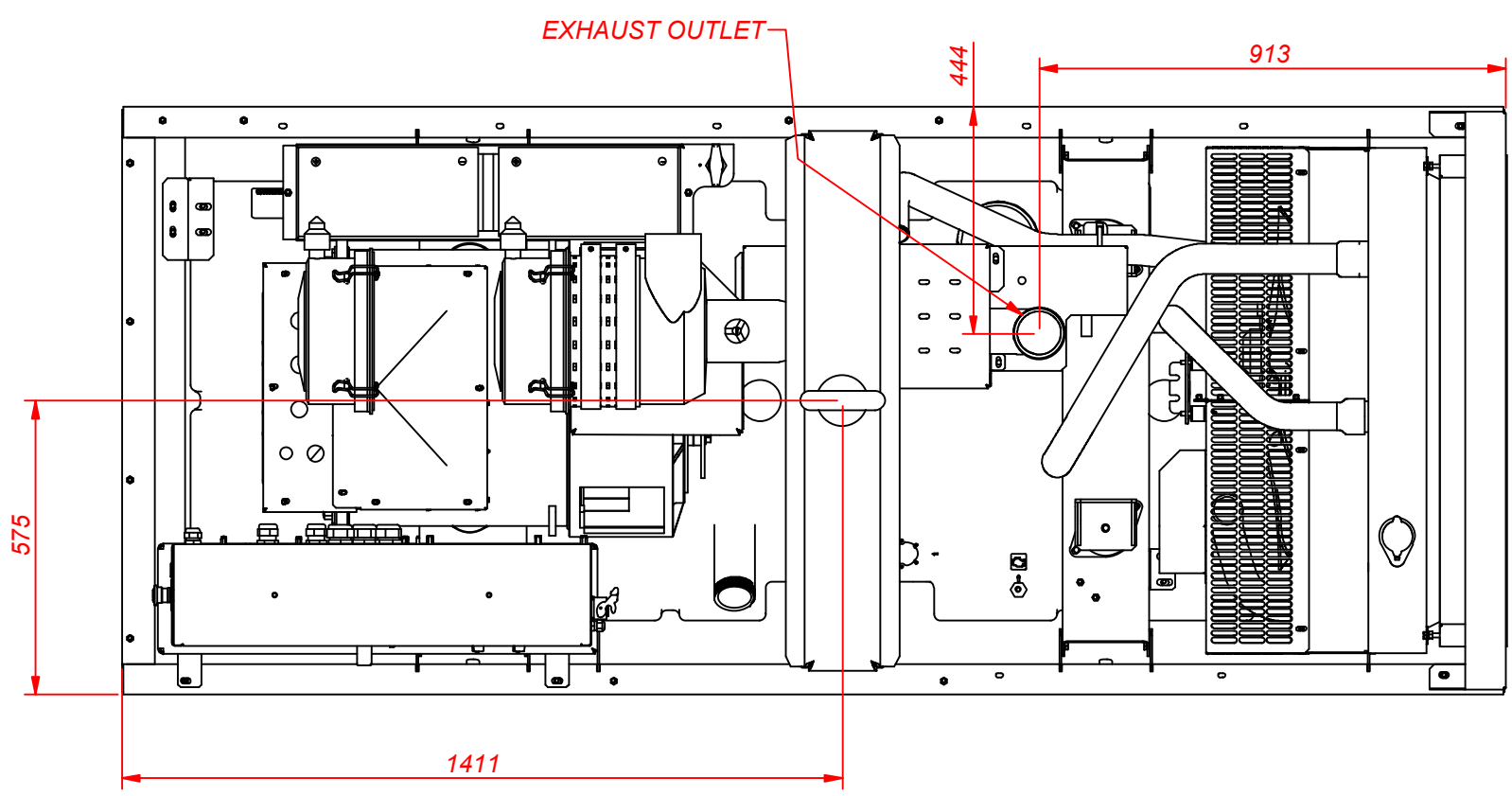
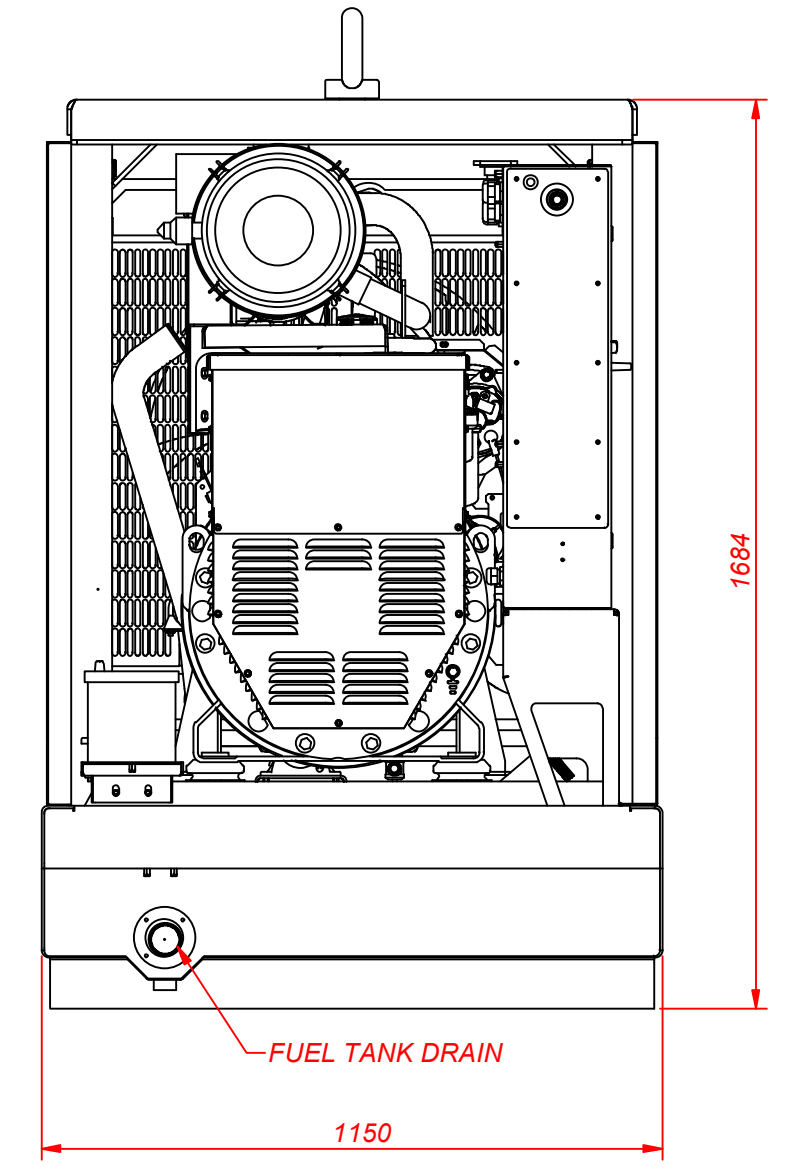
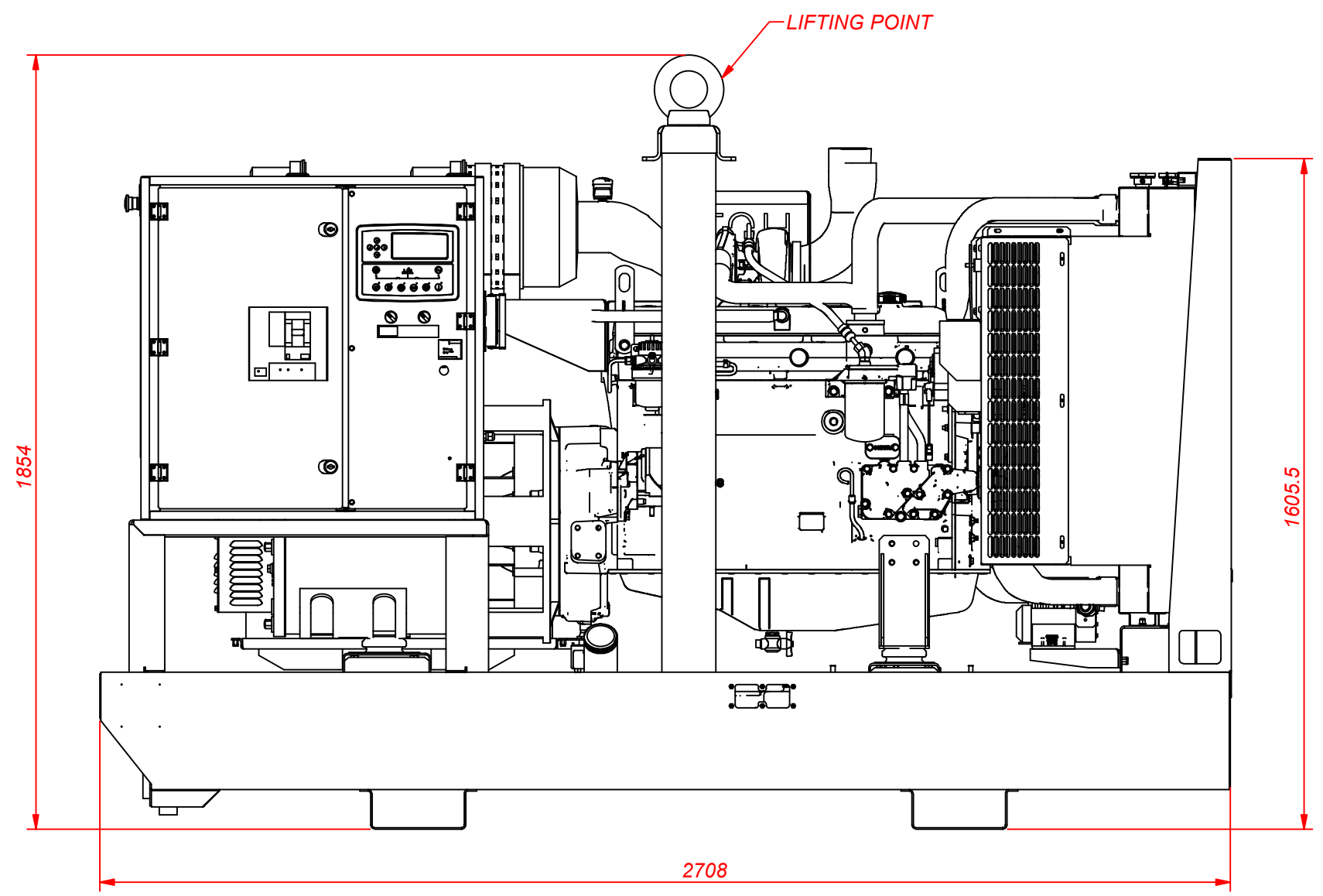
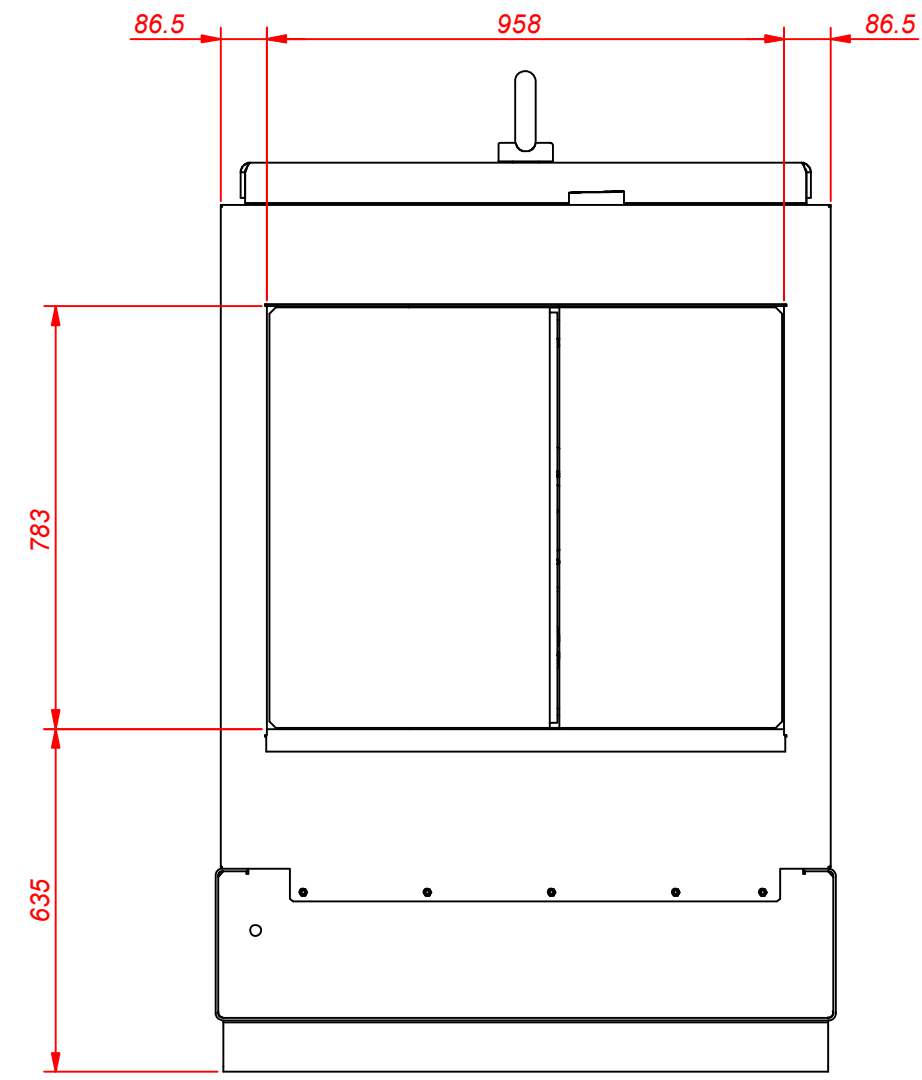
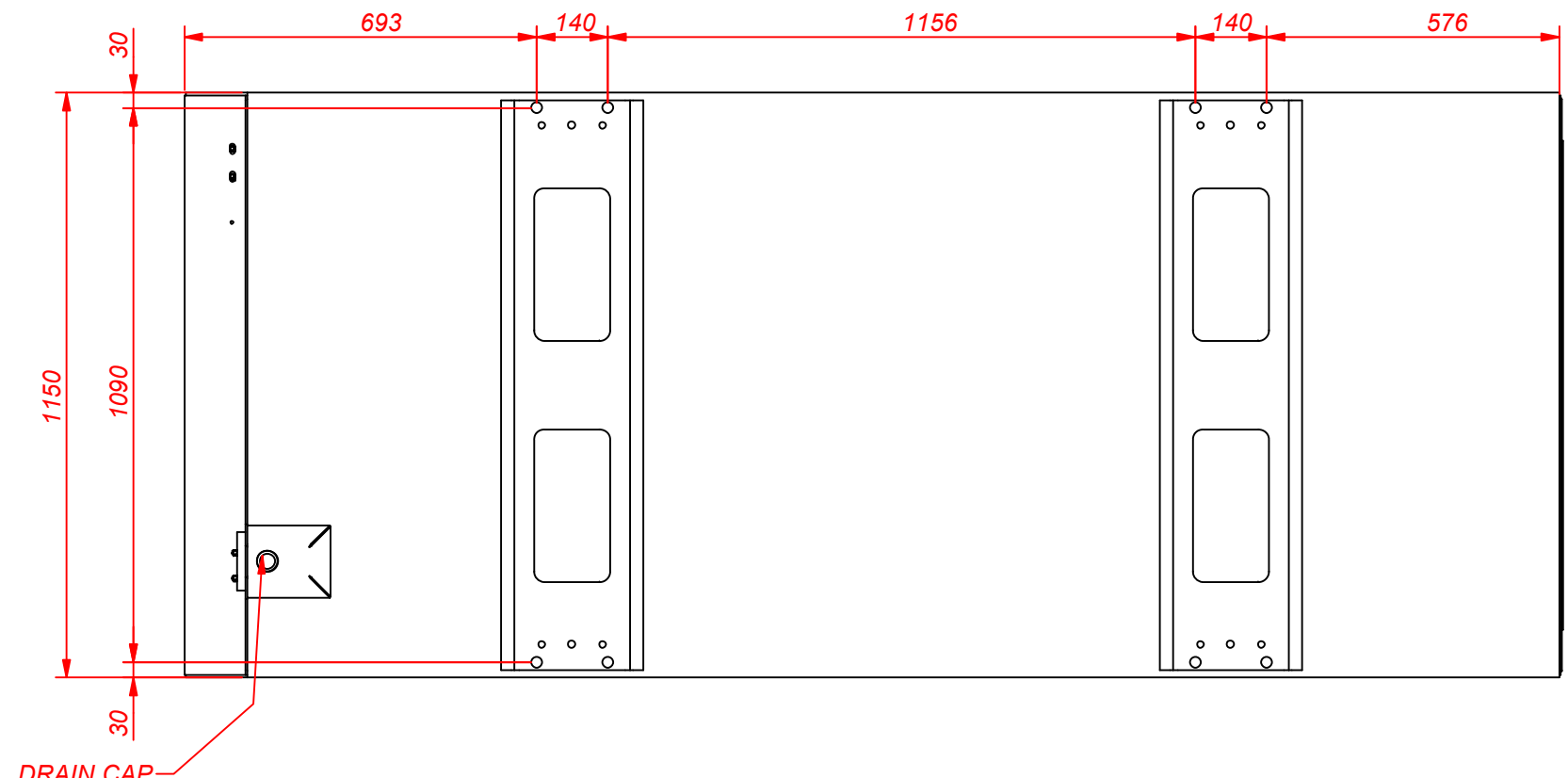

Tolerances, if not indicated, according to:

Name	DIMENSION DRWG		QIS/CPSG; CD		Confidentiality Class acc. to 1102 K
Material					Confidential
Treatment					Thickness: INV
Scale	Family	A2 Compare		Drawing owner	
Drawn by esfh	Blank nr.		Replaces		ESF
Version Drwg 00	Blank wt. Kg	Fin. wt. Kg	Designation		Sheet 4 / 8
STATUS	Des checked.	Prod checked.	Approved.	Date 22/06/2016	1636011127

CONFIDENTIAL: This document is our property and shall not without our permission be altered, copied, used for manufacturing or communicated to any other person or company.

00				
Ed	Position	Modified from	Date	Intr./Appd.

1636011127	00
Parent 3D model	3D Model Edition

6068HFG20

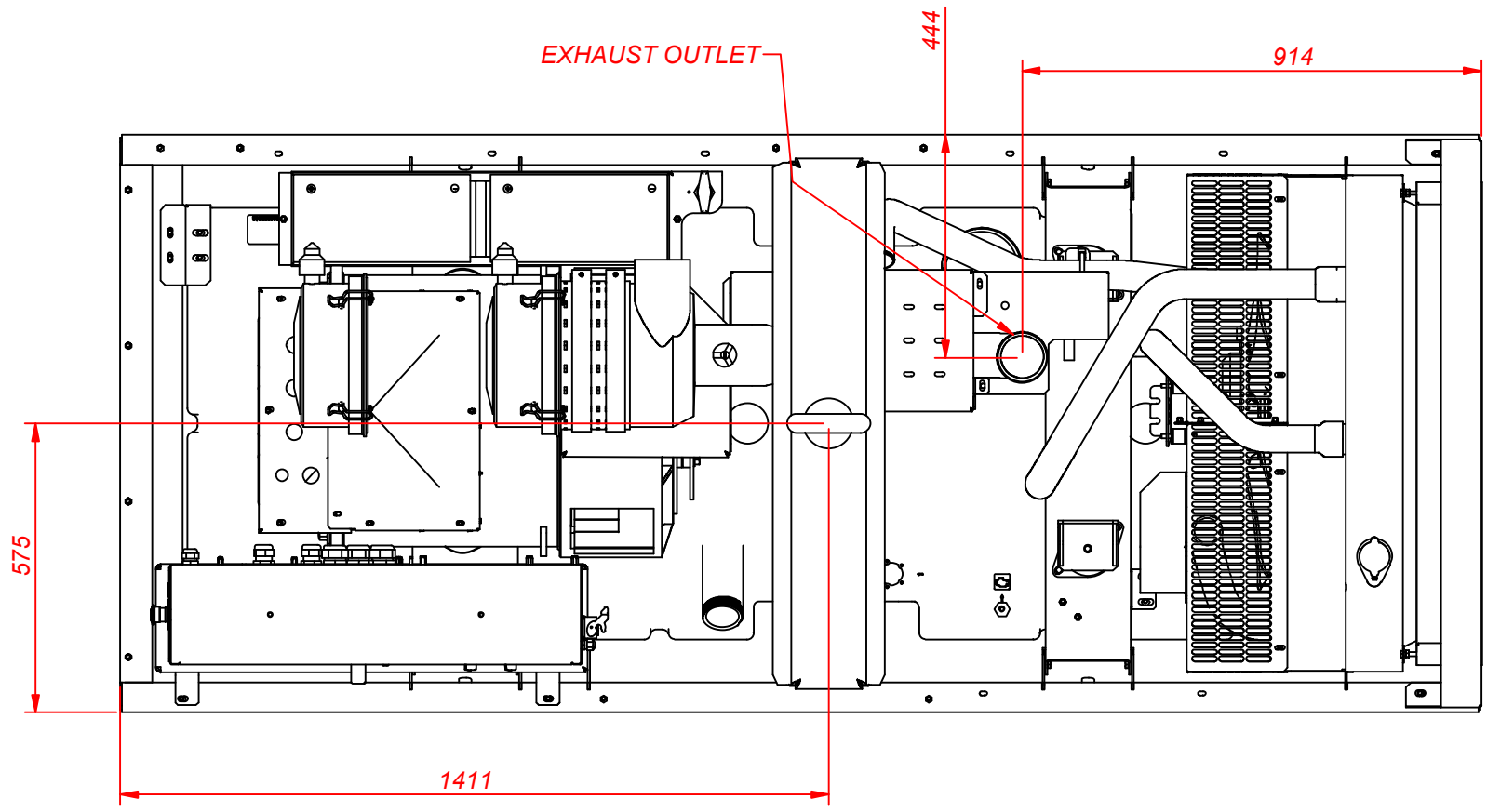
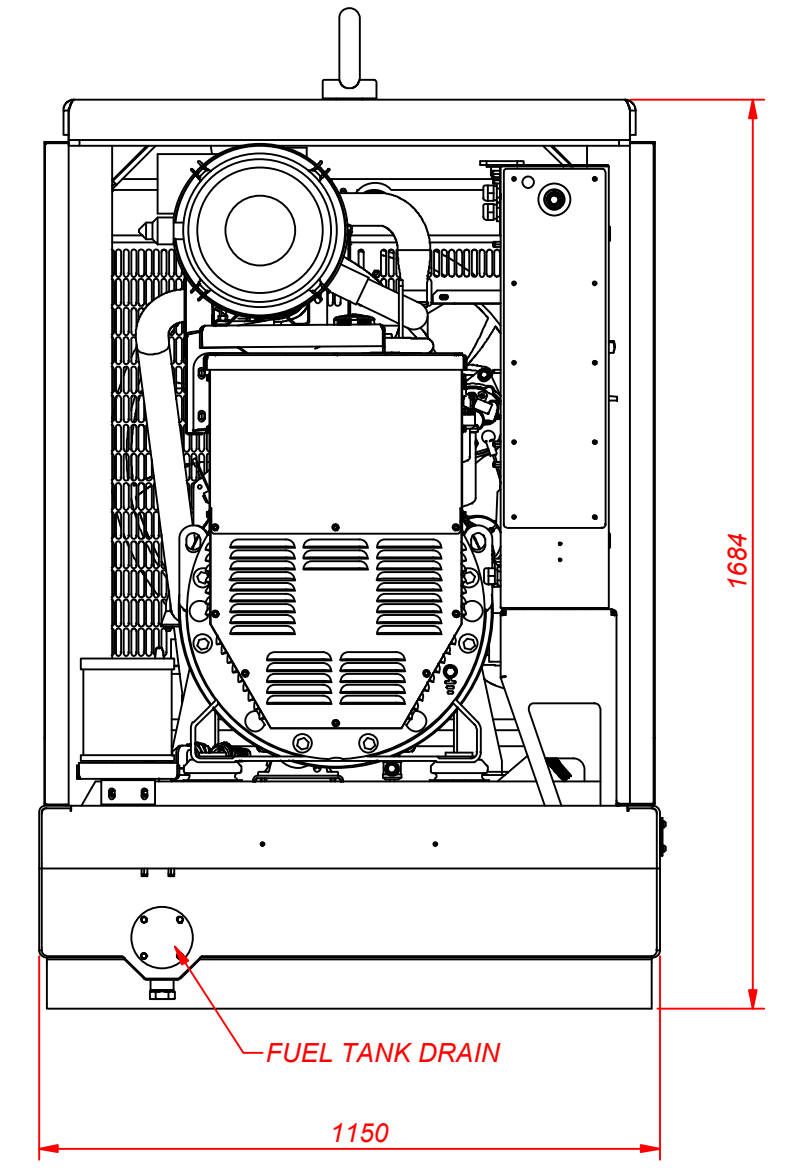
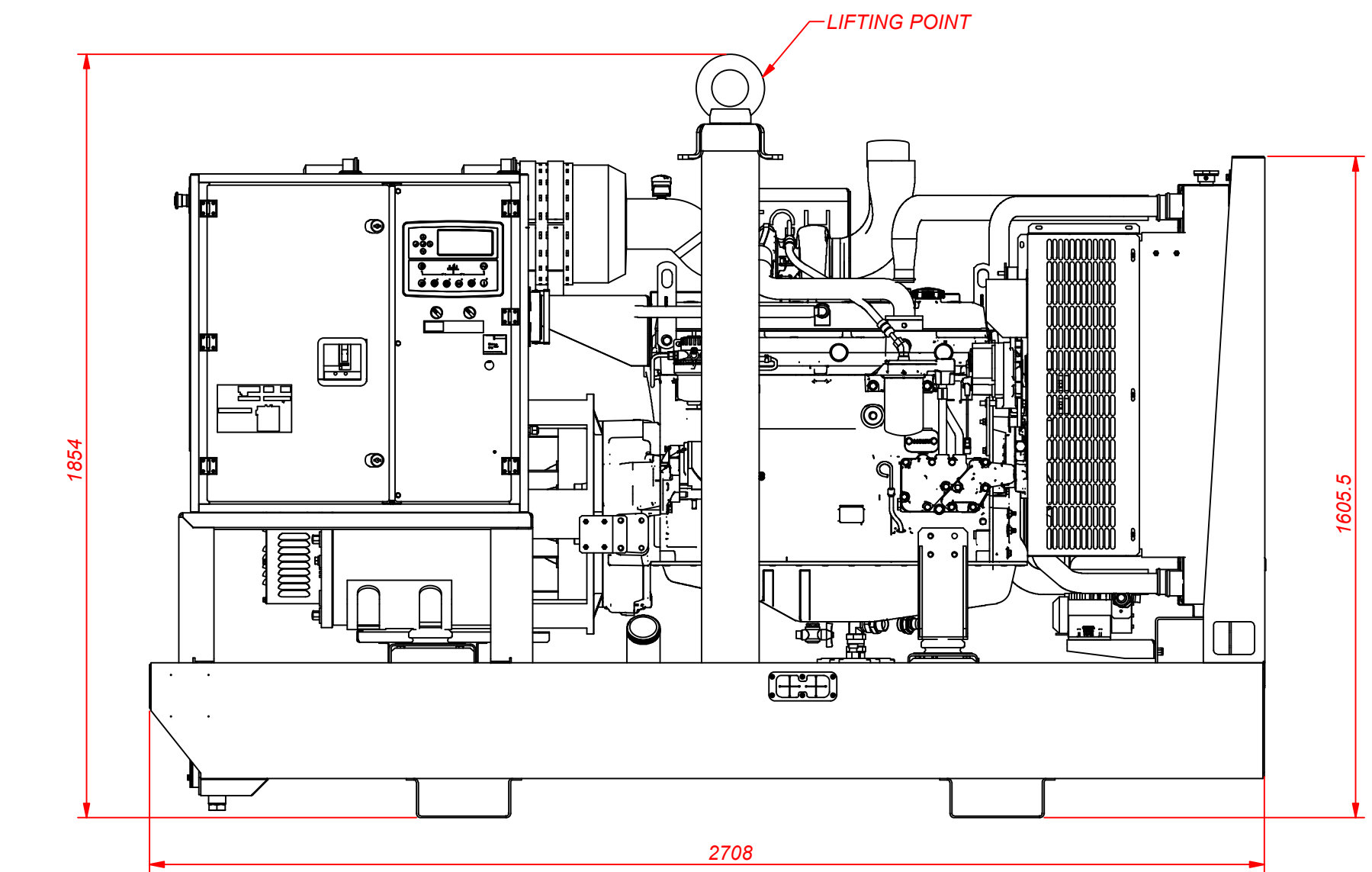
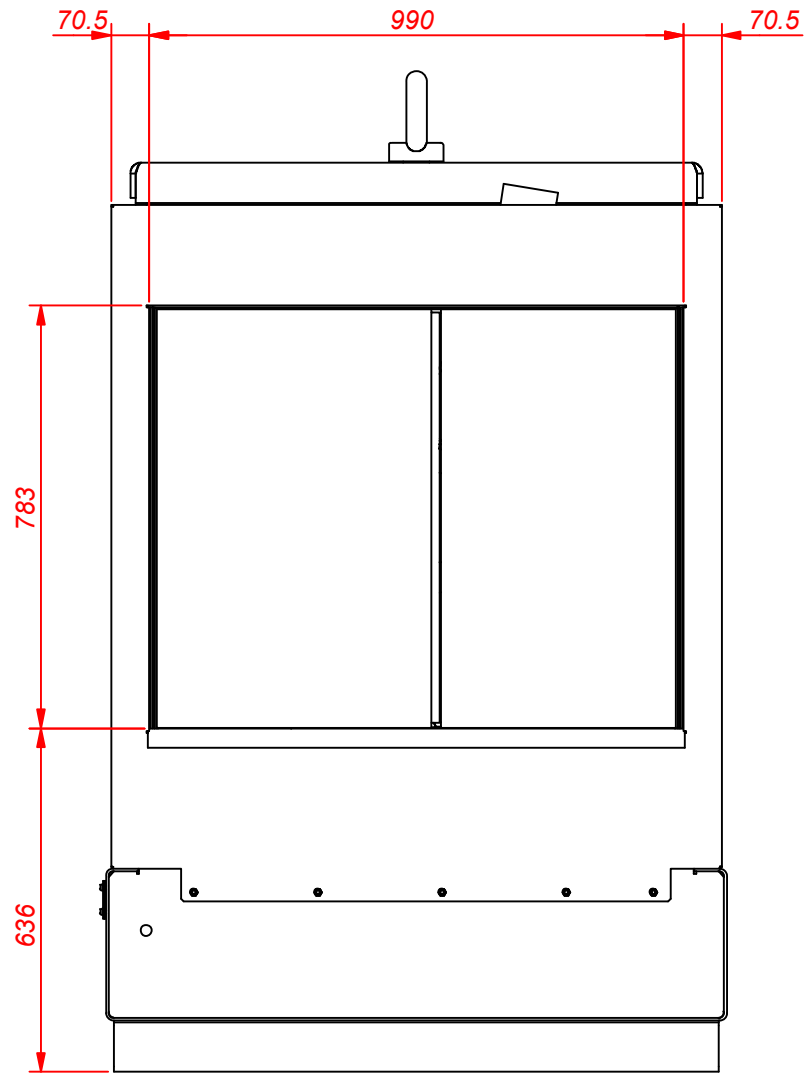
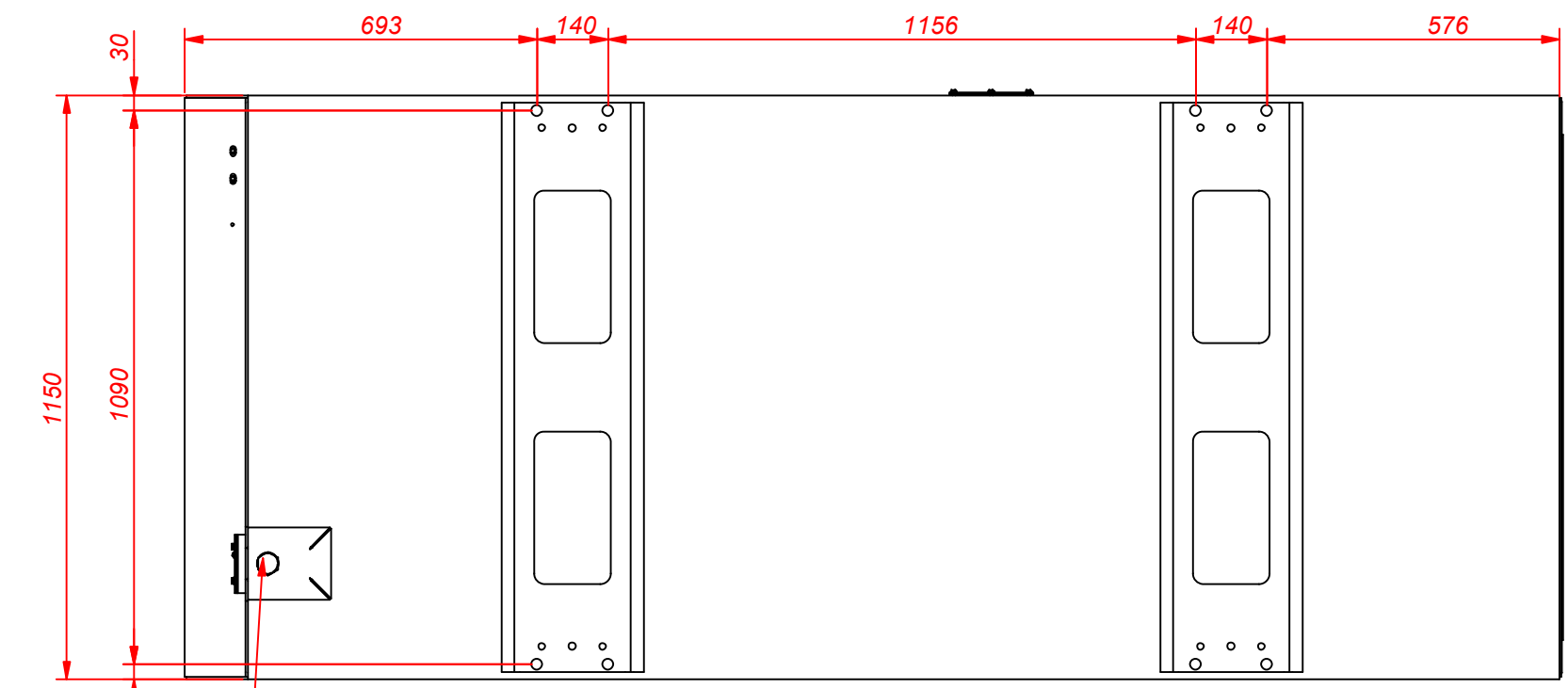

Tolerances, if not indicated, according to:									
Name		DIMENSION DRWG			QIS/CPSG; CD			Confidentiality Class acc. to 1102 K	
Material					Confidential				
Treatment					Thickness: INV			Drawing owner	
		Scale		Family		A2 Compare		Drawing owner	
Drawn by esfh		Blank nr.		Replaces		ESF			
Version Drwg		Blank wt.		Fini wt.		Designation		Sheet 5 / 8	
00		Kg		Kg		1636011127			
STATUS		Des checked.		Prod checked.		Approved.		Date 22/06/2016	
Approved									

CONFIDENTIAL: This document is our property and shall not without our permission be altered, copied, used for manufacturing or communicated to any other person or company.

00					
Ed	Position	Modified from	Date	Intr./Appd.	

1636011127	00
Parent 3D model	3D Model Edition

6068TF220 24h

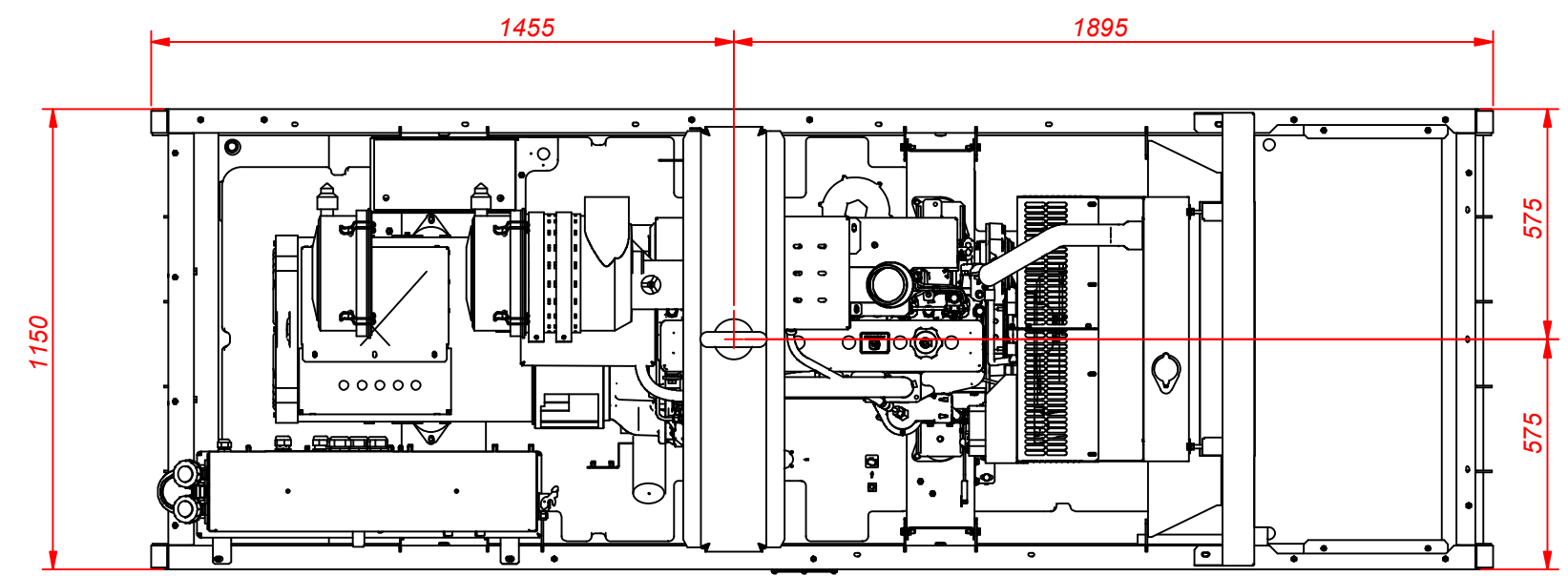
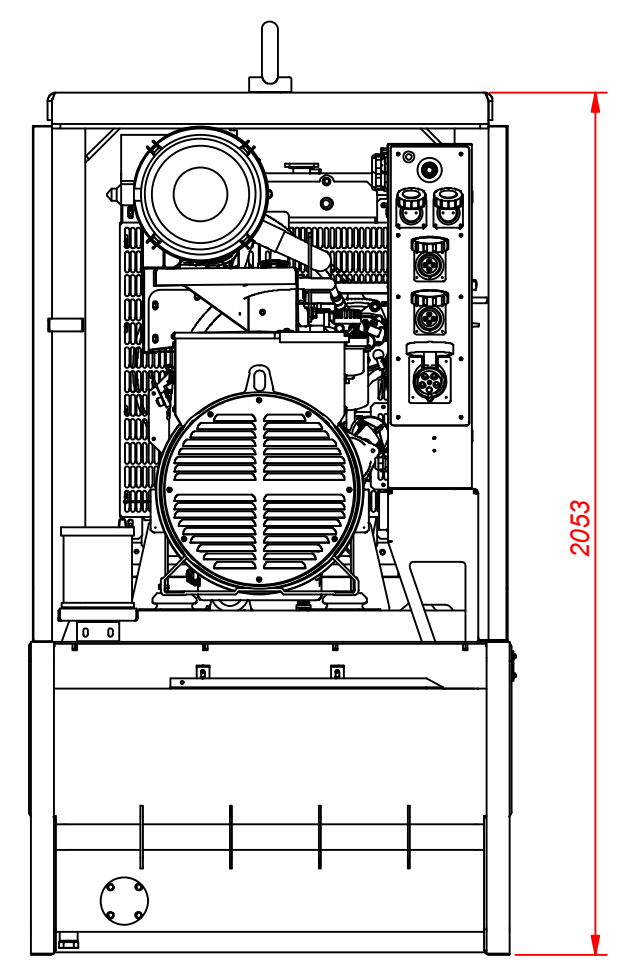
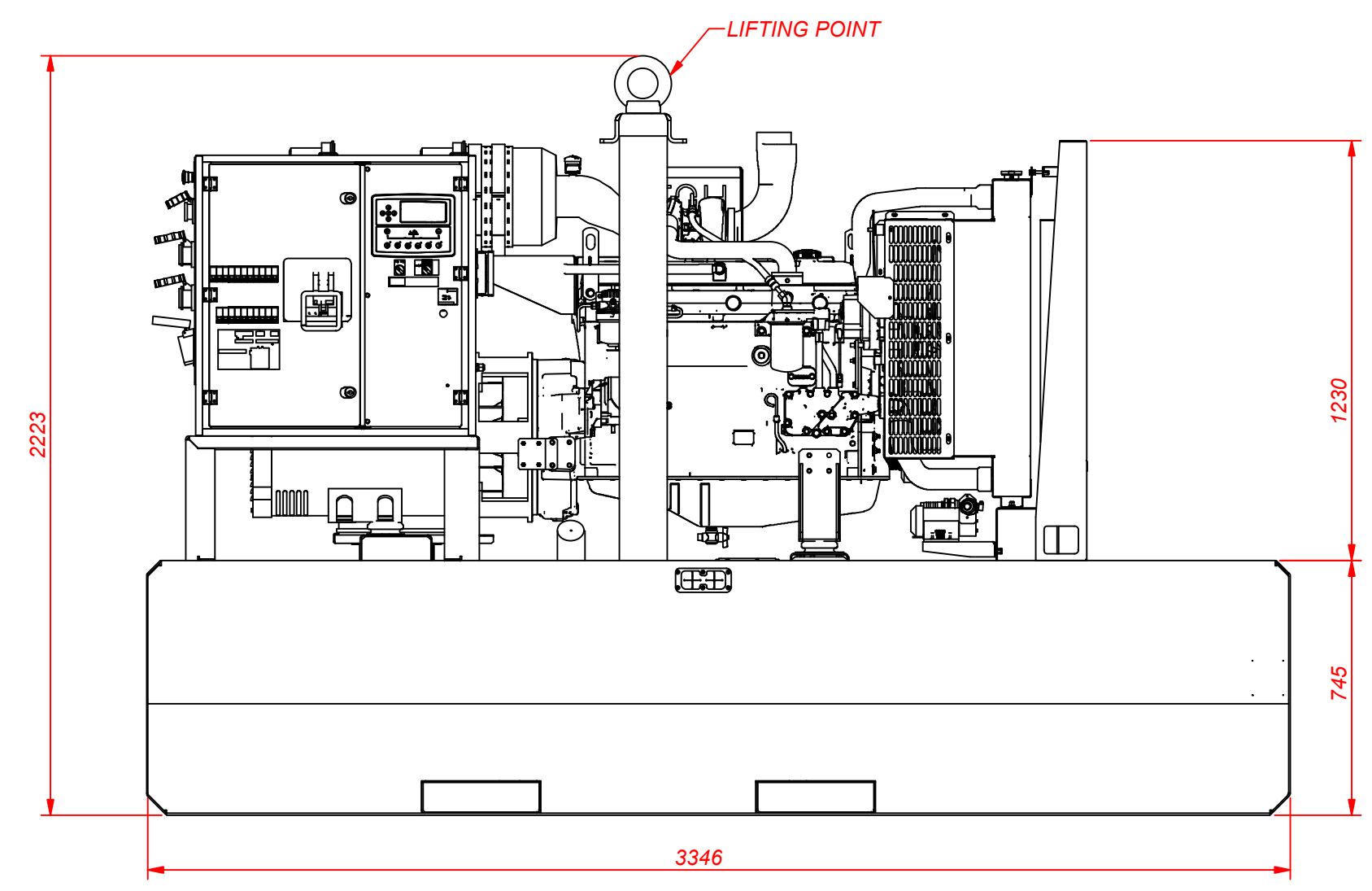
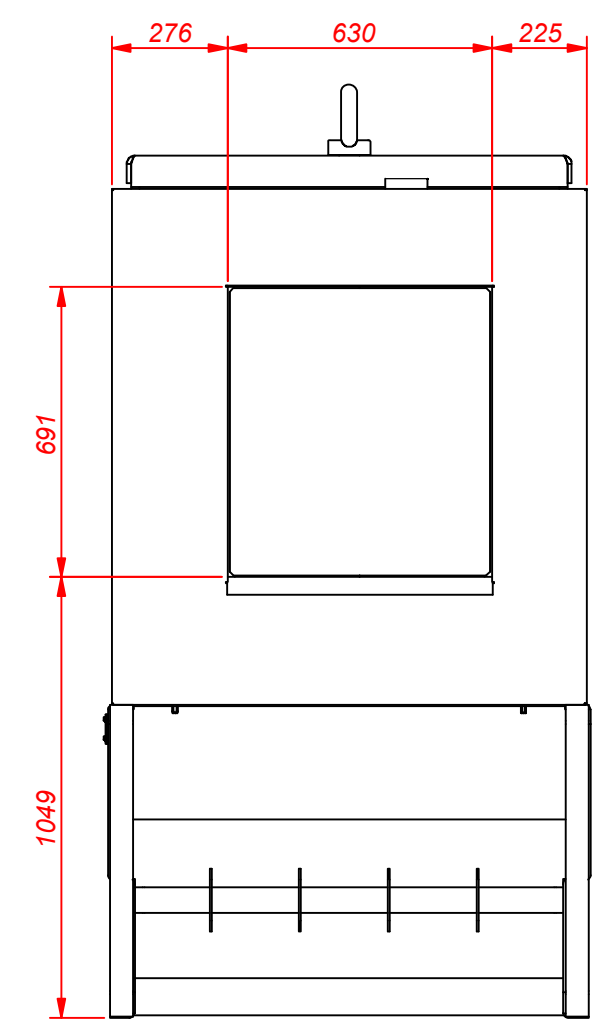
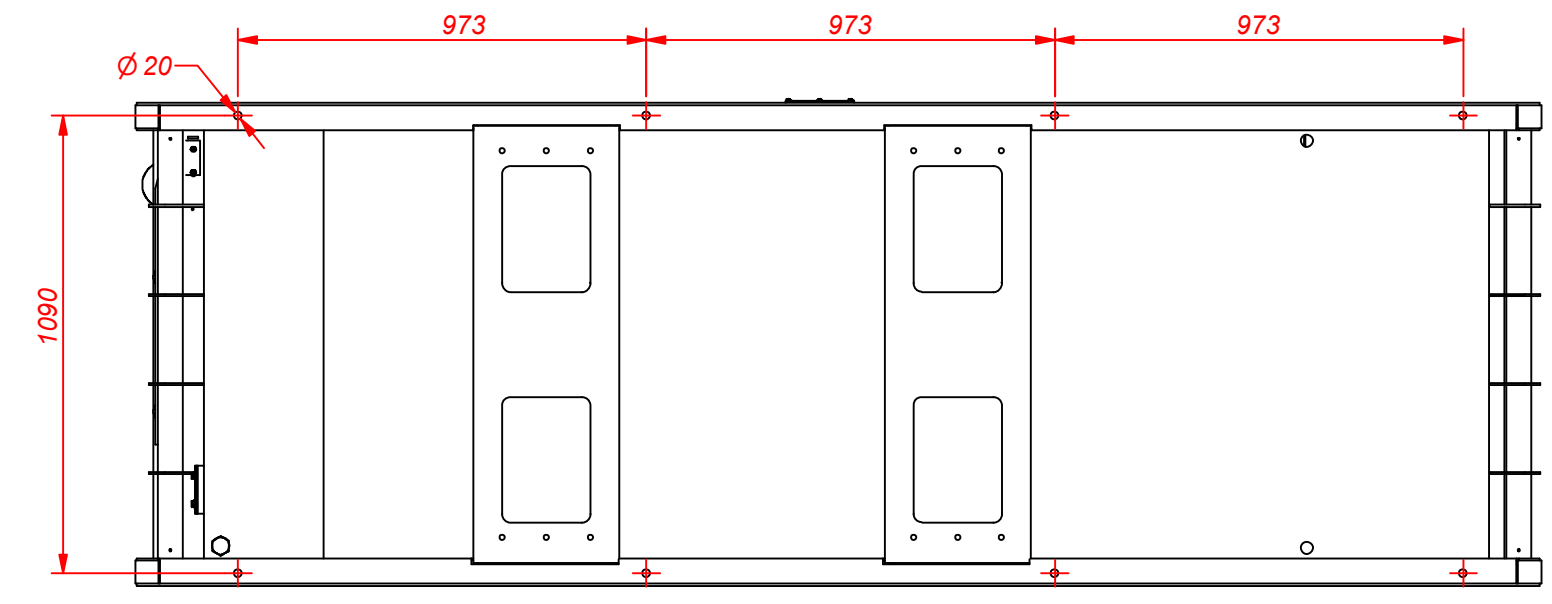

CONFIDENTIAL: This document is our property and shall not without our permission be altered, copied, used for manufacturing or communicated to any other person or company.

00				
Ed	Position	Modified from	Date	Intr./Appd.

1636011127	00
Parent 3D model	3D Model Edition

Tolerances, if not indicated, according to:									
Name		DIMENSION DRWG			QIS/CPSG; CD			Confidentiality Class acc. to 1102 K	
Material					Confidential				
Treatment					Thickness: INV			Drawing owner	
		Scale		Family		A2 Compare			
Drawn by esfh		Blank nr.		Replaces		ESF		Sheet 6 / 8	
Version Drwg 00		Blank wt. Kg		Fini wt. Kg		Designation		1636011127	
Des checked.		Prod checked.		Approved.		Date 22/06/2016			
Approved									

6068HF120 24h

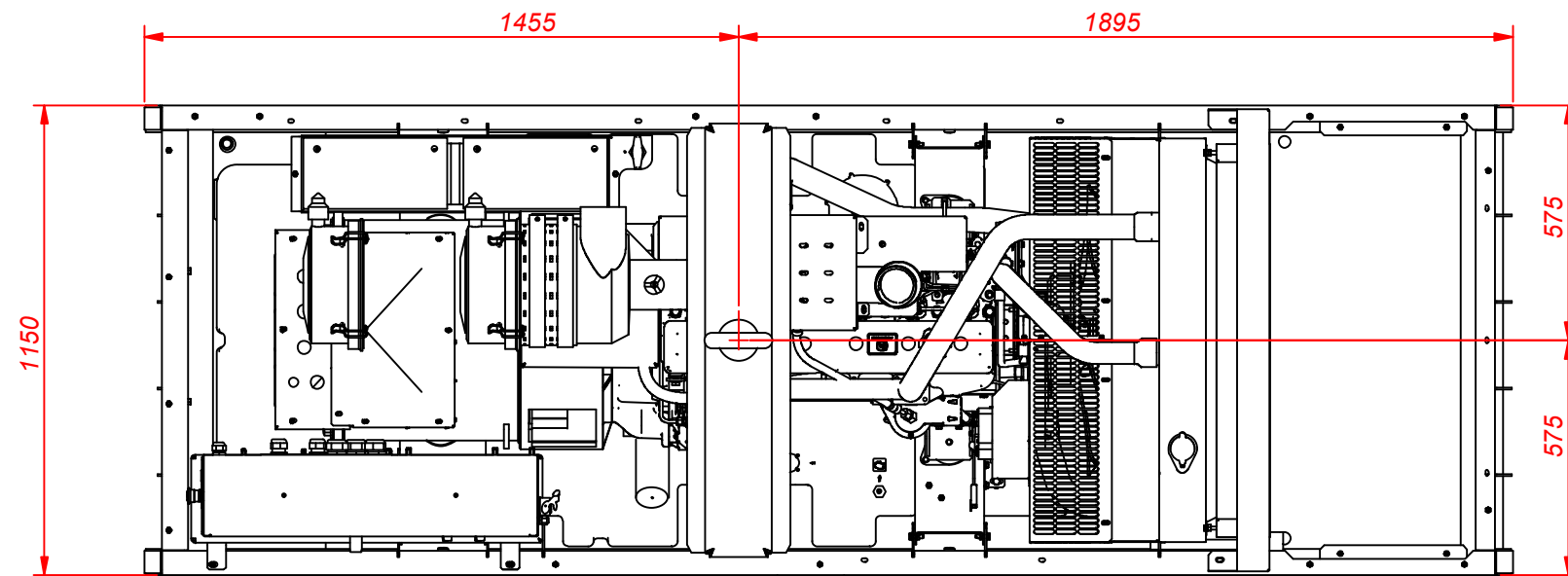
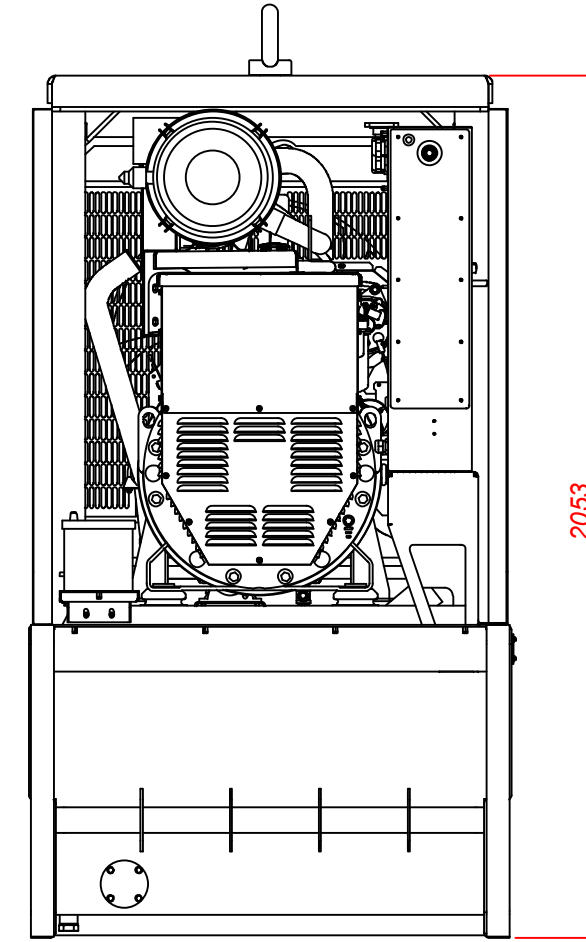
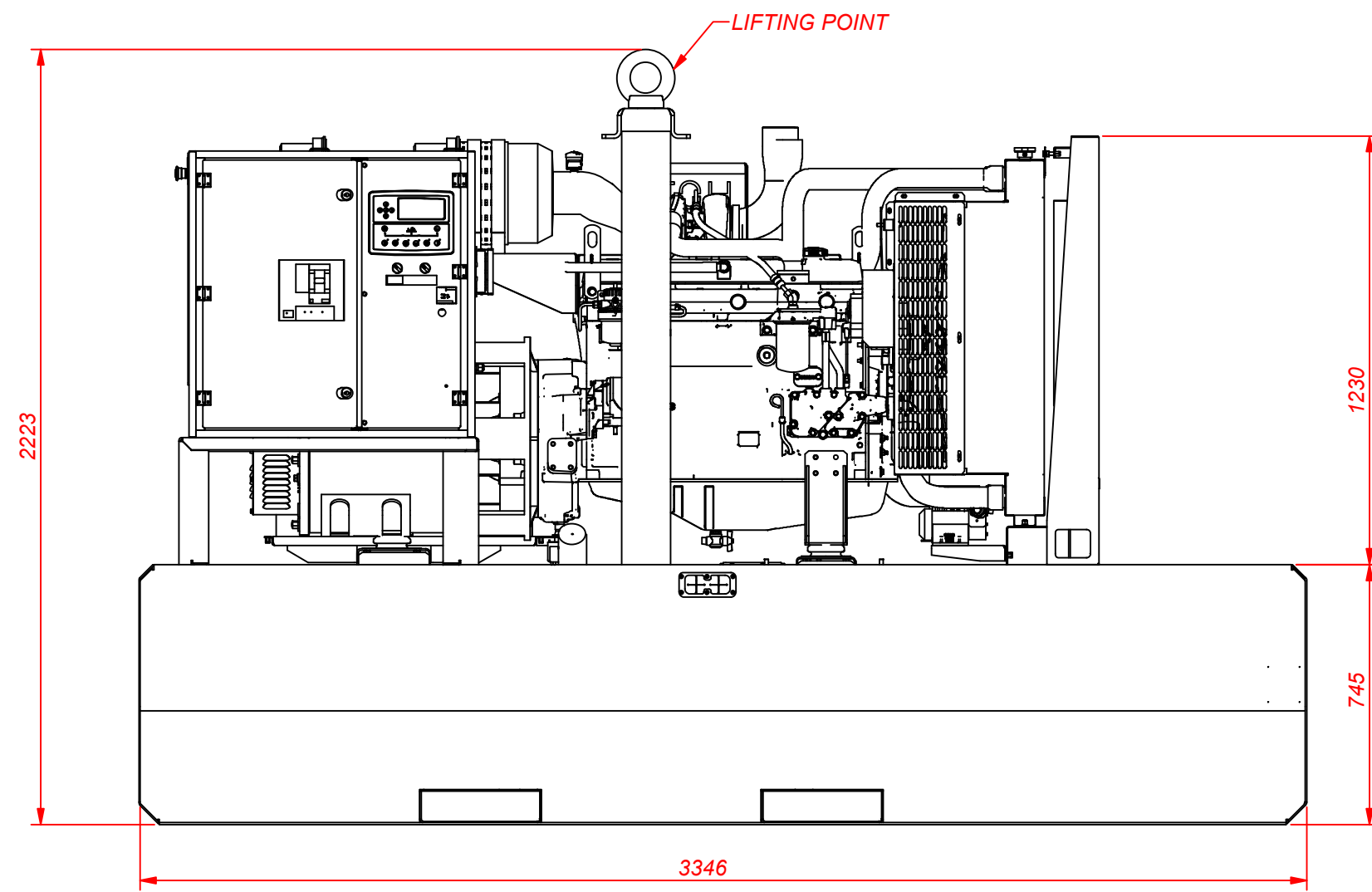
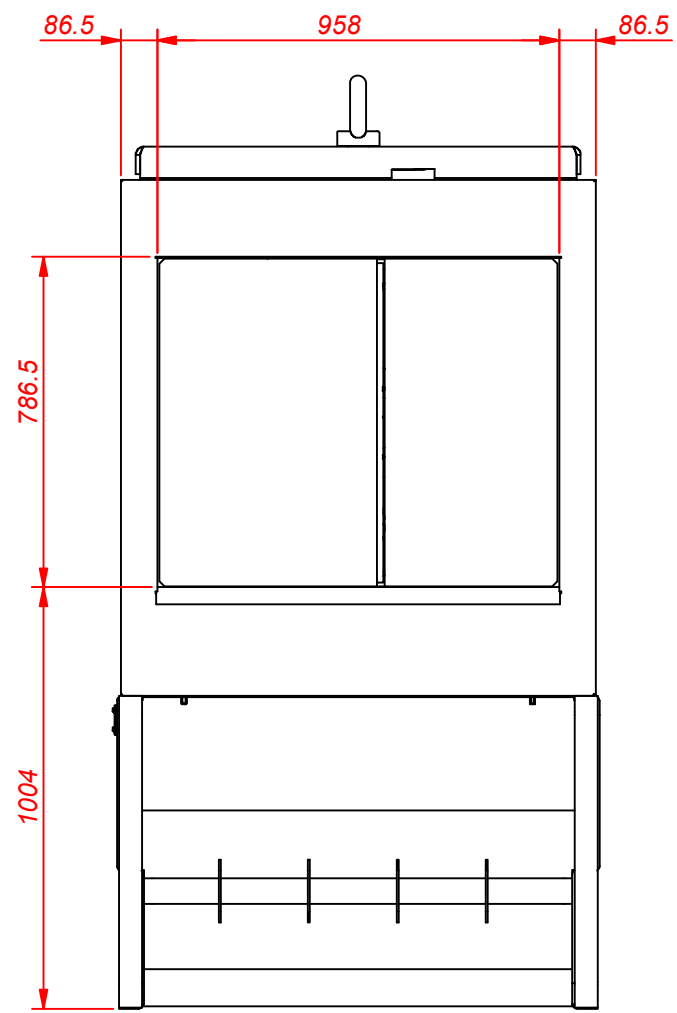
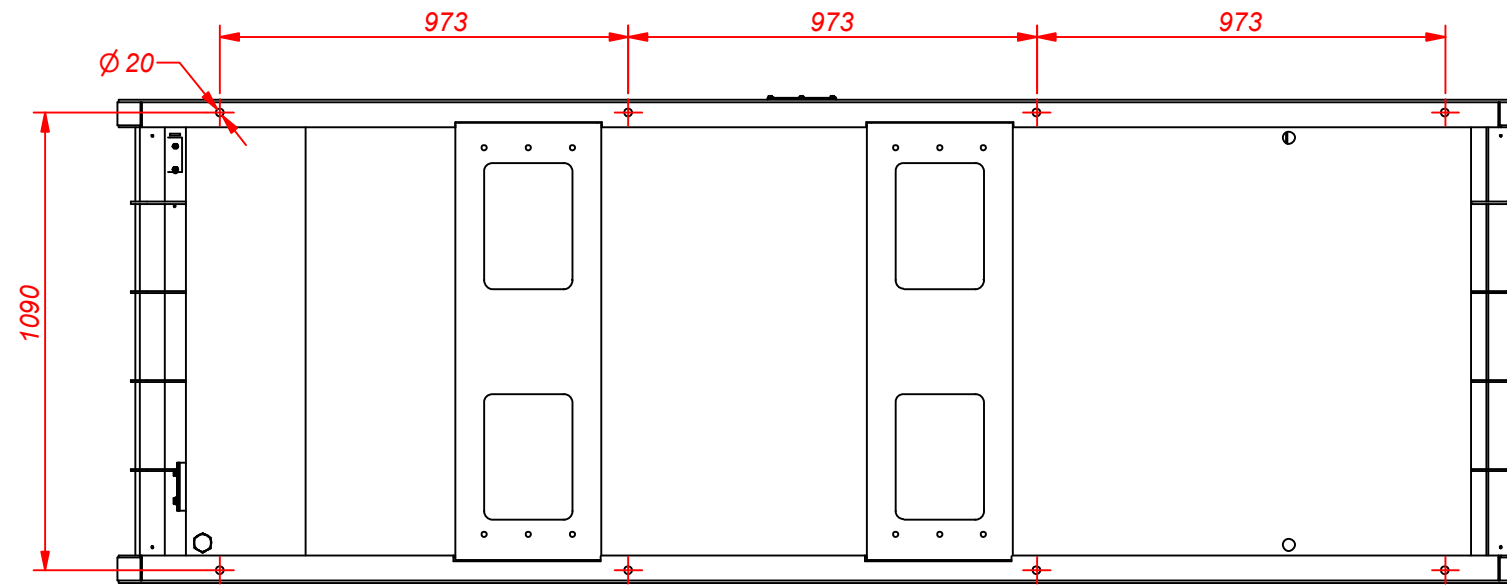

Tolerances, if not indicated, according to:									
Name		DIMENSION DRWG			QIS/CPSG; CD			Confidentiality Class acc. to 1102 K	
Material					Confidential				
Treatment					Thickness: INV			Drawing owner	
		Scale		Family		A2 Compare		ESF	
Ed		Drawn by esfh		Blank nr.		Replaces		Sheet 7 / 8	
00		Version Drwg 00		Blank wt. Kg		Fini wt. Kg		Designation	
Parent 3D model		3D Model Edition		Approved		Des checked. Prod checked. Approved. Date 22/06/2016		1636011127	

CONFIDENTIAL: This document is our property and shall not without our permission be altered, copied, used for manufacturing or communicated to any other person or company.

Ed	Position	Modified from	Date	Intr./Appd.

6068HFG20 24h

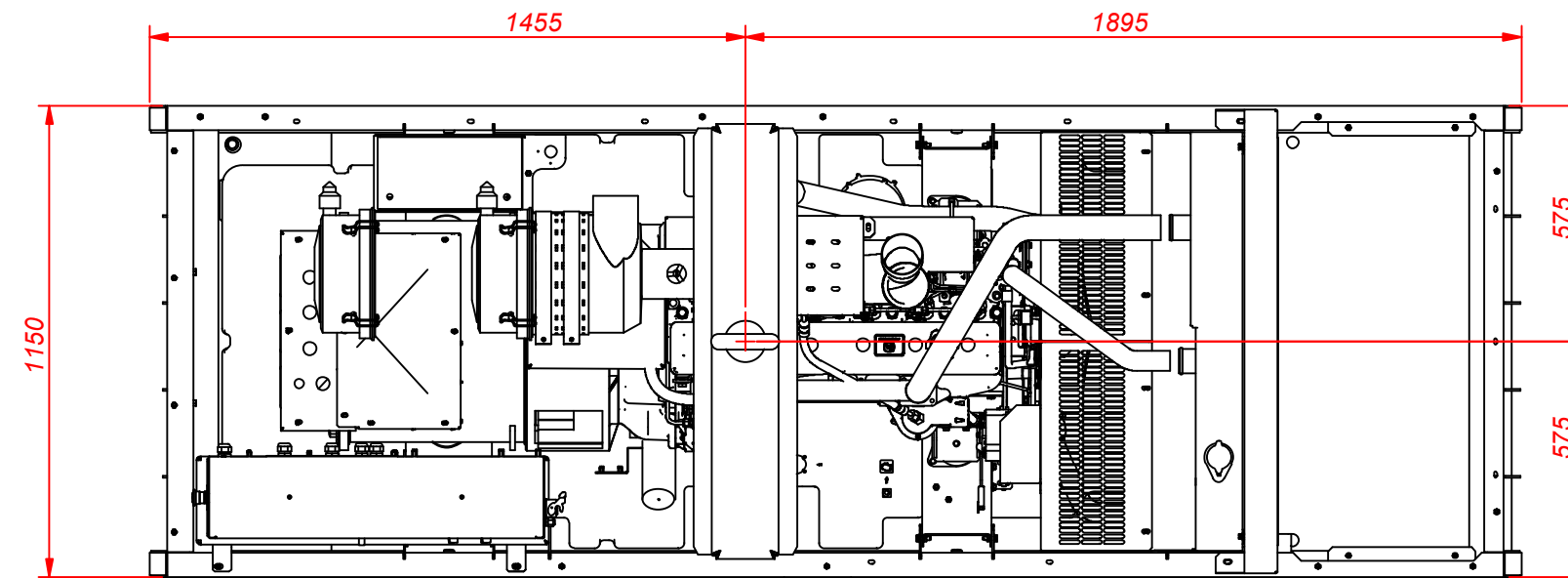
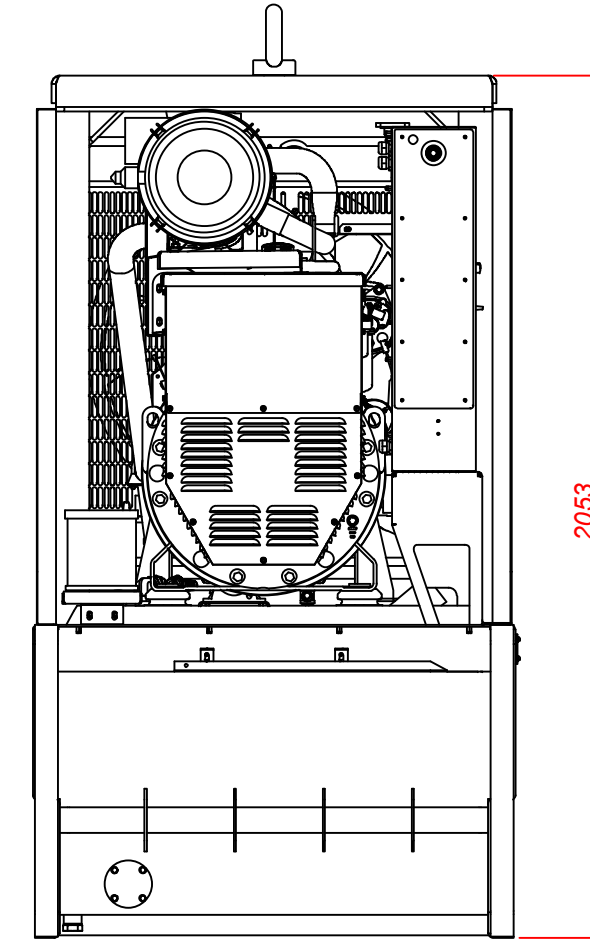
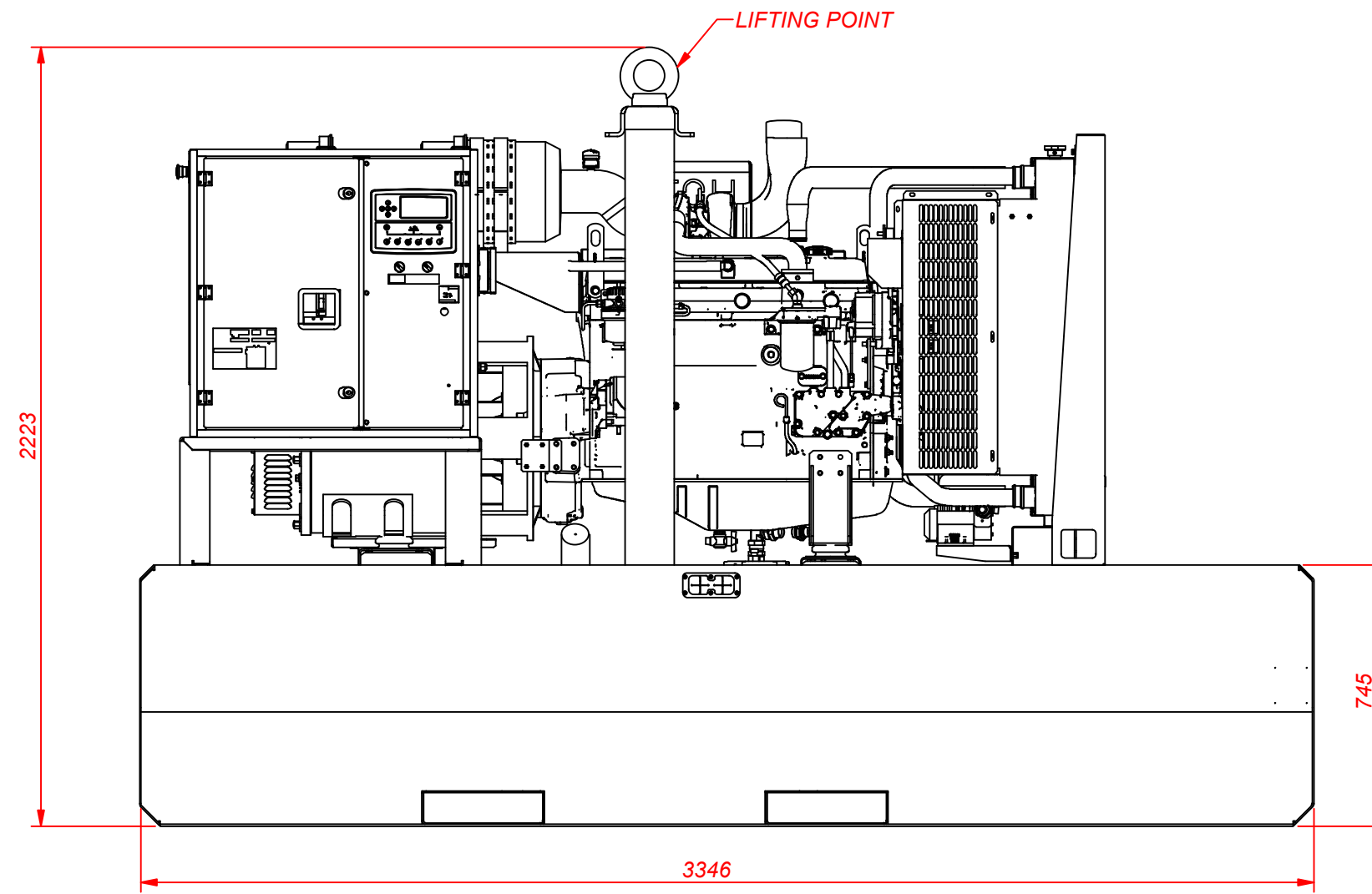
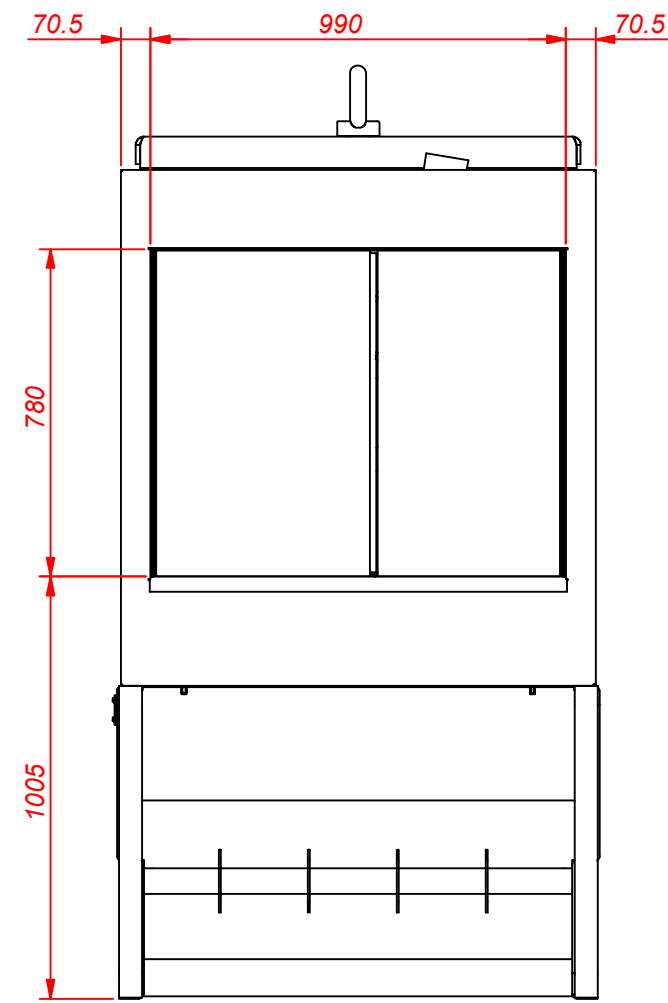
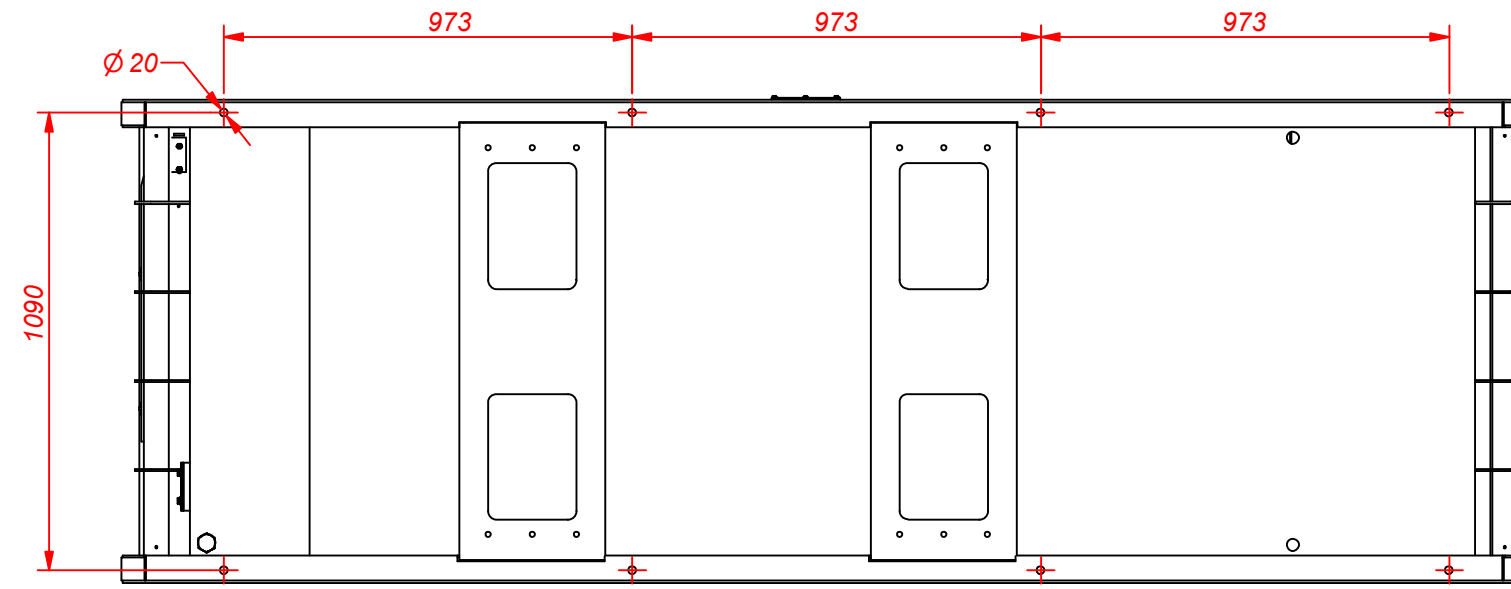

CONFIDENTIAL:
 This document is our property and shall not without our permission be altered, copied, used for manufacturing or communicated to any other person or company.

00				
Ed	Position	Modified from	Date	Intr./Appd.

1636011127	00
Parent 3D model	3D Model Edition

Tolerances, if not indicated, according to:									
Name		DIMENSION DRWG			QIS/CPSG; CD		Confidentiality Class acc. to 1102 K		
Material					Confidential				
Treatment					Thickness: INV		Drawing owner		
		Scale		Family		A2		Compare	
Drawn by esfh		Blank nr.		Replaces		ESF		Sheet 8 / 8	
Version Drwg 00		Blank wt. Kg		Fini wt. Kg		Designation		1636011127	
Des checked.		Prod checked.		Approved.		Date 22/06/2016		1636011127	
STATUS		Approved							