

Uninterruptible power supply - STEP-UPS/24DC/24DC/3/46WH



1081430

<https://www.phoenixcontact.com/gb/products/1081430>

Please be informed that the data shown in this PDF document is generated from our Online Catalog. Please find the complete data in the user documentation. Our General Terms of Use for Downloads are valid.



Uninterruptible power supply with integrated battery module. The STEP-BAT/LI-ION/18.5DC/46WH battery module can be re-ordered separately.

Product Description

UPS modules with integrated energy storage are particularly space saving: UPS module and energy storage are combined in one housing. It's just a case of connecting a power supply upstream.

Your advantages

- Stable supply of sensitive loads, thanks to the regulated output voltage
- Safety ensured, thanks to the integrated protective circuit and energy storage temperature monitoring
- Quick and easy installation, thanks to integrated energy storage
- Battery operation can be stopped via remote contact
- Flexible assembly – can be snapped onto the DIN rail or screwed onto a level surface

Commercial Data

Item number	1081430
Packing unit	1 pc
Minimum order quantity	1 pc
Sales Key	CMUS43
Product Key	CMUS43
Catalog Page	Page 348 (C-4-2019)
GTIN	4055626807850
Weight per Piece (including packing)	510 g
Weight per Piece (excluding packing)	500 g
Customs tariff number	85371091
Country of origin	DE

Uninterruptible power supply - STEP-UPS/24DC/24DC/3/46WH



1081430

<https://www.phoenixcontact.com/gb/products/1081430>

Technical Data

Product properties

Product type	Uninterruptible power supply
IQ technology	no
MTBF (IEC 61709, SN 29500)	> 1401000 h (40 °C)

Insulation characteristics

Protection class	III
Degree of pollution	2

Input data

DC operation

Input voltage	24 V DC
Input voltage range	22.5 V DC ... 29.5 V DC
Voltage type of supply voltage	DC
Buffer period	90 min. (1 A) 45 min. (2 A) 30 min. (3 A) 22 min. (4 A)
Rotary selector switch	Service <input type="checkbox"/> 5 min. 10 min. 20 min.
Current consumption	4.7 A (max.) < 30 mA (No-load) < 0.5 A (Charging (I _{Charge} = max, I _{Out} = 0))
Fixed backup threshold	< 22.5 V
Variable connect threshold	1 V / 1 s
Typical response time	< 0.5 s
Input fuse	7 A (slow-blow, internal)

Output data

Efficiency	> 98 % (Mains operation, with charged energy storage) > 95 % (Battery operation)
Nominal output voltage	24 V DC
Nominal output current (I _N)	3 A (0 °C ... 40 °C)
Output current limit	In mains mode according to connected upstream current limiting device > 4 A (Battery operation)
POWER BOOST (I _{Boost})	4 A (0 °C ... 35 °C)

Uninterruptible power supply - STEP-UPS/24DC/24DC/3/46WH



1081430

<https://www.phoenixcontact.com/gb/products/1081430>

Bridging time	900 s
Derating	35 °C ... 40 °C (5%/K)
Output power	72 W
Power dissipation	0.6 W (No-load)
	2 W (Nominal load)
	4.4 W (I_{max})
	1.1 W (No-load)
	3.8 W (Nominal load)
	10 W (I_{max})
Connection in series	No

Mains operation

Nominal output voltage	24 V DC
Output voltage range	$U_{Out} = U_{In} - 0.3 \text{ V DC}$
Nominal output current (I_N)	3 A (0 °C ... 40 °C)

Battery operation

Nominal output voltage	24 V DC
Output voltage range	23 V DC ... 26.5 V DC ()
Nominal output current (I_N)	3 A (0 °C ... 40 °C)

Signal: Alarm

Output description	Transistor
--------------------	------------

Signal: Battery charge

Output description	Transistor
--------------------	------------

Signal: Battery mode

Output description	Transistor
--------------------	------------

Energy storage

Nominal voltage U_N	18.5 V DC
End-of-charge voltage	18.5 V DC ... 21 V DC
Charging current	0.4 A
Nominal capacity	2.5 Ah
Charging time	5.5 h (max.)
Deep discharge protection	< 15 V DC
Latest startup date (battery only)	12 Months (25 °C)
Battery technology	Lithium-ion
Memory medium	Lithium-ion
Battery presence check (cyclic)	60 s
Quality check of battery	yes, with each charge and cyclically once per month
IQ technology	no

Connection data

Uninterruptible power supply - STEP-UPS/24DC/24DC/3/46WH



1081430

<https://www.phoenixcontact.com/gb/products/1081430>

Input

Connection method	Screw connection
Conductor cross section solid min.	0.2 mm ²
Conductor cross section solid max.	2.5 mm ²
Conductor cross section flexible min.	0.2 mm ²
Conductor cross section flexible max.	2.5 mm ²
Single conductor/flexible terminal point with ferrule with plastic sleeve, min.	0.2 mm ²
Single conductor/flexible terminal point with ferrule with plastic sleeve, max.	2.5 mm ²
Single conductor/flexible terminal point with ferrule without plastic sleeve, min.	0.2 mm ²
Single conductor/flexible terminal point with ferrule without plastic sleeve, max.	2.5 mm ²
Conductor cross section AWG min.	24
Conductor cross section AWG max.	12
Stripping length	6.5 mm
Screw thread	M3
Tightening torque, min	0.6 Nm
Tightening torque max	0.8 Nm

Output

Connection method	Screw connection
Conductor cross section solid min.	0.2 mm ²
Conductor cross section solid max.	2.5 mm ²
Conductor cross section flexible min.	0.2 mm ²
Conductor cross section flexible max.	2.5 mm ²
Single conductor/flexible terminal point with ferrule with plastic sleeve, min.	0.2 mm ²
Single conductor/flexible terminal point with ferrule with plastic sleeve, max.	2.5 mm ²
Single conductor/flexible terminal point with ferrule without plastic sleeve, min.	0.2 mm ²
Single conductor/flexible terminal point with ferrule without plastic sleeve, max.	2.5 mm ²
Conductor cross section AWG min.	24
Conductor cross section AWG max.	12
Stripping length	6.5 mm
Screw thread	M3
Tightening torque, min	0.6 Nm
Tightening torque max	0.8 Nm

Signal

Conductor cross section solid min.	0.2 mm ²
Conductor cross section solid max.	2.5 mm ²

Uninterruptible power supply - STEP-UPS/24DC/24DC/3/46WH



1081430

<https://www.phoenixcontact.com/gb/products/1081430>

Conductor cross section flexible min.	0.2 mm ²
Conductor cross section flexible max.	2.5 mm ²
Single conductor/flexible terminal point with ferrule with plastic sleeve, min.	0.2 mm ²
Single conductor/flexible terminal point with ferrule with plastic sleeve, max.	2.5 mm ²
Single conductor/flexible terminal point with ferrule without plastic sleeve, min.	0.2 mm ²
Single conductor/flexible terminal point with ferrule without plastic sleeve, max.	2.5 mm ²
Conductor cross section AWG min.	24
Conductor cross section AWG max.	12
Stripping length	6.5 mm
Screw thread	M3
Tightening torque, min	0.6 Nm
Tightening torque max	0.8 Nm

LED signaling

Types of signaling	LED
--------------------	-----

Signal output

Signalization designation	Power In OK
Status display	LED
Note on status display	Static to

Signal output: Switching output

Signalization designation	Alarm
Status display	LED
Note on status display	Static to

Signal output: Switching output

Signalization designation	Battery charge
Status display	LED
Note on status display	flashing

Signal output: Switching output

Signalization designation	Battery mode
Status display	LED
Note on status display	Static to

Signal output

Signalization designation	Overload
Status display	LED
Note on status display	flashing

Signal output

Signalization designation	Service/Battery Error
---------------------------	-----------------------

Uninterruptible power supply - STEP-UPS/24DC/24DC/3/46WH



1081430

<https://www.phoenixcontact.com/gb/products/1081430>

Status display	LED
Note on status display	flashing

Dimensions

Width	108 mm
Height	90 mm
Depth	71 mm

Installation dimensions

Installation distance right/left	0 mm / 0 mm
Installation distance top/bottom	30 mm / 30 mm

Material specifications

Housing material	Plastic
Type of housing	Plastic
Foot latch material	POM (Polyoxymethylene)
Housing material	Polycarbonate

Environmental and real-life conditions

Ambient conditions

Degree of protection	IP20
Ambient temperature (operation)	0 °C ... 40 °C
Ambient temperature (storage/transport)	-20 °C ... 45 °C
Climatic class	3K3 (in acc. with EN 60721)
Max. permissible relative humidity (operation)	≤ 95 % (at 25 °C, non-condensing)
Shock	18 ms, 30g, in each space direction (according to IEC 60068-2-27)
Vibration (operation)	< 15 Hz, amplitude ±2.5 mm (according to IEC 60068-2-6) 15 Hz ... 150 Hz, 2.3g, 90 min.

Approval data

UL approvals	UL/C-UL listed UL 508
	UL/C-UL Recognized UL 60950-1

EMC data

Electromagnetic compatibility	Conformance with EMC Directive 2014/30/EU
EMC requirements for noise immunity	EN 61000-6-2
Noise immunity	EN 61000-6-2

Electrostatic discharge

Standards/regulations	EN 61000-4-2
-----------------------	--------------

Electrostatic discharge

Contact discharge	6 kV (Test Level 3)
-------------------	---------------------

Uninterruptible power supply - STEP-UPS/24DC/24DC/3/46WH



1081430

<https://www.phoenixcontact.com/gb/products/1081430>

Discharge in air	8 kV (Test Level 3)
Comments	Criterion A

Electromagnetic HF field

Standards/regulations	EN 61000-4-3
-----------------------	--------------

Electromagnetic HF field

Frequency range	80 MHz ... 1 GHz
Test field strength	10 V/m (Test Level 3)
Frequency range	1 GHz ... 6 GHz
Test field strength	10 V/m (Test Level 3)
Comments	Criterion A

Fast transients (burst)

Standards/regulations	EN 61000-4-4
-----------------------	--------------

Fast transients (burst)

Input	2 kV (Test Level 3 - asymmetrical)
Output	2 kV (Test Level 3 - asymmetrical)
Signal	2 kV (Test Level 4 - asymmetrical)
Comments	Criterion A

Surge voltage load (surge)

Standards/regulations	EN 61000-4-5
Input	1 kV (Test Level 2 - symmetrical)
	2 kV (Test Level 3 - asymmetrical)
Output	1 kV (Test Level 2 - symmetrical)
	2 kV (Test Level 3 - asymmetrical)
Signal	1 kV (Test Level 2 - asymmetrical)
Comments	Criterion A

Conducted interference

Standards/regulations	EN 61000-4-6
-----------------------	--------------

Conducted interference

I/O/S	asymmetrical
Frequency range	0.15 MHz ... 80 MHz
Comments	Criterion A
Voltage	10 V (Test Level 3)

Emitted interference

Standards/regulations	EN 61000-6-3
Radio interference voltage in acc. with EN 55011	EN 55011 (EN 55022) Class B, area of application: Industry and residential
Emitted radio interference in acc. with EN 55011	EN 55011 (EN 55022) Class B, area of application: Industry and residential

Uninterruptible power supply - STEP-UPS/24DC/24DC/3/46WH



1081430

<https://www.phoenixcontact.com/gb/products/1081430>

Criteria

Criterion A	Normal operating behavior within the specified limits.
Criterion B	Temporary impairment to operational behavior that is corrected by the device itself.

Standards and regulations

Standard – Electronic equipment for use in electrical power installations and their assembly into electrical power installations	EN 50178/VDE 0160 (PELV)
Standard - Electrical safety	IEC 62368-1 (SELV)

Mounting

Mounting type	DIN rail mounting
Assembly instructions	alignable: horizontally 0 mm, vertically 50 mm
Mounting position	horizontal DIN rail NS 35, EN 60715

Uninterruptible power supply - STEP-UPS/24DC/24DC/3/46WH

1081430

<https://www.phoenixcontact.com/gb/products/1081430>

Drawings

Block diagram

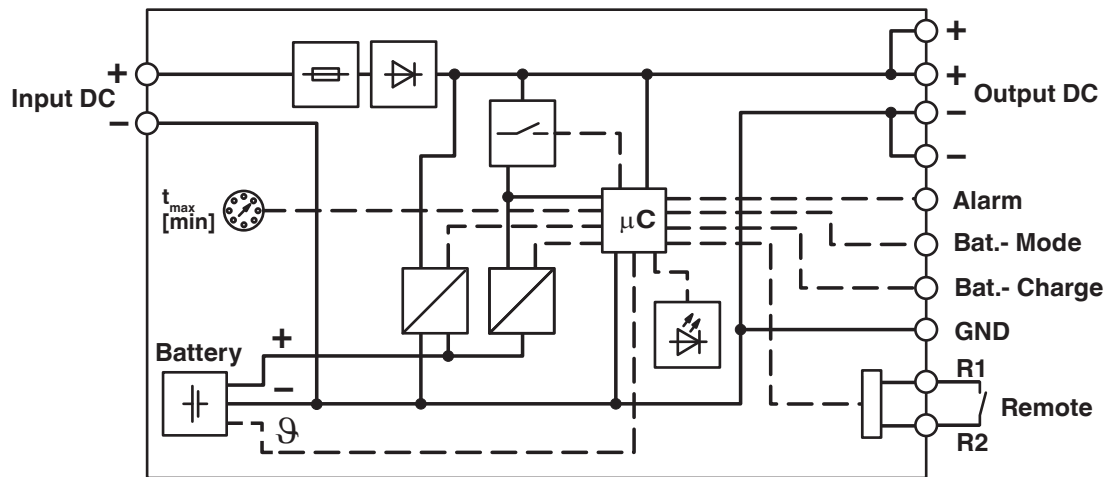

Uninterruptible power supply - STEP-UPS/24DC/24DC/3/46WH



1081430

<https://www.phoenixcontact.com/gb/products/1081430>

Approvals



cULus Listed

Approval ID: FILE E 214596



cULus Listed

Approval ID: FILE E 123528



EAC

Approval ID: RU S-DE.BL08.W.00764



KC

Approval ID: R-R-PCK-1081430

Uninterruptible power supply - STEP-UPS/24DC/24DC/3/46WH



1081430

<https://www.phoenixcontact.com/gb/products/1081430>

Classifications

ECLASS

ECLASS-9.0	27040705
ECLASS-10.0.1	27040705
ECLASS-11.0	27040705

ETIM

ETIM 8.0	EC000382
----------	----------

UNSPSC

UNSPSC 21.0	39121000
-------------	----------

Uninterruptible power supply - STEP-UPS/24DC/24DC/3/46WH



1081430

<https://www.phoenixcontact.com/gb/products/1081430>

Environmental Product Compliance

REACH SVHC	Lead 7439-92-1
China RoHS	Environmentally Friendly Use Period = 25; For information on hazardous substances, refer to the manufacturer's declaration available under "Downloads"

Uninterruptible power supply - STEP-UPS/24DC/24DC/3/46WH

1081430

<https://www.phoenixcontact.com/gb/products/1081430>

Accessories

Energy storage

Energy storage - STEP-BAT/LI-ION/18.5DC/46WH - 1081355

<https://www.phoenixcontact.com/gb/products/1081355>

Energy storage, lithium-ion, 18.5 V DC, 46 Wh



Power supply unit

Power supply unit - STEP-PS/ 1AC/24DC/4.2 - 2868664

<https://www.phoenixcontact.com/gb/products/2868664>

Primary-switched STEP POWER power supply for DIN rail mounting, input: 1-phase, output: 24 V DC/4.2 A



Uninterruptible power supply - STEP-UPS/24DC/24DC/3/46WH



1081430

<https://www.phoenixcontact.com/gb/products/1081430>

Power supply unit

Power supply unit - STEP3-PS/1AC/24DC/5/PT - 1088478

<https://www.phoenixcontact.com/gb/products/1088478>



Primary-switched power supply unit, STEP POWER, Push-in connection, DIN rail mounting, input: 1-phase, output: 24 V DC / 5 A

Phoenix Contact 2023 © - all rights reserved
<https://www.phoenixcontact.com>

PHOENIX CONTACT Ltd
Halesfield 13, Telford
Shropshire, TF7 4PG
01952 681700
info@phoenixcontact.co.uk