

Network analyzer

# M4M 20

# M4M 20-M

# User manual





---

# Table of Contents

<b>1.General information.....</b>	<b>5</b>
1.1.Use and storage of the manual.....	5
1.2.Copyright .....	5
1.3.Liability disclaimer .....	5
1.4.General safety warnings .....	5
1.5.Cyber Security Disclaimer.....	6
<b>2.Packaging contents.....</b>	<b>7</b>
<b>3.Technical characteristics .....</b>	<b>8</b>
3.1.Description of the device .....	8
3.2.Product Marking.....	8
3.3.Main functionalities.....	9
3.4.Versions.....	10
3.5.Overall dimensions .....	10
3.6.Technical data.....	11
<b>4.Measurement method.....</b>	<b>16</b>
4.1.Vector registration method .....	16
<b>5.Installation .....</b>	<b>17</b>
5.1.Assembly M4M 20 .....	17
5.2.Disassembly M4M 20 .....	18
5.3.Disassembly M4M 20: .....	18
5.4.Wiring diagrams.....	19
<b>6.Access to device .....</b>	<b>25</b>
6.1.Homepage .....	25
6.2.Navigation symbols .....	26
6.3.Notification icons .....	26
6.4.Overview of menu displays.....	27
6.5.Data entry.....	28
6.6.Favourite page .....	29
<b>7.First commissioning .....</b>	<b>30</b>
7.1.Setting language .....	30
7.2.Password for the first use .....	30
7.3.Date and time.....	31
7.4.Type of network.....	31
7.5.CT ratio.....	32
7.6.VT ratio .....	34

7.7.Lock MID version .....	35
<b>8.Configuration .....</b>	<b>36</b>
8.1.Unit.....	36
8.2.Installation .....	41
8.3.Inputs / Outputs.....	43
8.4.Alarms.....	46
8.5.Communication.....	48
8.6.Other settings .....	51
<b>9.Data Reading .....</b>	<b>53</b>
9.1.Realtime .....	54
9.2.Energy .....	55
9.3.Power Quality .....	56
9.4.Average.....	57
9.5.Min Value .....	58
9.6.Max Value .....	59
9.7.I/O .....	60
9.8.Notifications .....	60
9.9. Power outages .....	63
9.10.Timers .....	64
<b>10.Graphs .....</b>	<b>65</b>
<b>11.Maintenance .....</b>	<b>66</b>

---

# 1. General information

---

## 1.1. Use and storage of the manual

Carefully read this manual and adhere to the indications described prior to using the device.

This manual contains all of the safety information, the technical aspects and the operations necessary to ensure the correct use of the device and maintain it in safe conditions.

---

## 1.2. Copyright

The copyright of this manual is the property of ABB S.p.A.

This manual contains texts, designs and illustrations of a technical nature which must not be disclosed or transmitted to third parties, even partially, without the written authorisation of ABB S.p.A.

---

## 1.3. Liability disclaimer

The information contained in this document is subject to change without notice and cannot be considered as an obligation by ABB S.p.A. ABB S.p.A. is not liable for any errors that may appear in this document. ABB S.p.A. is not liable under any circumstances for any direct, indirect, special, incidental or consequential damage of any kind that may arise from using this document. ABB S.p.A. is also not liable for incidental or consequential damage that may arise from using the software or hardware mentioned in this document.

---

## 1.4. General safety warnings



Non-adherence to the following points can lead to serious injury or death.

Use the suitable personal protection devices and adhere to the current regulations governing electrical safety.

- This device must be installed exclusively by qualified personnel who have read all of the information relative to the installation.
- Check that the voltage supply and measurement are compatible with the range permitted by the device.
- Ensure that all current and voltage supplies are disconnected prior to carrying out any controls, visual inspections and tests on the device.
- Always assume that all circuits are under voltage until they are completely disconnected, subjected to tests and labelled.
- Disconnect all of the power supply prior to working on the device.
- Always use a suitable voltage detection device to check that the supply is interrupted.
- Pay attention to any dangers and carefully check the work area ensuring that no instruments or foreign objects have been left inside the compartment in which the device is housed.
- The correct use of this device depends on a correct manipulation, installation and use.hdfh
- Failure to adhere to the basic installation information can lead to injuries as well as damage to the electric instruments or to any other product.
- **NEVER** connect an external fuse in by-pass.
- Disconnect all of the input and output wires before carrying out a dielectric rigidity test or an insulation test on an instrument in which the device is installed.
- The tests carried out at a high voltage can damage the device's electronic components.
- The device has to be installed inside a switchboard.
- Installation of M4M shall include a switch or circuit breaker for the connection of auxiliary supply and voltage measurement. The switch or circuit breaker must be suitably located and easily reachable and must be marked as the disconnecting device for M4M.
- Switch off circuit breaker or switch before disconnecting from the auxiliary supply and voltage measurement or connecting to the auxiliary supply or voltage measurement.

---

## 1.5. Cyber Security Disclaimer

M4M 20 network analyzer is designed to be connected and to communicate information and data via a network interface, which should be connected to a secure network. It is your sole responsibility to provide and continuously ensure a secure connection between the product and your network or any other network (as the case may be) and to establish and maintain appropriate measures (such as but not limited to the installation of firewalls, application of authentication measures, encryption of data, installation of antivirus programs, etc.) to protect the M4M 20 network analyzer product, the network, its system and interfaces against any kind of security breaches, unauthorized access, interference, intrusion, leakage and/or theft of data or information. ABB S.p.A. and its affiliates are not liable for damages and/or losses related to such security breaches, unauthorized access, interference, intrusion, leakage and/or theft of data or information.

Although ABB S.p.A. provides functionality testing on the products and updates that we release, you should institute your own testing program for any product updates or other major system updates (to include but not limited to code changes, configuration file changes, third party software updates or patches, hardware change out, etc.) to ensure that the security measures that you have implemented have not been compromised and system functionality in your environment is as expected.

## 2. Packaging contents

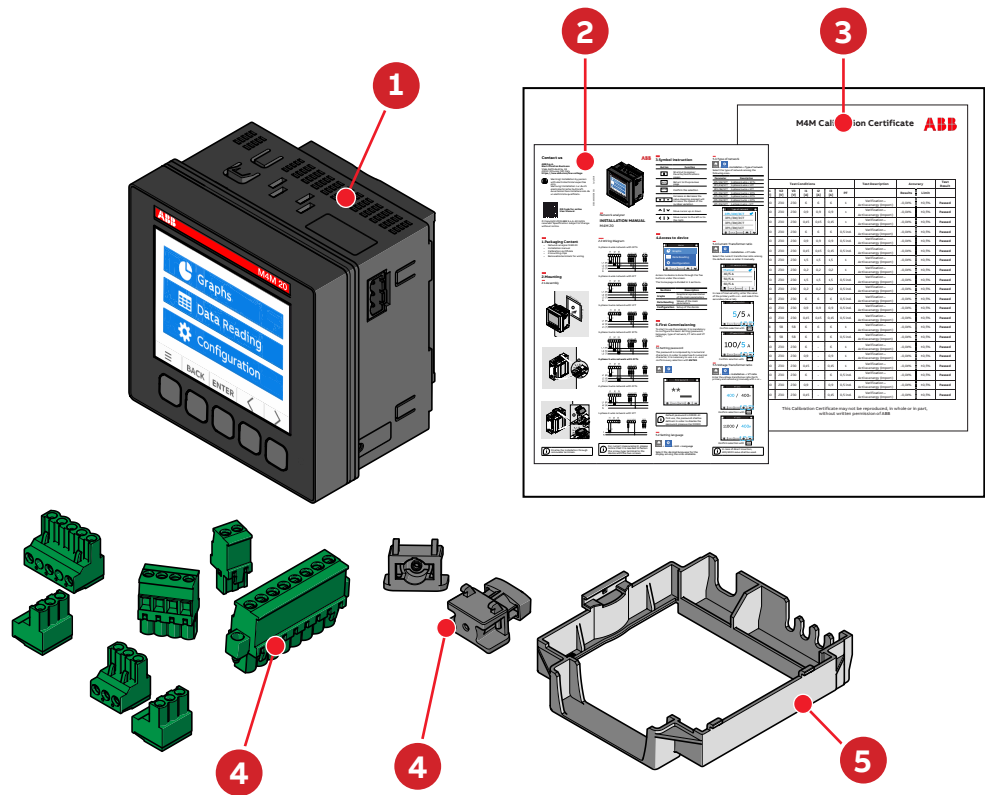

### Packaging contents

1	Network analyzer M4M 20 or M4M 20-M (MID)
2	Installation manual
3	Calibration certificate
4	Installation accessories (removable terminals, fixing clips)
5	M4M 20-M (MID): Sealable terminal block

The number and type of removable terminals in the package varies according to the different versions. Please refer to below table to check the removable terminals included in each package.

Product Name	Current input terminal (6 poles)	Voltage input terminal (4 poles)	Auxiliary supply terminal (2 poles)	Digital outputs terminal (3 poles)	Programmable I/O terminal (3 poles)	Analogue output terminal (3 poles)	RS485 terminal (3 poles)
M4M 20	X	X	X	X	-	-	-
M4M 20 MODBUS	X	X	X	X	-	-	X
M4M 20-M MODBUS	X	X	X	X	-	-	X
M4M 20 ETHERNET	X	X	X	X	-	-	-
M4M 20-M ETHERNET	X	X	X	X	-	-	-
M4M 20 PROFIBUS	X	X	X	X	-	-	-
M4M 20 I/O	X	X	X	X	X	X	X
M4M 20 BACNET	X	X	X	X	-	-	-
M4M 20 ROGOWSKI	-	X	X	X	-	-	X

Please notice that terminals for current input on M4M 20 Rogowski are pre-wired on ABB's R4M Rogowski coils

## 3. Technical characteristics

### 3.1. Description of the device

M4M 20 is ABB's network analyzer range that provides complete and accurate electrical parameters monitoring and basic power quality analysis.

Equipped with graphic color display for advanced visualization of the measured parameters and Bluetooth module for smart commissioning.

### 3.2. Product Marking

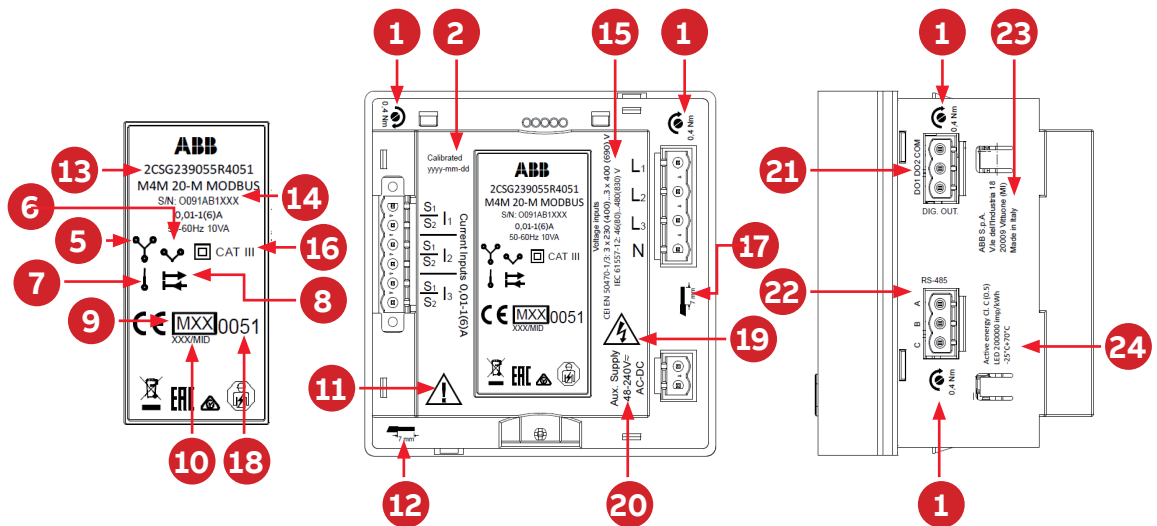

Packaging contents			
1	Tightening torque	13	Product code
2	Calibration date	14	Serial number
3	Current	15	Voltage inputs
4	Frequency	16	Protection class II, Cat III
5	3-element metering	17	Cable strip
6	2-element metering	18	Notified body
7	1-element metering	19	Caution, possibility of electric shock
8	Import/Export	20	Auxiliary supply
9	MID and year of verification	21	Digital output connection
10	MID certificate number	22	RS485 connectoin
11	Caution, refer to accompanying document	23	Manufacturer information
12	Cable strip	24	Accuracy class, LED pulse frequency, operating temperature

### 3.3.Main functionalities

<b>Real-time</b>	
TRMS current	•
TRMS Voltage	•
Frequency	•
Active, Reactive and Apparent Power	•
Power Factor	•
Operating timer, countdown timer	•
<b>Energy</b>	
Active, Reactive and Apparent Energy	•
4 quadrant Energy (Import/Export)	•
<b>Power quality</b>	
THD (I, VLN, VLL)	•
Neutral current	Calculated
<b>Data recording and logs</b>	
Single alarms	25
Warnings, alarms and errors logs	•
Demand values (average) Basic Advanced	Basic
Min/Max Demand values Basic Advanced	Basic
<b>HMI</b>	
Graphs visualization	Basic
Notifications	•
Homepage and favourite page	•
Password protection	•
<b>Connectivity</b>	
Automatic integration in ABB Ability™ EDCS	•
Bluetooth Low Energy	•
Communication Protocols	Modbus RTU, Modbus TCP/IP, Profibus DP-V0, BACnet/IP

### 3.4. Versions

Product Name	I/O	Communication protocol
M4M 20	2 Digital Outputs	Bluetooth
M4M 20 MODBUS	2 Digital Outputs	Modbus RTU, Bluetooth
M4M 20-M MODBUS	2 Digital Outputs	Modbus RTU, Bluetooth
M4M 20 ETHERNET	2 Digital Outputs	Modbus TCP/IP, Bluetooth
M4M 20-M ETHERNET	2 Digital Outputs	Modbus TCP/IP, Bluetooth
M4M 20 PROFIBUS	2 Digital Outputs	Profibus DP-V0, Bluetooth
M4M 20 I/O	2 Programmable I/O 2 Digital Outputs 2 Analog Outputs	Modbus RTU, Bluetooth
M4M 20 ROGOWSKI	2 Digital Outputs	Modbus RTU, Bluetooth
M4M 20 BACNET	2 Digital Outputs	BACnet/IP, Bluetooth

### 3.5. Overall dimensions

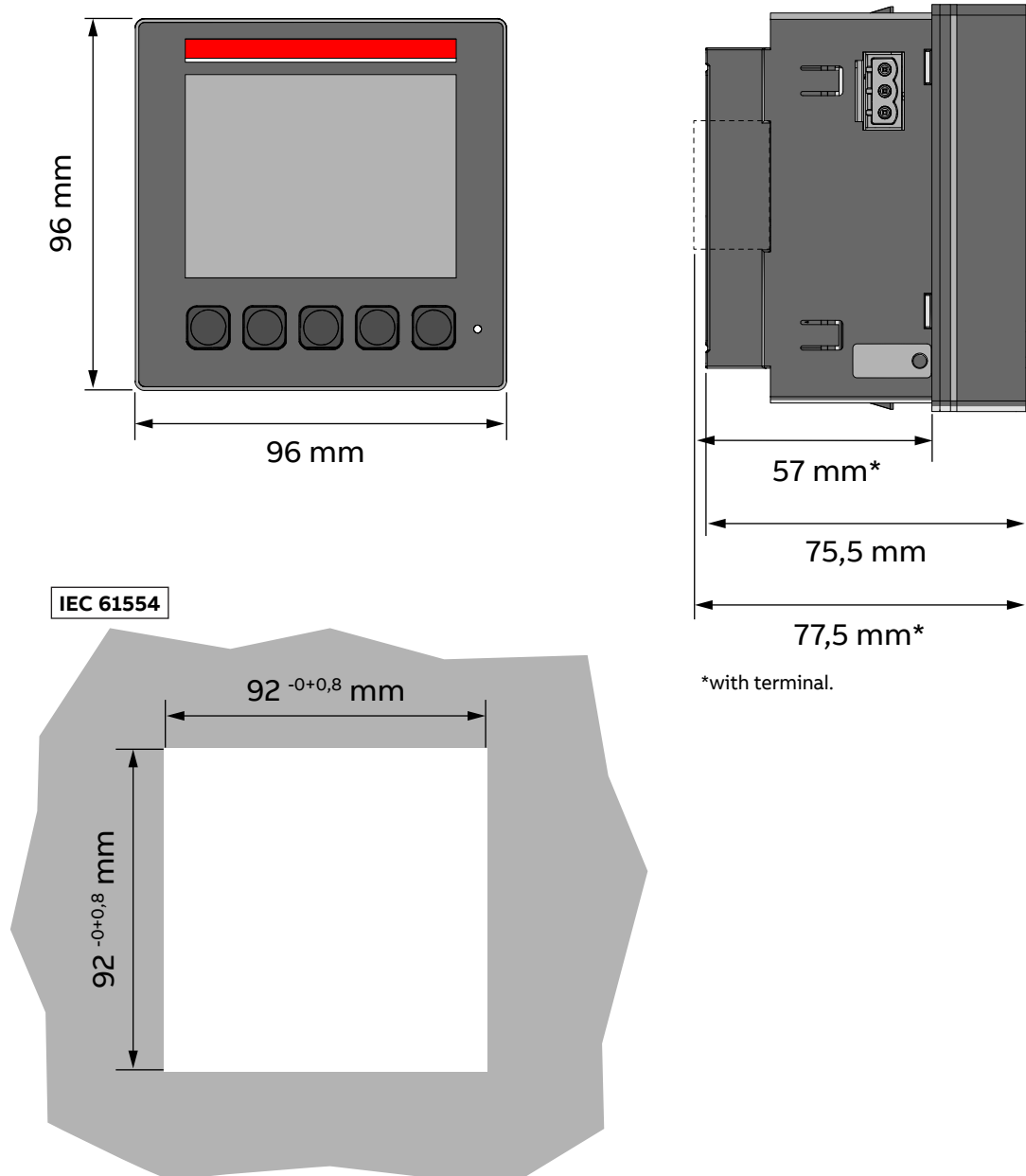

### 3.6. Technical data

<b>Auxiliary power supply</b>		
Voltage range	[V]	48 to 240 VAC/VDC $\pm 15\%$
Frequency	[Hz]	50/60 Hz $\pm 5\%$
Power consumption	[VA]	10 VA max
Installation category		CAT III 300V class per IEC 61010-1 edition 3
Protection fuse		T1 A - 277 VAC
<b>Measurement accuracy</b>		
Measurement type		True RMS up to the 40th harmonic 128 samples per cycle, zero blind
IEC 61557-12		IEC 61557-12 PMD/S/K70/0,5
Active energy		Class 0,5 acc. to IEC 61557-12 Class 0,5S acc. to IEC 62053-22
Reactive energy		Class 2 acc. to IEC 61557-12 Class 2S acc. to IEC 62053-23
Active power		Class 0,5 acc. to IEC 61557-12
Reactive power		Class 2 acc. to IEC 61557-12
Apparent power		Class 0,5 acc. to IEC 61557-12
Voltage		Class 0,2 acc. to IEC 61557-12
Current		Class 0,2 acc. to IEC 61557-12
Neutral current		Calculated
Frequency		Class 0,1 acc. to IEC 61557-12
Unbalances		Class 0,2 acc. to IEC 61557-12
Harmonics, THD (Current, voltage)		Class 1 acc. to IEC 61557-12
Analog Output		$\pm 2\%$ accuracy rate*
<b>Voltage measurement inputs</b>		
Measurement range	[V]	46(80)...480(830) V
Measurement category		400V~ (CAT III)
Rated frequency	[Hz]	50-60 Hz
Max. VT secondary (indirect connection)	[V]	400 VAC (L-N)
Max over voltage	[V]	800 VAC (L-L)
Protection fuse	[V]	T1 A - 277 VAC

The M4M voltage inputs have a high impedance which decreases power consumption and increases security due low current flow in the voltage input circuit. However, if the voltage input wirings are floating, i.e. not connected to a voltage source, the wires may work as an antenna to the surroundings electric fields which can create a perceived floating voltage. The M4M will not show this floating voltage in case it is below 40V (below the Voltage measurement range) and in case of a three phase system with measuring current below starting current (below current measurement range). In all other cases of floating voltage the M4M display may show a voltage bigger than zero, which depends on installation conditions. This behavior does not affect the reliability of the M4M in normal conditions with a connected load.

\*The total accuracy rate returned in the output of the Analog Output is equal to the sum of the Analog Output accuracy rate and the device accuracy rate.

<b>Current measurement inputs</b>	
Number of current inputs	3 (L1, L2, L3)
<b>Indirect insertion with CT</b>	
CT secondary	5 A (Class 0.5S)
	1 A (Class 0,5S)
Measurement range without accuracy derating	50 mA - 6 A
Starting current	1 mA
Burden	0.024 VA at 6 A
<b>Indirect insertion with Rogowski coils</b>	
	(only M4M 20 Rogowski)
Rated current	10000 A
Measurement range without accuracy derating	100 A - 12 kA
Starting current	10 A
<b>I/O</b>	
<b>Digital Output</b>	
Voltage (min - max)	5 - 240 VAC/DC
Current (min - max)	2 - 100 mA
Max ON state drop voltage	1,5 V
Max R value at Min voltage conditions (5 V)	1750 Ohm
Min R value at Max voltage conditions (240 V)	2400 Ohm
Pulse duration	[ms] 20 ms ON, 20 ms OFF
Pulse frequency	25 Hz
Alarm activation delay	[s] 1 - 900 s (programmable)
Alarm return hysteresis	0 - 40% (programmable)
<b>Digital Input</b>	
Maximum Voltage	240 VAC/DC
Max voltage for OFF state on input	20 VAC/DC
Min voltage for ON state on input	45 VAC/DC

**M4M 20-M (MID):** The Digital Output 1 of the M4M 20-M Modbus and M4M 20-M Ethernet is assigned as Pulse Output, associated to the active energy measured value.

<b>Analogue Output</b>	
Programmable electrical parameters	Span [0 - 20 mA or 4 - 20 mA]
Load	Typical 250 Ohm, max 500 Ohm
<b>Mechanical characteristics</b>	
Overall dimensions	96 mm x 96 mm x 77,5 mm (Depth inside the switchboard: 57mm )
IP degree of protection (IEC 60529)	Front: IP54 Terminals: IP20
Weight	[g] 400
<b>Terminal characteristics</b>	
Tightening torque	0,4 Nm
Voltage inputs	Nominal cross section: 2,5 mm <sup>2</sup> Solid/stranded wire: 0,2 - 2,5 mm <sup>2</sup> (AWG 24 - 12) Pitch: 7,62 mm Poles: 4
Current inputs	Nominal cross section: 2,5 mm <sup>2</sup> Solid/stranded wire: 0,2 - 2,5 mm <sup>2</sup> (AWG 24 - 12) Pitch: 5,08 mm Poles: 6 Screw flanges for fixing
RS-485 Serial port	Nominal cross section: 2,5 mm <sup>2</sup> Solid/stranded wire: 0,2 - 2,5 mm <sup>2</sup> (AWG 24 - 12) Pitch: 5,08 mm Poles: 3
I/O	Nominal cross section: 2,5 mm <sup>2</sup> Solid/stranded wire: 0,2 - 2,5 mm <sup>2</sup> (AWG 24 - 12) Pitch: 5,08 mm Poles: 3 (Programmable I/O, only on M4M 20 I/O) Poles: 3 (Digital outputs) Poles: 3 (Analog outputs, only on M4M 20 I/O)
Rogowski current probes	Only with ABB Rogowski probes: - R4M-200: 200 mm diameter (2CSG202150R1101) - R4M-80: 80 mm diameter (2CSG202160R1101)

<b>Climatic conditions</b>	
Operating temperature	-25 to 70 °C (K70 acc. to IEC 61557-12)
Storage temperature	-40 to 85 °C (K70 acc. to IEC 61557-12)
Relative humidity	Max 93% (non-condensing) at 40°C
Pollution degree	2
Altitude	< 2000 m
Mounting requirement	Only for internal usage
<b>User Interface</b>	
Access to device	5 pushbuttons
Display type	Graphic color display
Display dimensions	70 x 52 mm (3.5")
<b>Communication protocol</b>	
<b>Modbus RTU</b>	<b>M4M 20 Modbus, M4M 20 I/O, M4M 20 Rogowski, M4M 20-M Modbus</b>
Communication interface	RS485 with optical isolation
Baud rate	9.6, 19.2, 38.4, 57.6, 115.2 kbps
Parity number	Odd, Even, None
Stop bit	1, 2
Address	1-247
Connector	3 pole terminal
<b>Profibus DP-V0</b>	<b>M4M 20 Profibus</b>
Protocol	Profibus with slave DP-V0 function in compliance with IEC 61158 regulations
Communication interface	RS485 with optical isolation
Baud rate	Automatic detection [9.6k - 12 Mbps]
Address	0-126
Connector	DB 9 female connector (do not use connectors with 90° cable outlet)
LED indicators	Green for communication status Red for communication error
<b>Modbus TCP/IP</b>	<b>M4M 20 Ethernet, M4M 20-M Ethernet</b>
Protocol	Modbus TCP/IP
Communication interface	RJ45
<b>BACnet</b>	<b>M4M 20 Bacnet</b>
Protocol	BACnet/IP
Communication interface	RJ45
<b>Bluetooth</b>	
Type	BLE (Bluetooth Low Energy)
<b>Standards</b>	
Power metering and monitoring devices (PMD)	IEC 61557-12 (IEC 62053-22, IEC 62053-23)
Electrical safety	IEC 61010-1
EMC	IEC 61326-1 (IEC 61000-3-2, IEC 61000-3-3, IEC 61000-4-2, IEC 61000-4-3, IEC 61000-4-4, IEC 61000-4-5, IEC 61000-4-6, IEC 61000-4-8, IEC 61000-4-11)

**Technical data for M4M 20-M according to the Measuring Directive 2014/32/EU**

MID standards	EN 50470-1 EN 50470-3
Voltage measurement (type of network and rated voltage)	3Ph/4W/3CT 3Ph/3W/2CT 1Ph/2W/1CT 3 x 230 (400)...3 x 400 (690) V
Current rating (I min- I ref(I <sub>max</sub> ))	0,01-1(6) A
Rated frequencies, tolerance	50 Hz and 60 Hz, +/- 2%
Active Energy accuracy class	Class C
Electromagnetic ambient conditions	Class E2
Mechanical ambient conditions	Class M1
LED indicator pulse frequency	200000 imp/kWh
LED indicator pulse length	1ms

---

## 4. Measurement method

Import energy registers increments when the power is positive and export energy registers increments when power is negative.

All import and export registers are positive (or zero) and will either increment or stand still. Net energy registers contains the import minus the export register for corresponding registers and can be positive or negative.

The ABB M4Ms use the vector registration method for computation of energy.

---

### 4.1. Vector registration method

In the vector registration method the instantaneous energy consumption of the measuring elements (the three phases in 3-phase 4-wire metering) is summed up to the total register. If the sum is positive the import register is incremented and if the sum is negative the export register is incremented.

Say for example that the power in the three phases are L1: +1 kW, L2: -1 kW and L3: +1 kW. The total power will then be  $1 - 1 + 1 = 1$  kW and the total import register will increase at a rate of 1 kWh each hour and the total export register will stand still.

If the power in the three phases instead are L1: +1 kW, L2: -1 kW and L3: -1 kW the total power will be  $1 - 1 - 1 = -1$  kW and the total export register will increase with the rate of 1 kWh each hour and the total import register will stand still.

Note that if a 3-phase load with neutral have connections between the phases that have a power factor smaller than 0.5, that is constitute a mainly reactive load, the power in single phases can be negative even if the 3-phase load is consuming energy. The total power and energy will however always be positive for a 3-phase load that is consuming energy.

Note also that the sum of the per phase registers will be bigger than the total register if the power in the phases contains a mix of both positive and negative power. In applications where the load is a 3-phase load the total register should always be used for billing.

# 5. Installation

## 5.1. Assembly M4M 20

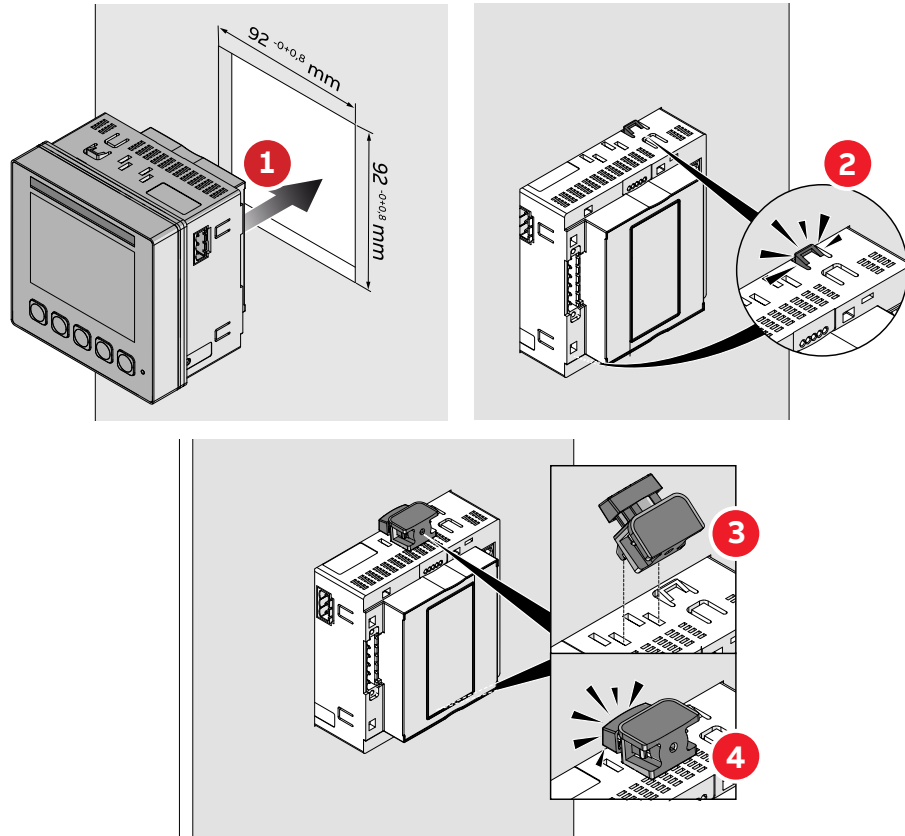

### Sealing of terminal block for M4M 20-M (MID)



**M4M 20-M (MID):** In order to ensure antitampering for MID directive, sealing of terminal block is mandatory

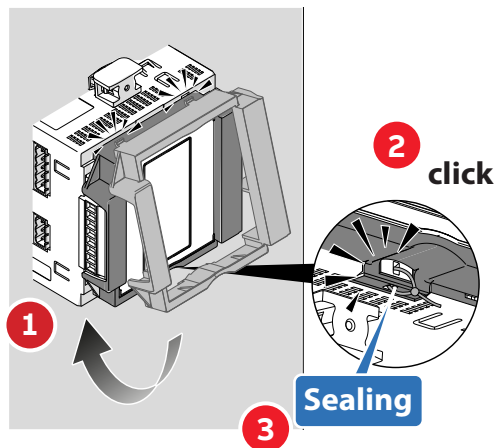

## 5.2. Disassembly M4M 20

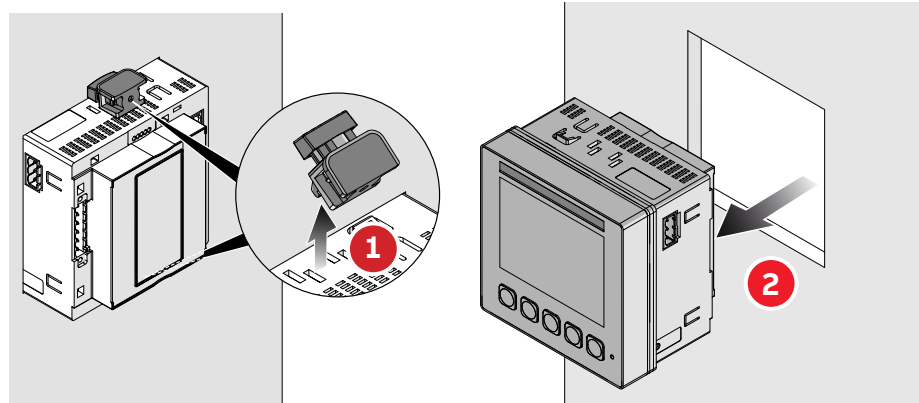

## 5.3. Disassembly M4M 20:

In order to remove the terminal block, please use a screwdriver in the dedicated area and turn it.

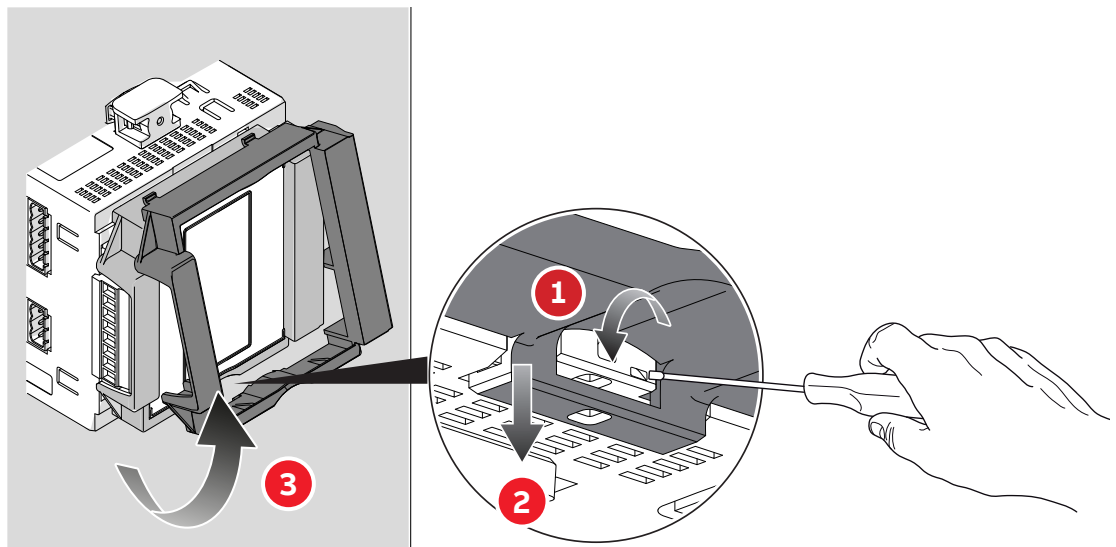

Please notice that if seal is broken, tampering of M4M for MID will happen!

### 5.4.Wiring diagrams

The operations to carry out for the correct connection of the device, based on the type of electric line available, are described in this section.



The installation and the cabling of the device must be carried out by qualified personnel.



Danger of electrocution, burning and electric arc. Use the personal protection devices suitable to adhere to the current regulations governing electrical safety. Prior to carrying out any connections check the sectioning of the electric supply with the voltage detection device.

- M4M 20 connection

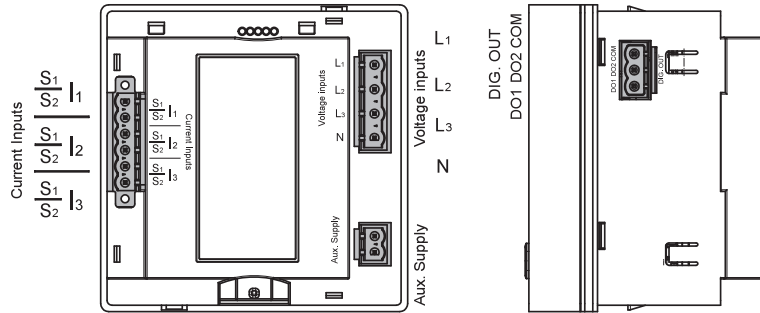

- M4M 20 MODBUS connection  
M4M 20-M MODBUS connection

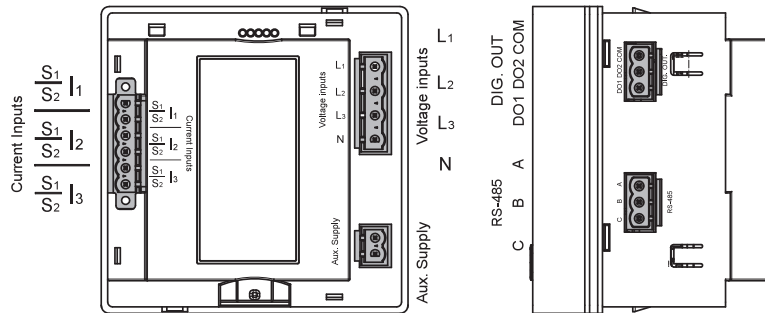

- M4M 20 ETHERNET connection  
M4M 20-M ETHERNET connection

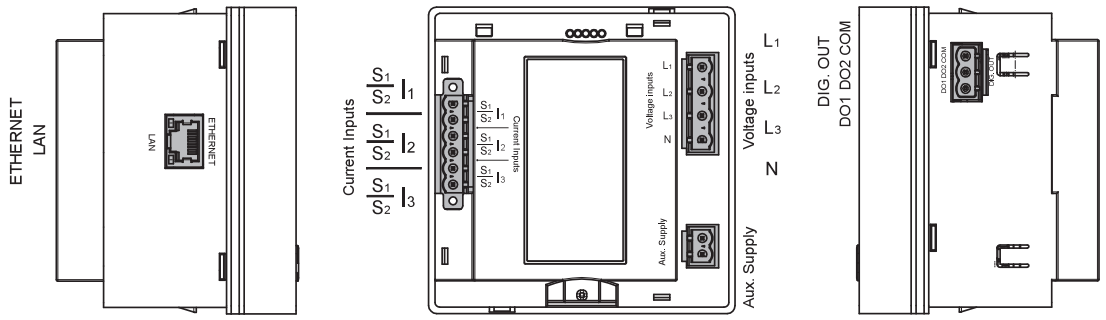

- M4M 20 PROFIBUS connection

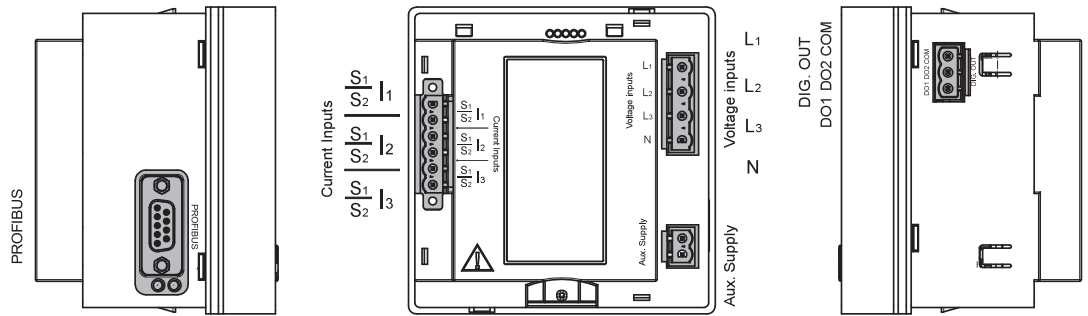

- M4M 20 I/O connection

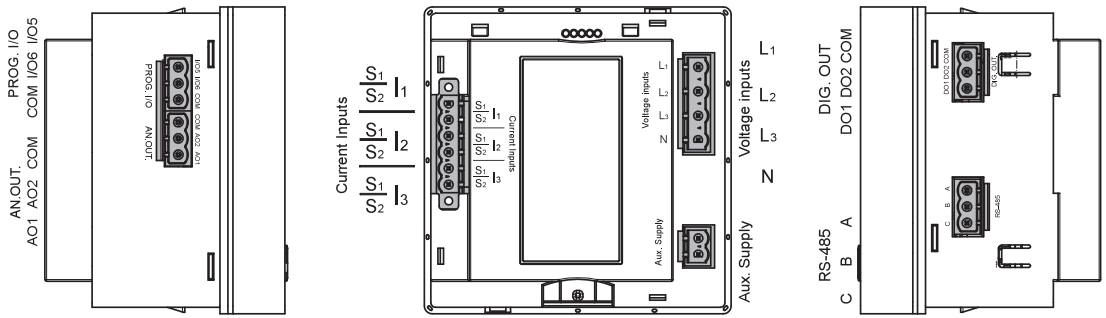

- M4M 20 ROGOWSKI connection

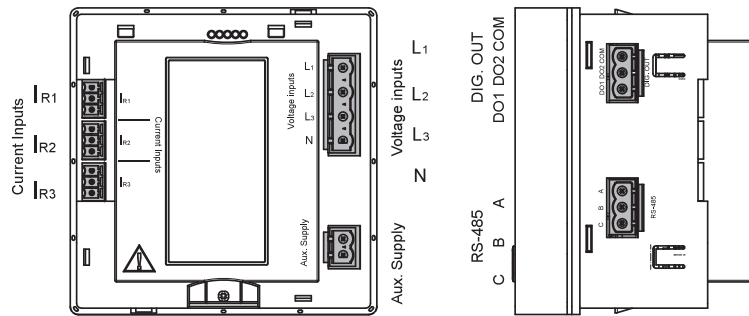

- M4M 20 BACNET connection

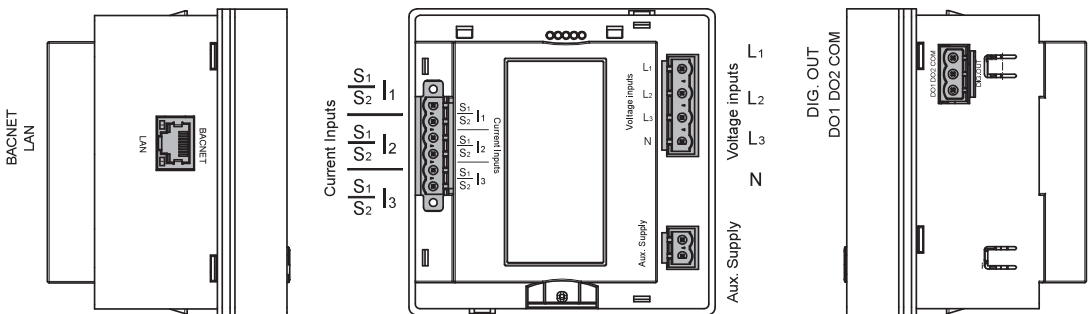

**Wiring diagrams - M4M 20, M4M 20 Modbus, M4M 20 Ethernet, M4M 20 I/O, M4M 20 Profibus, M4M 20 Bacnet, M4M 20-M Modbus, M4M 20-M Ethernet**

The M4M 20 can be used on different type of network (please refer to chapter “7.First commissioning” for the configuration on the device).

According to the type of network that has been chosen, the parameters visualized on the device HMI change.

Below the wiring diagrams for M4M 20 working with CT .../5A or .../1A (M4M 20, M4M 20 Modbus, M4M 20 Ethernet, M4M 20 I/O, M4M 20 Profibus, M4M 20 Bacnet, M4M 20-M Modbus, M4M 20-M Ethernet) are shown:

- 3-phase 4-wire network with 3CTs ok for MID on N4M 20-M

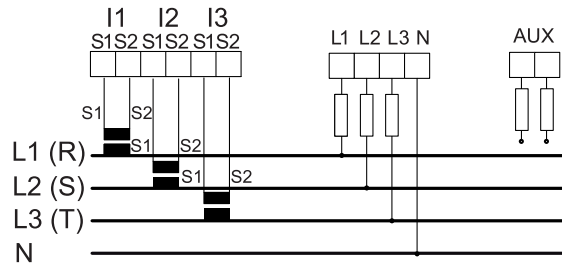

- 3-phase 4-wire network with 1CT

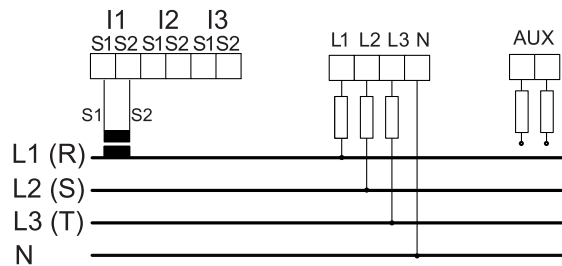

- 3-phase 3-wire network with 1CT

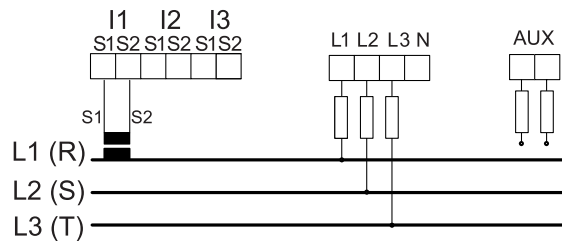

- 3-phase 3-wire network with 3CTs

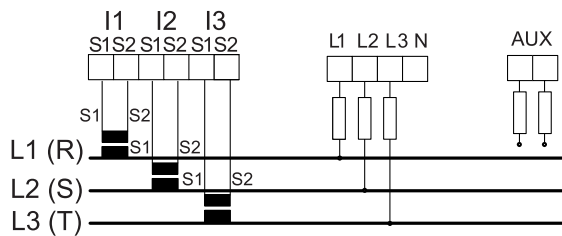

- 3-phase 3-wire network with 2CTs ok for MID on N4M 20-M

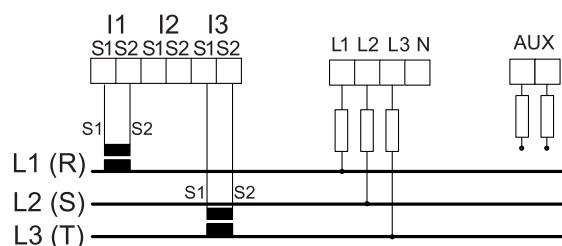

- 2-phase 3 wire network with 2CTs

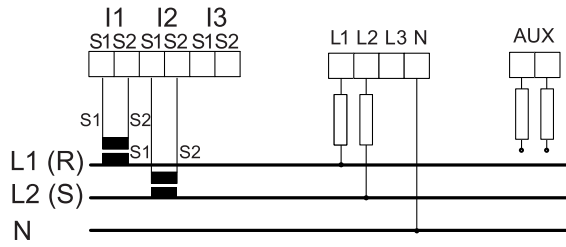

- 1-phase 2 wire network with 1CT ok for MID on N4M 20-M

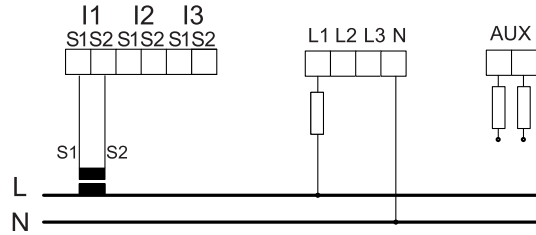

- 3-phase 3-wire 3-CTs + 3VTs

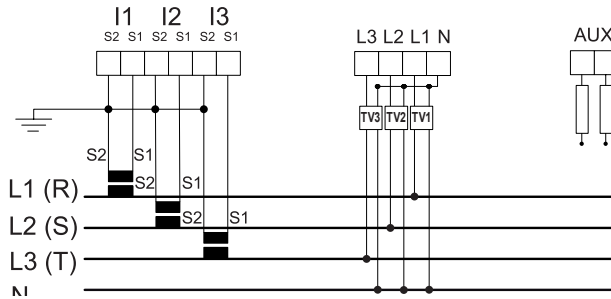

**M4M 20-M (MID):** In order to ensure antitampering for MID directive, only MID compliant wiring have to be selected and sealing of terminal block is mandatory.

**Wiring diagrams - M4M 20 Rogowski**

Below the wiring diagrams for M4M 20 working with Rogowski coils (M4M 20 Rogowski) are shown:

- 3-phase 4-wire network with 3RogCTs

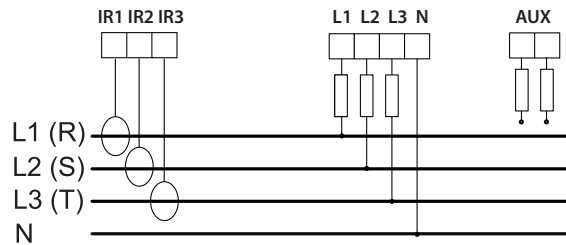

- 3-phase 4-wire network with 1RogCT

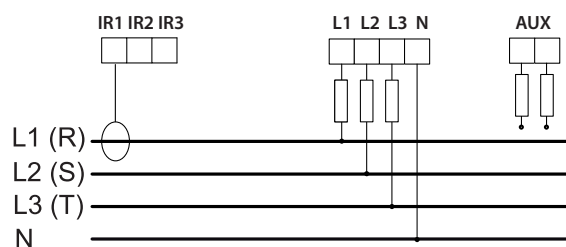

- 3-phase 3-wire network with 1RogCT

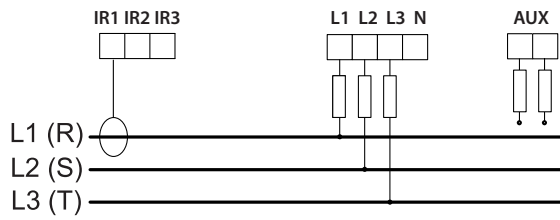

- 3-phase 3-wire network with 3RogCTs

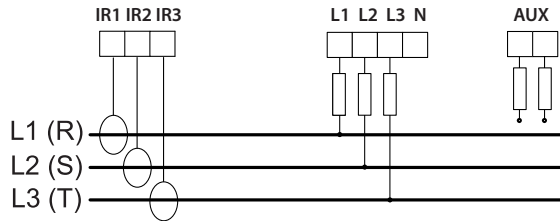

- 3-phase 3-wire network with 2RogCTs

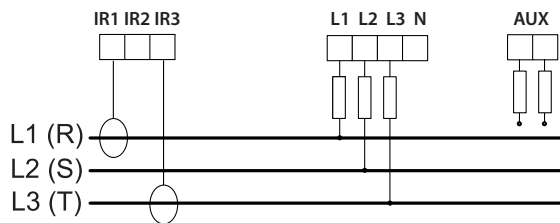

- 2-phase 3-wire network with 2RogCTs

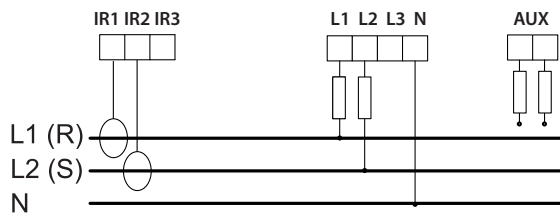

- 1-phase 2-wire network with 1RogCT

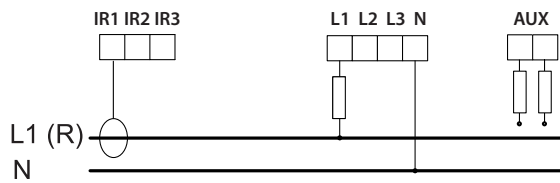

**Inputs and outputs connections**

- Digital outputs: Alarm output with external relays for load command. Example of wiring for DO1 as alarm output COM is common for all Digital outputs:

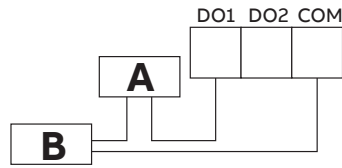

**A:** V aux 48 V a.c./d.c. 100mA  
**B:** External relay

- Digital outputs: Pulse output. Example of wiring for DO1 as pulse output COM is common for all Digital outputs:

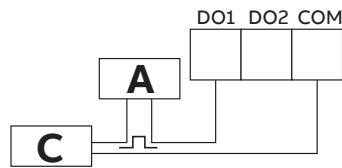

**A:** V aux 48 V a.c./d.c. 100mA  
**C:** Pulse acquisition

- Digital outputs: Alarm output with external relays for load command (available only on M4M 20 I/O). Example of wiring for I/O5 as alarm output COM is common for all Digital outputs:

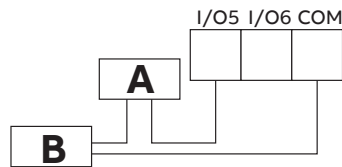

**A:** V aux 48 V a.c./d.c. 100mA  
**B:** External relay

- Programmable I/O: Pulse output (available only on M4M 20 I/O). Example of wiring for I/O5 as pulse output COM is common for all Digital outputs:

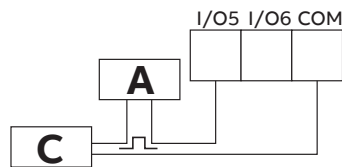

**A:** V aux 48 V a.c./d.c. 100mA  
**C:** Pulse acquisition

- Programmable I/O: Pulse input for external pulse acquisition (available only on M4M 20 I/O):

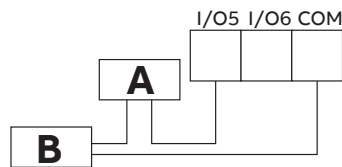

**A:** 24-240VDC / 57-240VAC  
**B:** Pulse acquisition (Impulse length at least 30 mS)

- Analog outputs, typical load 250 Ohm, max 500 Ohm (available only on M4M 20 I/O):

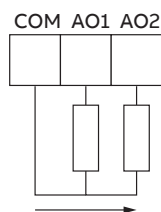

## 6. Access to device





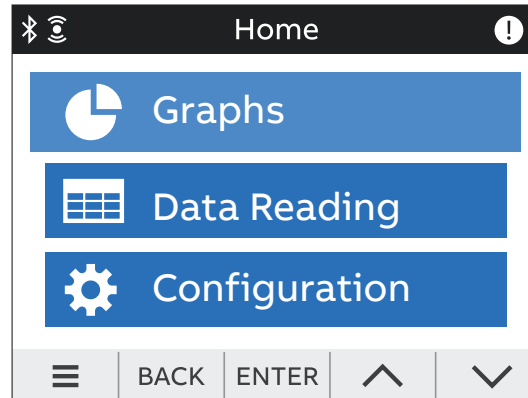







### 6.1. Homepage

The device menu is divided into three sections.





Menu	Description
Graphs	Graphical representation of the main parameters.
Data reading	Values of the main parameters.
Configuration	Setup of the device.

## 6.2. Navigation symbols

Symbol	Description
	Shortcut key with 3 sections: Notifications, Favourite page and Home.
	Return to the previous page.
	Confirm the selection.
	Increase or decrease the value. Keeping pressed will increase the speed of the number variation.
	Move cursor up or down.
	Move to previous or next page.
	Bluetooth connectivity.
	Notifications.
	Favourite page.
	Home.
	Configuration mode is protected (needed to enter password).
	Configuration mode is unprotected (password already entered).

## 6.3. Notification icons

Symbol	Description
	Alarms: user settable (related to specific parameters, threshold, etc).
	Warnings: related to installation conditions and device settings.
	Errors: related to the device and to self-diagnostics in general.

## 6.4. Overview of menu displays

Each section of the device contains different menus and submenus as per below tables:



Menu	Description
Realtime Graphs	Bargraphs for voltage (L-N, L-L), current, power (active, reactive, apparent).



Menu	Description
Realtime	Summary, voltage (L-N, L-L), current, power (active, reactive, apparent), frequency.
Energy	Active, reactive, apparent energy, import, export and net.
Power quality	THD (voltage, current), unbalances (voltage, current), power factor and cosphi per each phase.
Average	Average values in the latest period for voltage, current power (active, reactive, apparent).
Min value	Minimum values for voltage, current and demand power (active, reactive, apparent).
Max value	Maximum values for voltage, current and demand power (active, reactive, apparent).
I/O	I/O status according to the I/O type and M4M version.
Notifications	List of notifications divided into alarms, warnings, errors.
Timers	Count-up timer (on hours), count-down timer (maintenance timer).



Menu	Description
Unit	Settings related to the device itself.
Installation	Settings related to the installation conditions.
I/O	Definition of I/O type of the M4M version.
Alarms	Definition of alarm conditions to be visualized as notifications or linked to I/O.
Communication	Settings related to the embedded communication protocols of the M4M version
Other settings	Settings for average values, timers, energy conversion

### 6.5.Data entry

For the configuration it is possible either to choose from a list of values or to manually enter a value.

#### List of values

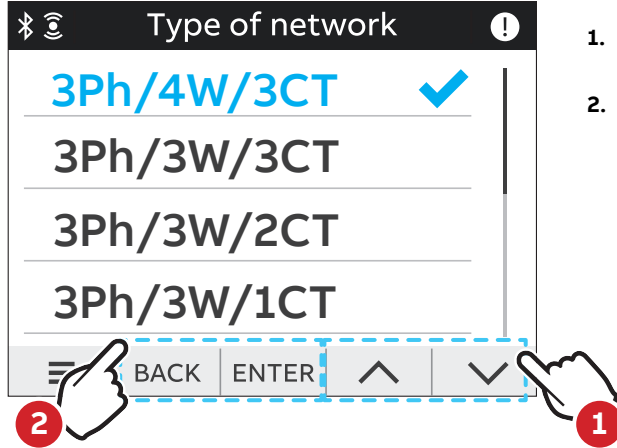

1. Use   to scroll the list on of values or fields.
2. Press  to confirm or  to cancel the modification.

#### Manual data entry

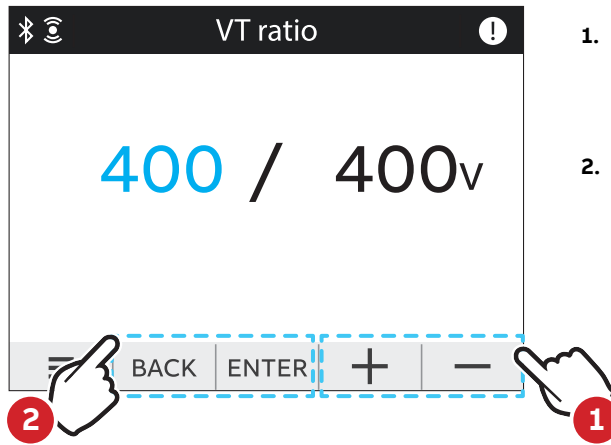

1. Use   to scroll the numerical characters available in either ascending or descending order until the required character is obtained;
2. Press  to confirm or  to cancel the modification.

Keeping pressed   will increase the speed of the number variation.





## 6.6.Favourite page

It is possible set a page as a **Favourite page**, that is then easily accessible by clicking the **Favourite** key.

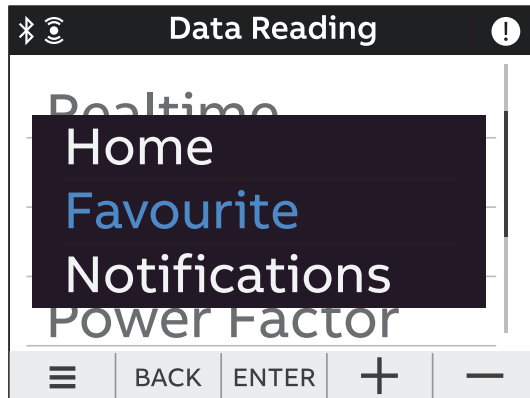
### Setting - Favourite page





**M4M 20-M (MID):** It is not possible to set a **Favourite page**, after stand-by time the menu go back to a meter summary screen with active import and export energy.

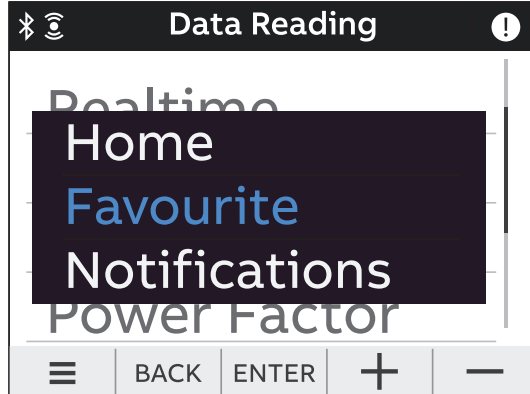

1. Enter the page you would like to set as favourite
2. Select  Shortcut key.
3. With   select the menu item Favourite page
4. Hold on  for 3 seconds;
5. When the configuration is completed, the green pop-up bar **Operation succeeded** will appear.

### Display Favorite page



1. Enter the page you would like to set as favourite
2. Select  Shortcut key.
3. With   select the menu item Favourite page
4. Hold on  ;
5. When the configuration is completed, the green pop-up bar **Operation succeeded** will appear.

To reset the **Favourite page** follow above steps when inside Homepage.  
 Only the pages from Graphs and Data Reading menus can be set as favourite.  
 Menu list pages cannot be set as favourite page.

## 7. First commissioning

At first power up of M4M network analyzers, wizard procedure will guide the user in the first commissioning steps:

1. Set the language (please refer to chapter “7.1.Setting language”)
2. Set a password (please refer to chapter “7.2.Password for the first use”)
3. Set the date and time on the device (please refer to chapter “7.3.Date and time”)
4. Set the type of network (please refer to chapter “7.4.Type of network”)
5. Set the CT ratio (please refer to chapter “7.5.CT ratio”)
6. Set the VT ratio (please refer to chapter “7.6.VT ratio”)
7. M4M 20-M (MID): Set the Lock (please refer to chapter “7.7.Lock MID version”)

### 7.1. Setting language

It is possible to change the display language to one of the languages present in the device.



1. Use   to scroll the list on of values or fields.
2. Press  to confirm or  to cancel the modification.

### 7.2. Password for the first use

A password can be set by the user to protect the Configuration menu and avoid any unwanted modification to the device settings.

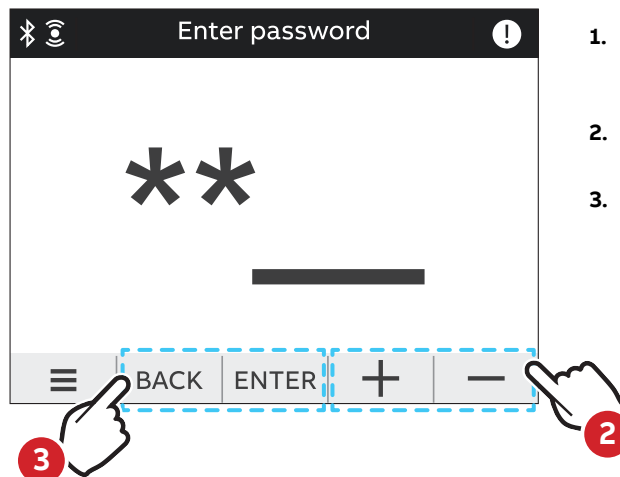

1. At the first use it is mandatory to define a password. The password is composed by 5 numerical characters.
2. In order to select each numerical character, it is necessary to use  .
3. Press  to confirm or  to cancel the modification.

In order to disable the password, please set the new password as 00000.

The password can be changed in any moment in Configurations -> Unit -> Modify password (please refer to chapter “8.1.Unit”).

**M4M 20-M (MID):** It is not possible to disable password. Password only protects non-critical configurations. Critical configurations are protected by Lock (please refer to chapter “7.7.Lock MID version”)

### 7.3. Date and time

Setting date and time is mandatory in order to use the time-related functionalities on the device (e.g. Maximum, Minimum). Please notice that if no date and time are set, no timestamp will be available on the measured data.

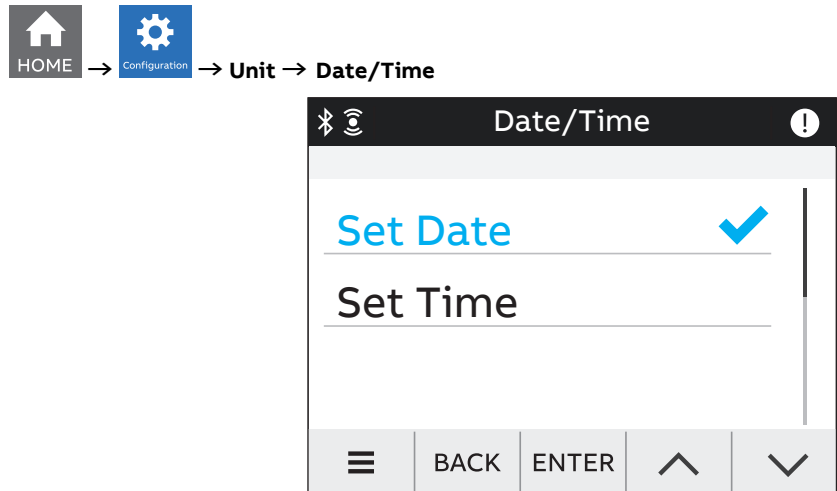

Menu	Description
Set date	Configure the current date with format YYYY/MM/DD.
Set time	Configure the current time.



When M4M 20 is turned off, the date and time are reset. After turning on the M4M 20 network analyzer, please configure date and time.

### 7.4. Type of network

In order to configure the type of network it is needed to choose one of the available options according to the installation conditions.

MID compliant networks are market with M on the display.

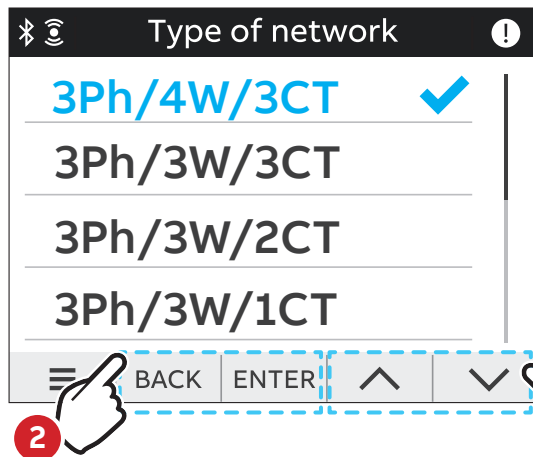

1. Use   to scroll the list on of values or fields.
2. Press  to confirm or  to cancel the modification.

According to the type of network that has been chosen, the parameters visualized on the device HMI change. Please see below the table with details:

Option	Description	Option	Description
3Ph/4W/3CT	3-phase 4-wire + 3CTs	3Ph/3W/2CT	3-phase 3-wire + 2CTs
3Ph/4W/1CT	3-phase 4-wire + 1CT	2Ph/3W/2CT	2-phase 3-wire + 2CTs
3Ph/3W/1CT	3-phase 3-wire + 1CT	1Ph/2W/1CT	1-phase 2-wire + 1CT
3Ph/3W/3CT	3-phase 3-wire + 3CTs		

### 7.5.CT ratio

M4M is capable to measure current only via indirect connection by means of current transformers CTs .../5A or .../1A (M4M 20, M4M 20 Modbus, M4M 20 Ethernet, M4M 20 I/O, M4M 20 Profibus, M4M 20 Bacnet, M4M 20-M Modbus, M4M 20-M Ethernet) , or Rogowski coils (M4M 20 Rogowski)..

If CTs are used, then on the network analyzer it is needed to set the transformation ratio of the installed current transformers.

If Rogowski coils are used (M4M 20 Rogowski), it is not needed to set any transformation ratio.

In order to configure the current transformers ratio it is possible either to choose the values from a list of values (default settings) or to manually enter a value.

#### Settings - choose CT ratio

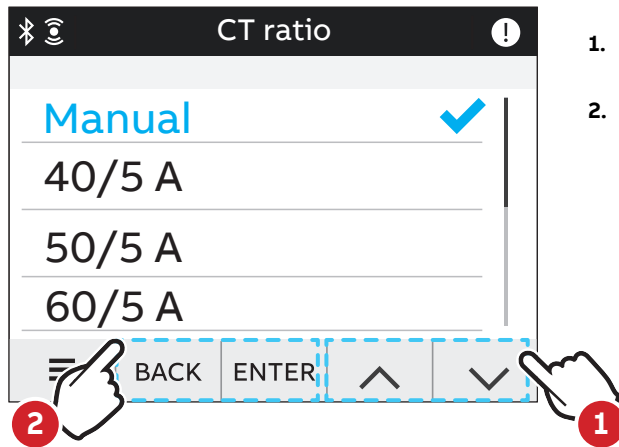

1. Use   to scroll the list on of values or fields.
2. Press  to confirm or  to cancel the modification.

Default values of CT ratio	Default values of CT ratio
40/5	200/5
50/5	250/5
60/5	400/5
80/5	600/5
100/5	800/5
150/5	1000/5

## CT ratio - Manual data entry

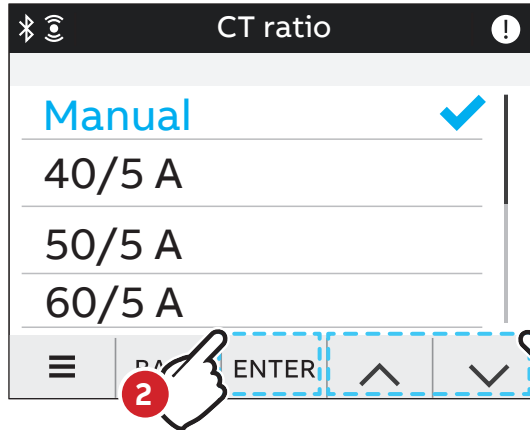

1. Use   to Select the option "Manual".
2. Press  to confirm.

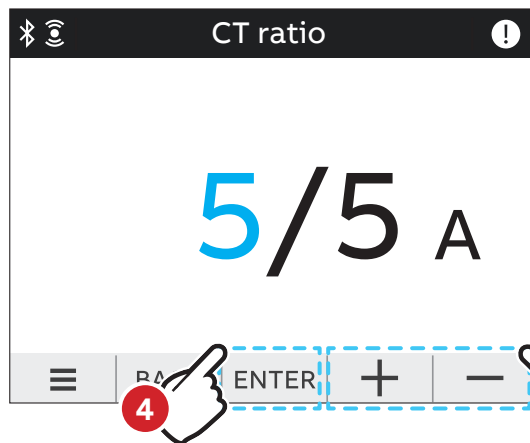

3. Enter the value of the primary with  .
4. Press  to confirm.



Max primary CT: 50.000

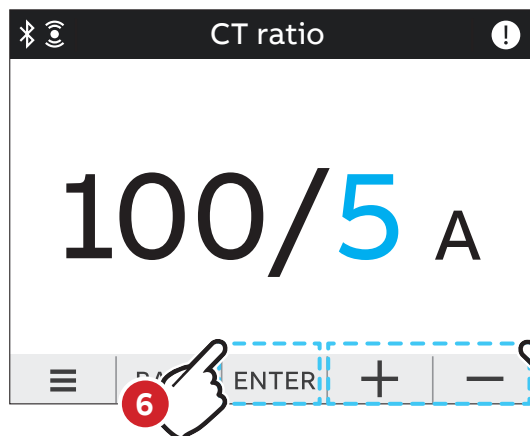

5. Enter the value of the secondary with  .
6. Press  to confirm.

If the CT is replaced varying the value of the transformation ratio, before proceeding we recommend:

1. Note down the value of the energy counts accumulated with the previous ratio.
2. Reset the energy counts.
3. Insert a new value of the transformation ratio.

Enter the password if necessary.

Please notice that if M4M 20 Rogowski is being used, no CT ratio has to be set for Rogowski coils.

Primary of CT has to be higher than the secondary.

### 7.6.VT ratio

M4M is capable to measure voltage via direct connection up to 400 VL-N (690V L-L), or via indirect connection by means of voltage transformers.

In order to configure the voltage transformer ratio it is needed to enter manually the values of both primary and secondary. The default values are 400 for the primary and 400 for the secondary.

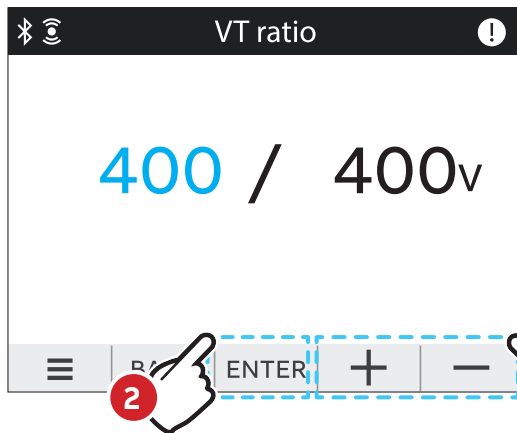

- 1. Enter the value of the primary with
- 2. Press  to confirm.

 Max primary VT: 500.000  
Max secondary VT: 999

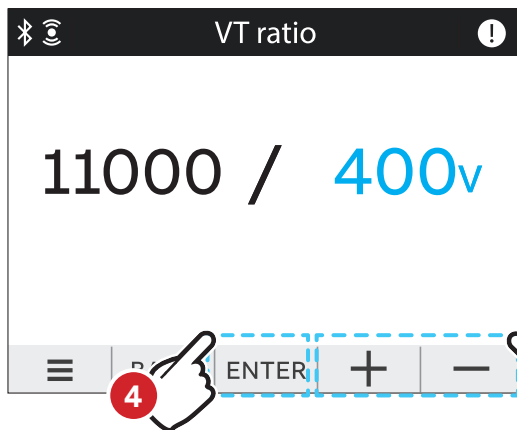

- 3. Enter the value of the primary with
- 4. Press  to confirm.

Enter the password if necessary.

In case of direct insertion, up to 500V phase-neutral, without voltage transformers set 100/100 (default) as value.

---

## 7.7.Lock MID version

At the end of the “7.First commissioning” phase the lock operation is required. It can be set once and the user cannot reset the lock state.



M4M 20-M will not count any MID energy until it is locked.

### M4M 20-M (MID) only

Following parameters, set during first commissioning phase, **cannot be modified after the lock operation.**

- Primary current transformer
- Secondary current transformer
- Primary voltage transformer
- Secondary voltage transformer
- Type of network settings

## 8. Configuration

In order to change any configuration of the device, it is mandatory to enter the password. The password is valid as soon as the user remains in the Configuration section and for max. 10 minutes. After quitting the Configuration section, it is needed to enter again the password.

If the padlock icon is closed, it is needed to enter the password in order to modify any configuration. If the padlock icon is open, it is possible to modify any configuration without entering any password.

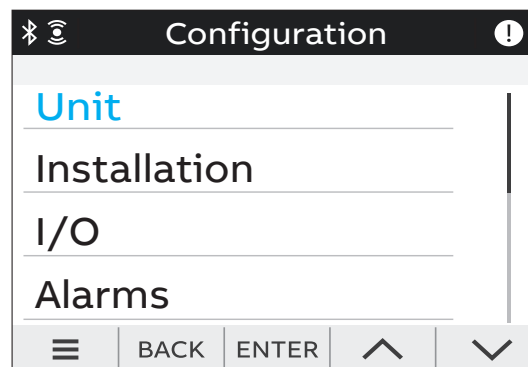

Press  key in order to return to homepage.

If the user exits from the Configuration section, the device configuration is protected again and it is needed to re-enter the password.

### 8.1. Unit

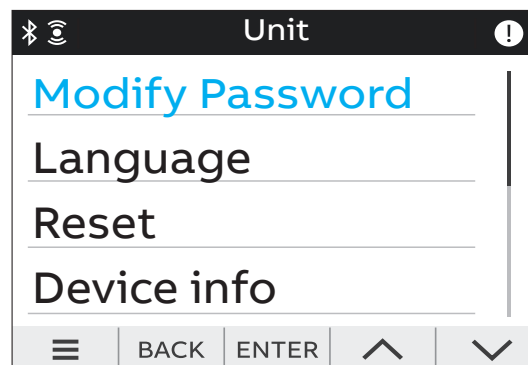

Menu	Description
Modify Password	Change the existing password.
Language	Change the language of the display.
Reset	Reset options for the meter.
Device info	Visualization of info related to the meter.
Date/Time	Change date and time on the device.
Brightness	Change the brightness of the display.
Energy Saving	Set energy saving mode for the display.
Audit log	Visualization of audit log and system log.

## Modify password menu

In order to modify the password:

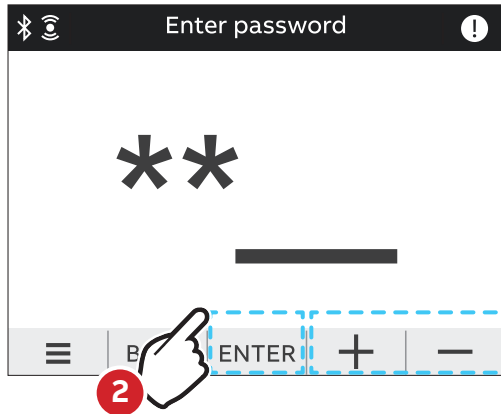
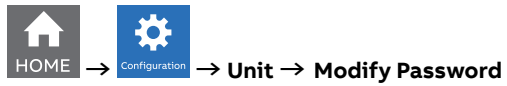

1. Enter the current password. In order to select each numerical character, it is necessary to use  .
2. Confirm the selection of all numerical characters with .

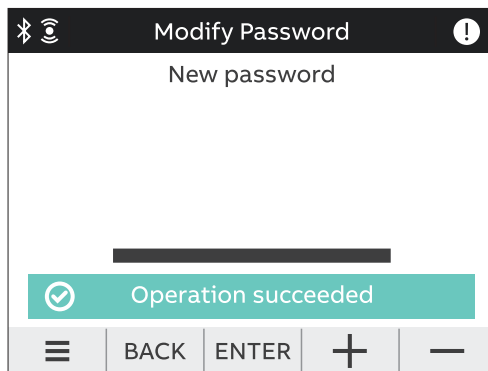

3. When the modification is completed the green popup bar **Operation succeeded** will appear.
4. Set the new password.
5. When the entry is completed the green popup bar **Operation succeeded** will appear.

If a Factory reset is carried out, also the password is reset to default.

### Language menu

It is possible to change the display language to one of the languages present in the device. (please refer to chapter “7.1.Setting language”).



### Reset menu

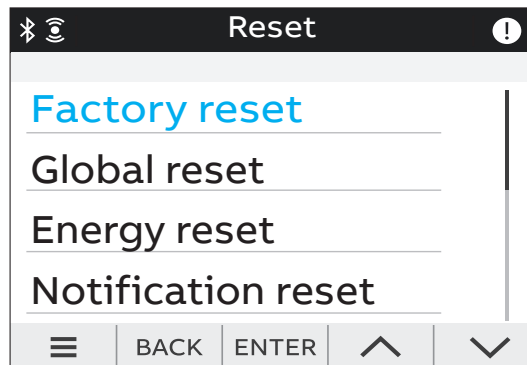
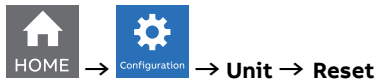

Type of reset	Description
Factory reset	Restore the device to the factory state except for the audit log. Up to 20 factory resets can be carried out over the product lifetime.
	<b>M4M 20-M (MID)</b> Factory reset doesn't reset following parameters: <ul style="list-style-type: none"> <li>• primary current transformer</li> <li>• secondary current transformer</li> <li>• primary voltage transformer</li> <li>• secondary voltage transformer</li> <li>• type of network settings</li> </ul>
Global reset	Complete reset of the device except for the settings and the audit log
Avg/Min/Max reset	Reset the average, min and max data.
Energy reset	Erase all energy measurement accumulators. Up to 240 energy resets can be carried out over the product lifetime.
	<b>M4M 20-M (MID)</b> Energy reset is disabled for MID version.
Notification reset	Erase all notifications (Alarms, Warnings, Errors).
Timer reset	Reset the count up counter to zero and the count down counter to the last set starting value

### Device Info menu

In this menu it is possible to visualize the main info related to the M4M network analyzer: FW version, FW CRC, product name and unique serial number.

It is highly recommended to update the firmware to the latest version for security and functionality reasons.

Please check the ABB website and download the latest version of the firmware.

In order to update the FW to the latest version (via Modbus RTU or Modbus TCP/IP) it is necessary to use ABB Software Ekip Connect 3.

### Date/Time menu

During the first commissioning, it is highly recommended to configure the date and time on the network analyzer (please refer to chapter “7.3.Date and time”).

### Brightness menu

In this menu it is possible to modify the display brightness during normal operation conditions.

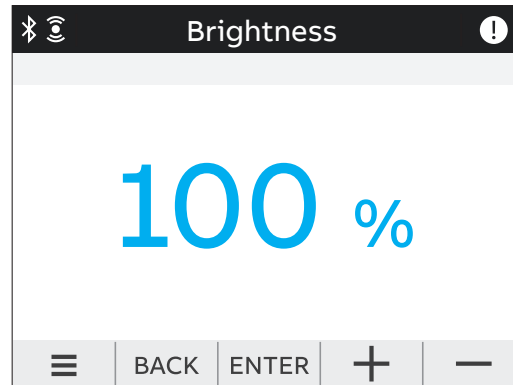
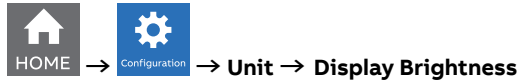

The default value is **100%** but it can differ from **10%** to **100%**.

The lifetime of the graphical display depends on its brightness and stand-by time. It is highly recommended to limit the brightness level of the display in order to ensure a longer lifetime of the device.

### Energy saving menu

In this menu it is possible to define the stand-by time and the stand-by brightness of the display in order to limit the device power consumption when not in operation conditions.

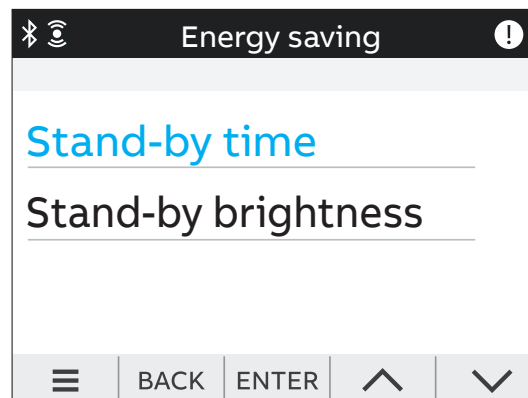
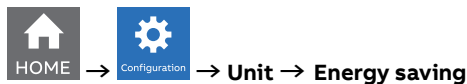

Menu	Description
Stand-by time	Set up the time after that the brightness decrease. The <b>default value is 3 minutes</b> but it can differ from 1 to 60 minutes.
Stand-by brightness	Set up the level of brightness when the device is in stand-by. The <b>default value is 40%</b> but it can differ from <b>0%</b> to <b>100%</b> .

The lifetime of the graphical display depends on the brightness of the display. It is highly recommended to limit the brightness level of the display in order to ensure a longer lifetime of the device.

### Audit log menu

The Audit Log stores an event after an attempt has been made to upgrade the firmware and/or CT ratio, VT ratio or Type of network is modified.



Each entry contains following data:

Menu	Description
System info	Where general information about device from the moment of entry creation is presented.
Configuration	Where snapshot of CT/VT ratios and Type of network just right after a successfully performed operation is presented.
Energy	Where value of total imported active energy, imported active energy of L1-L3 as well as total exported active energy from the moment of entry creation are presented.

Below you can find the detail of data present for each log entry:

<b>System info</b>	Entry num Timestamp Upgrade counter FW Version
<b>Configuration</b>	TRAF0_V_Prim TRAF0_V_Sec TRAF0_I_Prim TRAF0_I_Sec TRAF0_IN_Prim TRAF0_IN_Sec WIRES
<b>Energy</b>	ACTIVE_ENERGY_IMPORT_TOTAL ACTIVE_ENERGY_IMPORT_L1 ACTIVE_ENERGY_IMPORT_L2 ACTIVE_ENERGY_IMPORT_L3 ACTIVE_ENERGY_IMPORT_TAR1 ACTIVE_ENERGY_IMPORT_TAR2 ACTIVE_ENERGY_IMPORT_TAR3 ACTIVE_ENERGY_IMPORT_TAR4 ACTIVE_ENERGY_IMPORT_TAR5 ACTIVE_ENERGY_IMPORT_TAR6 ACTIVE_ENERGY_EXPORT_TOTAL

## 8.2.Installation

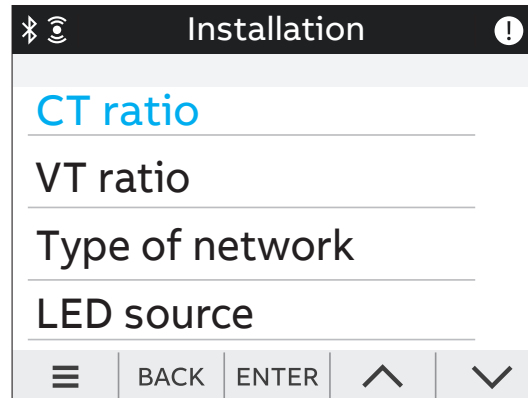
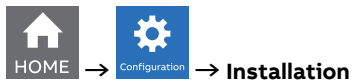

Menu	Description
CT ratio	Set the ratio of current transformers for current measurement on Line 1, 2 and 3.
VT ratio	Set the ratio of voltage transformers for voltage measurement, if any.
Type of network	Set the type of network and number of wires on which the device is installed.
LED Source	Set the source for the frontal LED.

**M4M 20-M (MID):** For MID directive, it is only possible to configure these parameters before the Lock is completed. After the lock operation, these configurations cannot be modified in order to avoid antitampering. For locked meter this settings are read only parameters.

### CT ratio menu

During the first commissioning, it is highly recommended to configure the CT ratio (please refer to chapter “7.5.CT ratio”).

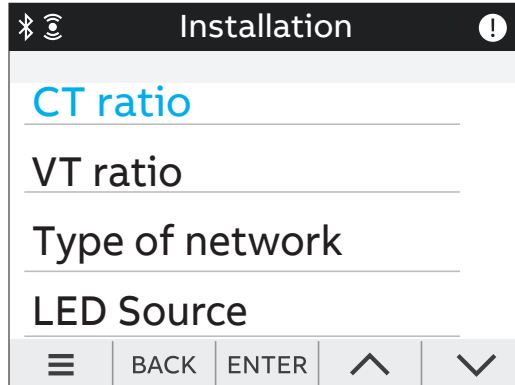

### VT ratio menu

During the first commissioning it is mandatory to configure the VT ratio (please refer to chapter “7.6.VT ratio”).

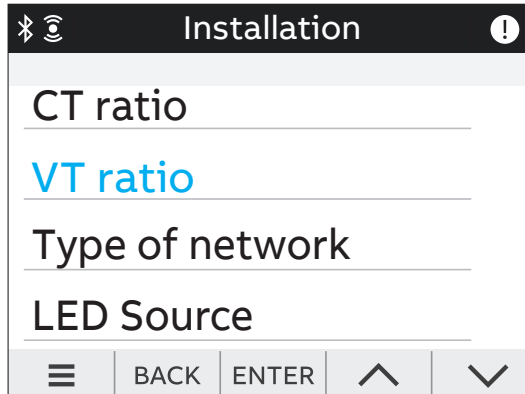

### Type of network menu

During the first commissioning, it is highly recommended to configure the Type of network (please refer to chapter “7.4.Type of network”).

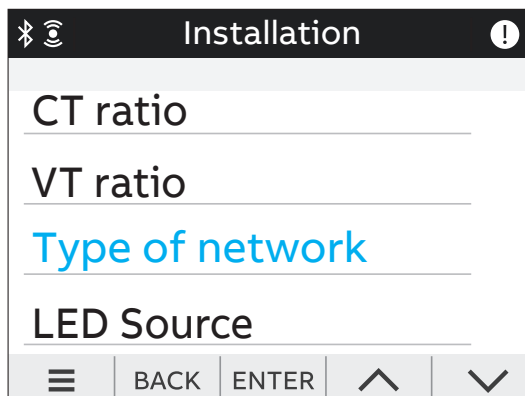

## LED Source menu

It is possible to choose the source of LED among the following options: Active, Reactive ad Apparent energy.

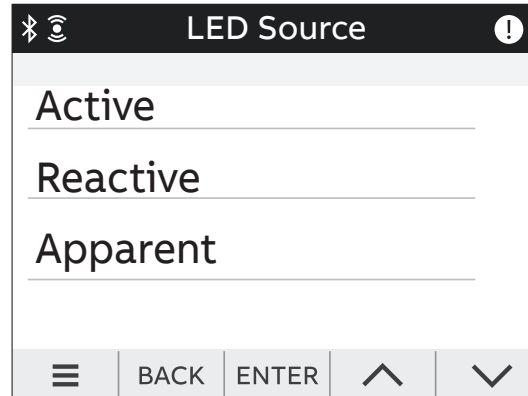

Option	Description
Active	Flashes in proportion to the active energy measured.
Reactive	Flashes in proportion to the reactive energy measured.
Apparent	Flashes in proportion to the apparent energy measured.

## 8.3.Inputs / Outputs

In this section it is possible to configure I/O slots of the meter.

The number and type of I/O on the M4M network analyzer varies according to the different product versions. Please refer to the table in “3.3 Versions” for the detail of I/O types per each M4M

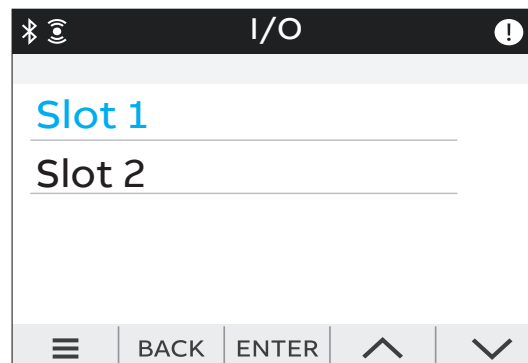
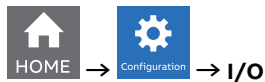

**Each programmable I/O slot can be configured as follow:**

Digital Output function:
Alarm output.
Communication output.
Pulse output.
Output ON.
Output OFF.

**M4M 20-M (MID):** For MID directive, output 1 is assigned as pulse output for active energy.

## Digital Output

Each programmable I/O can be configured as **Alarm output**, **Communication output**, **Pulse output**, **Output ON** or **Output OFF**.

Selecting **Alarm output**, the output can be associated to an alarm. Please note that it is mandatory to set up an alarm prior to setting an output as Alarm output. In case no alarms have been set up, an information pop-up will appear to inform that no alarm is set, with an hyperlink to the Alarm settings. For alarm settings, please refer to chapter "8.4.Alarms".

Selecting **Comm. output**, the output status is controlled directly via bus.

Selecting **Pulse output**, the output is set as a pulse generator associated with a measured parameter. It is needed to consecutively set a measured parameter associated to the pulse output, the pulse ratio and the pulse length.

Setting page	Description
Parameter	Total Active Import Energy, Total Active Export Energy, Net Active Energy, Total Reactive Import Energy, Total Reactive Export Energy, Net Reactive Energy, Total Apparent Import Energy, Total Apparent Export Energy, Net Apparent Energy.
Pulse ratio	Default values: 10/100/1000/5000 pulses for each kWh/kvarh/kVAh or 10/50/100 pulses for each Wh/varh/VAh. Manual between 1 and 999999 pulses for each kWh/kvarh/kVAh or pulses for each MWh/Mvarh/MVAh.
Length	Manual value between 10 and 990ms.

### • M4M 20-M (MID) digital Output

The MID active energy import total function is assigned to pulse output 1.

The pulse duration is 30 ms and is not configurable.

The frequency is not configurable. It is adjusted by the algorithm according to the voltage and current primaries, see follow:

$CT*VT \geq 1\ 000\ 000$	1 impulse/MWh
$100\ 000 \leq CT*VT < 1\ 000\ 000$	10 impulses/MWh
$10\ 000 \leq CT*VT < 100\ 000$	100 impulses/MWh
$1000 \leq CT*VT < 10\ 000$	1 impulses/MWh
$100 \leq CT*VT < 1000$	10 impulses/kWh
$10 \leq CT*VT < 100$	100 impulses/kWh
$1 < CT*VT < 10$	1000 impulses/kWh
$CT*VT = 1$	10 000 impulses/kWh

Selecting **Output ON / Output OFF**, the output acts as a **contact close / contact open**.

Selecting **Output ON** the circuit is closed, selecting **Output OFF** the circuit is open.

For output connections, please refer to chapter "5.4.Wiring diagrams".

## Input

Slots 3 and 4 of the I/O menu for M4M 20 I/O contain programmable I/O that can be configured as follows:

I/O type	I/O type
Pulse input	Pulse output
Alarm output	Output ON
Comm. output	Output OFF

Selecting **Pulse Input**, the device counts detected pulses connected to input port, that should last at least 30ms. It is needed to consecutively set a pulse ratio associated to the pulse counter, and then a unit of measurement to be associated to the pulses.

Setting page	Description
1. Pulse ratio	Manual value between 1 and 999999.
2. Unit	No unit, Wh, kWh, MWh, Varh, kVarh, MVarh, VAh, kVAh, MVAh, gal, BTU, L, m <sup>3</sup> , MCF, lbs, kg, klbs, Therm.

## Analog output

Slots 5 and 6 of the I/O menu for M4M 20 I/O contain analog outputs that can be used to associate a measured parameter to a current output value.

It is possible to define the parameter to be associated to the analog output, as well as minimum and maximum measured values to be linked to the output span.

Menu	Description
Output span	0 - 20mA or 4 - 20mA.
Parameter	Voltage L1, L2 and L3, Voltage L1-L2, L2-L3, L1-L3, Total Current, Current L1, L2, L3, Current Neutral, Current Ground, Total Active Power, L1 Active Power, L2 Active Power, L3 Active Power, Total Reactive Power, L1 Reactive Power, L2 Reactive Power, L3 Reactive Power, Total Apparent Power, L1 Apparent Power, L2 Apparent Power, L3 Apparent Power, THD Voltage L1, L2, L3, L1-L2, L2-L3, L1-L3, THD Current L1, L2, L3, N, Unbalance L-L, L-N, Unbalance Current, Frequency, Total PF, PF L1, L2, L3.
Min. value	Manual value of the measured parameter, to be associated to 0mA or 4mA (minimum).
Max. value	Manual value of the measured parameter, to be associated to 20mA (maximum).

## 8.4.Alarms

In this section it is possible to configure the single alarms, allowing to monitor certain value selected from a list of parameters.



When specific conditions are met, alarms is turned on or off. Triggering of alarms can be registered in the devices notifications log, in the alarms section. In addition to that, they can be set up to control digital outputs of the device. In order to set an output as alarm output, please refer to chapter “7.4. Inputs / Outputs”.

Up to 25 simple alarms can be configured in the device. The following graph explains how the alarm features work in relationship to threshold, delay, hysteresis.

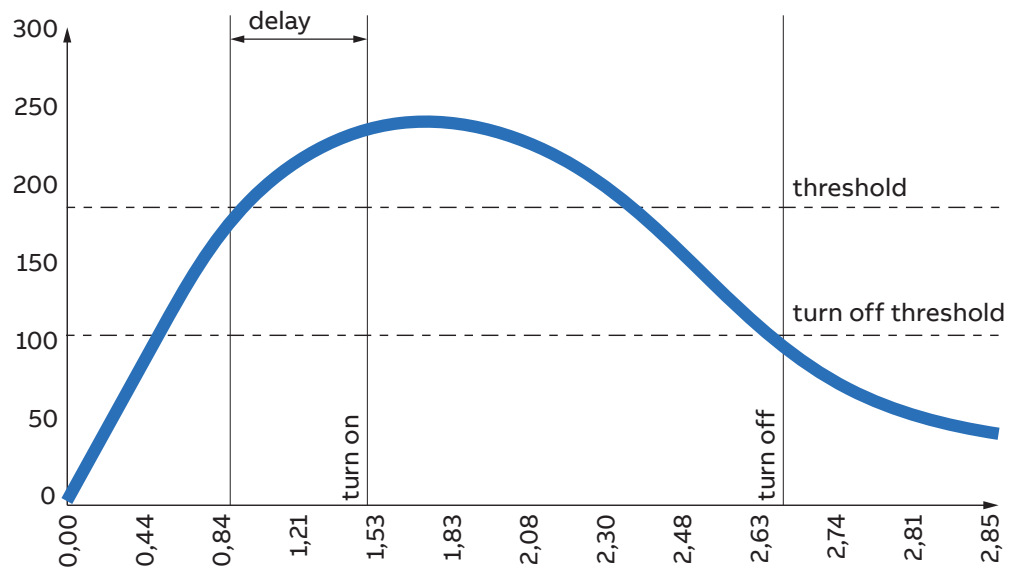

**How the alarm is turned on:** Whenever measured value crosses threshold for a time that is higher than the defined delay, timer is set and starts counting down delay. If count down is finished and the value have not crossed back the threshold, alarm is turned on. At this point, according to configuration, alarms trip is registered in the notifications log (alarm section) and/or alarm output is set High.

**How the alarm is turned off:** The alarm state is held until the value crosses turn off threshold, which is the difference between the threshold and the threshold hysteresis. Crossing turn off threshold results in turning off the alarm, thus digital output is turned off or/and it is registered in the notifications log (alarm section).

In order to set an alarm, it is needed to define the parameter associated to the alarm, the alarm type (cross up over threshold, or cross down under threshold), the threshold value for the parameter, the activation delay and the hysteresis for the turn off threshold.

Setting	Description
Parameter	Voltage (L1, L2, L3, L1-L2, L2-L3, L1-L3), Current (total, L1, L2, L3, neutral), Active Power (total, L1, L2, L3), Reactive Power (total, L1, L2, L3), Apparent Power (total, L1, L2, L3), THD Voltage (L1, L2, L3, L1-L2, L2-L3, L1-L3), THD Current (L1, L2, L3, neutral), Frequency, Power Factor (total, L1, L2, L3), Count down Timer.
Alarm Type	Cross up or Cross down.
Threshold	Manual entry from 0 to 999k.
Delay	Manual entry from 0s to 900s.
Hysteresis	Manual entry from from 0% to 40%.
Logs	Enable or Disable the logging of alarms inside notifications.

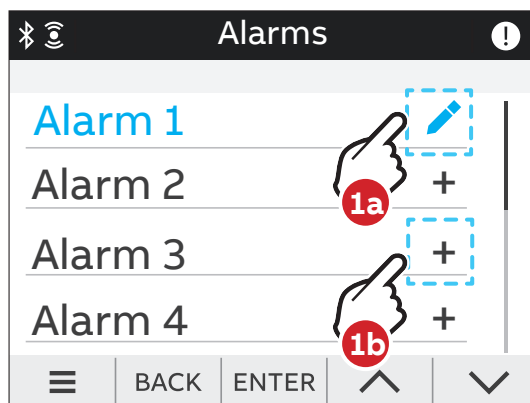

- 1a.** In case an alarm has been set, it will present an edit symbol (✎) in the list of alarms. A tap on an alarm with edit symbol allows to edit an existing alarm.
- 1b.** In case an alarm is not completely set, it will present a “+” in the list of alarms. A tap on an alarm with “+” allows to create a new alarm.

### 8.5.Communication



Communication menu allow to set all the parameters related to the communication protocol available for a specific product version. The embedded communication protocol varies according to the different product versions. Please refer to “3.3. Versions” for the details on the embedded communication protocols.

Based on product version following configuration menus are available:

#### Bluetooth (all M4M 20 product versions)

Bluetooth communication protocol is available on all product version and allow to read data via EPiC Mobile from M4M and carry out basic configuration.

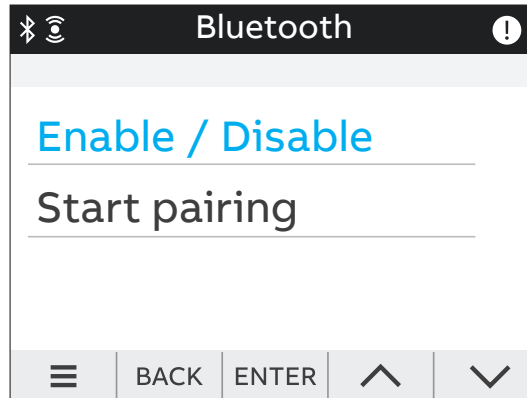

Menu	Description
Enable/Disable	Enable / disable bluetooth communication. Disabled by default.
Start paring	Starts the paring, only if Bluetooth communication is enabled.

When the Bluetooth communication is enabled, the communication active symbol  appears.

When Start pairing is selected, in order to complete the pairing with EPiC Mobile, due to Cybersecurity reasons it is needed to enter a passkey on your smartphone. The following screen will appear, followed by a passkey randomly generated by M4M.

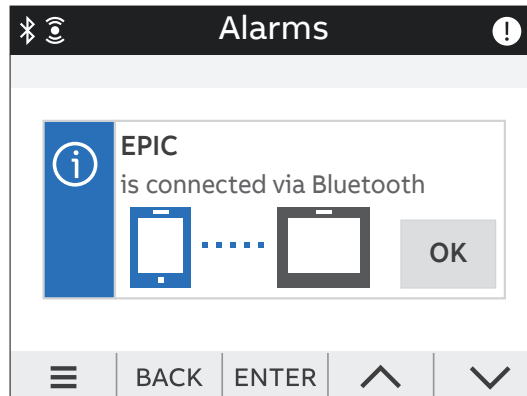

Please follow the instructions on EPiC Mobile to complete the pairing. Once the pairing is completed, a confirmation pop-up will appear on the device as per below picture:

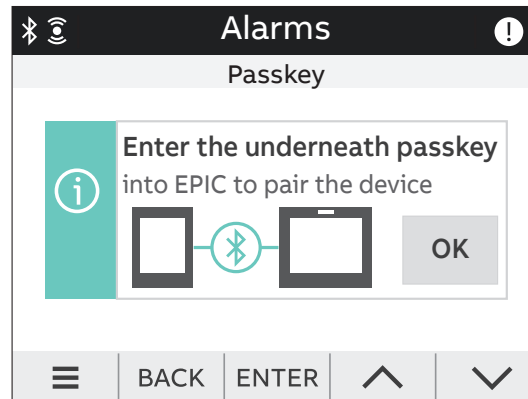

### MODBUS RTU (M4M 20 Modbus, M4M 20 I/O, M4M 20 Rogowski, M4M 20-M Modbus product versions)

This section is available on all the M4M 20 product versions with Modbus RTU embedded communication.



Menu	Description
Address	From 1 to 247.
Baud rate	9600, 19200, 38400, 57600, 115200.
Parity	Even, Odd, None.

See Modbus communication manual for details on Modbus communication protocol and communication map.

### MODBUS TCP/IP (M4M 20 Ethernet, M4M 20-M Ethernet product versions)

This section is available on all the M4M 20 product versions with Modbus RTU embedded communication.



Menu	Description
DHCP	Enable / Disable (disabled by default).
IP address	192.168.1.12 (by default).
Subnet mask	255.255.255.0 (by default).
Gateway	192.168.1.1 (by default).
TCP port	502 (by default).

If DHCP is disabled, the values of above configurations (IP address, subnet mask, gateway, TCP port) are the default ones. In this case, it is possible to modify each of above configurations.

If DHCP is enabled, it is not needed to enter the above configurations as they are automatically set.

See Modbus communication manual for details on Modbus communication protocol and communication map.

## PROFIBUS (M4M 20 Profibus product version)

This section is available on M4M 20 Profibus with Profibus DP-V0 embedded communication.



Menu	Description
Address	From 1 to 126.

If DHCP is disabled, the values of above configurations (IP address, subnet mask, gateway, TCP port) are the default ones. In this case, it is possible to modify each of above configurations.

If DHCP is enabled, it is not needed to enter the above configurations as they are automatically set.

See Profibus communication manual for details on Profibus communication protocol and communication map.

## BACNET (M4M 20 Bacnet product version)

This section is available on M4M 20 Bacnet with BACnet/IP embedded communication.



Parameter	Range	Default value	Comments
DHCP	enabled/disabled	disabled	
IP address	0.0.0.0-255.255.255.255	192.168.1.12	This address must create valid Network prefix and Host address with combination of subnet mask, accordingly to IPv4 subnetting. Additionally some ranges according to IANA organization are excluded from valid values: (127.0.0.0-127.0.0.255), (224.0.0.0-239.255.255.255) and 255.255.255.255.
Subnet mask	128.0.0.0-255.255.255.254	255.255.255.0	It must be valid according to IPv4 subnetting.
Gateway	0.0.0.0-255.255.255.255	192.168.1.1	This address follows the same restrictions as IP address of device.
UDP port	0-65535	47808	
Device instance	0-4194302	228	This ID must be unique across BACnet network.
BBMD	enabled/disabled	disabled	
BBMD IP address	0.0.0.0-255.255.255.255	0.0.0.0	
BBMD UDP port	0-65535	47808	
BBMD TTL	0-65535	0	
Ekip Connect mode	enabled/disabled	disabled	

Ekip Connect mode item shall be used only for FW upgrade via Ekip Connect desktop. When Ekip Connect mode is enabled, the device reboots and waits for FW upgrade. At the end of the firmware upgrade operation the device will reboot with the updated firmware. Once the device has rebooted, ensure that Ekip connect mode parameter is disabled.

If DHCP is disabled, the values of above configurations are the default ones. In this case, it is possible to modify each of above configurations.

If DHCP is enabled, it is not needed to enter the above configurations as they are automatically set.



See Bacnet communication manual for details on Bacnet communication protocol and communication map.

## 8.6. Other settings

In this menu it is possible to configure the time interval for average values calculation, timers settings, energy conversion parameters.

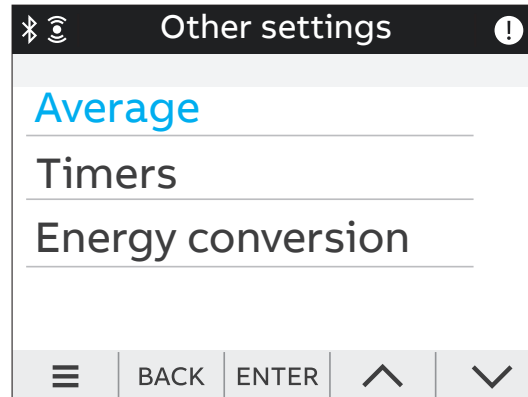
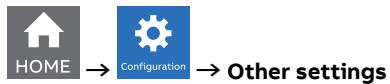

Menu	Description
Average	Configuration of time interval for Average values.
Timers	Configuration of count-down timer and timer reset.
Energy conversion	Configuration of conversion factors for energy.

### Average menu

In this menu it is possible to configure the time interval used for calculation of average parameters that can be read out in Data reading -> Average. For the data reading of average values please refer to chapter "9.4.Average".

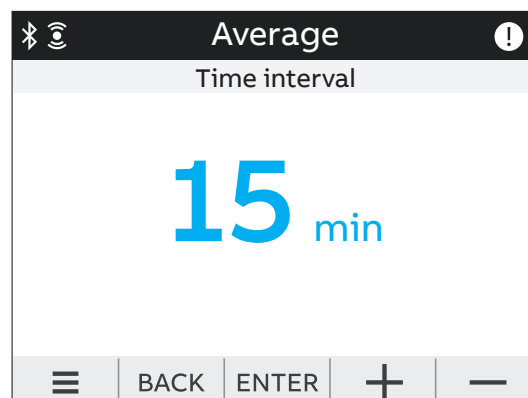
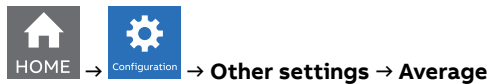

Setting	Description
Time interval	Manual entry from 1 to 60m. Default: 15m

**Timers menu**

In this menu it is possible to configure the count-down timer, used for maintenance notification, and the timers reset.

For the data reading of timers values please refer to chapter “9.10.Timers”.

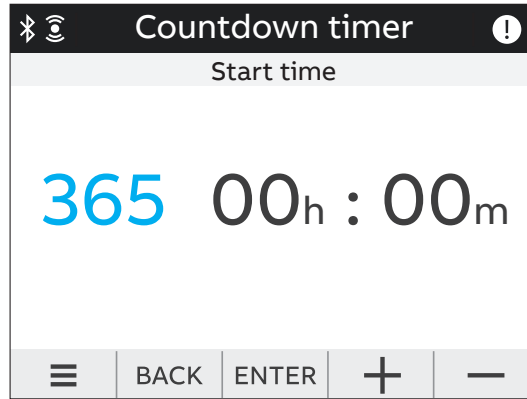
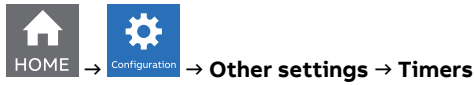

Menu	Description
Count-down timer	Used for the count of the system operating time.
Timers reset	Reset of the count-down timer

If countdown timer menu is chosen, the screen above will appear, allowing to manually enter the value in the format days: hours: minutes.

**Energy conversion menu**

In this menu it is possible to configure the conversion factors in order to associate the consumption of active energy to the local currency or to CO<sub>2</sub>.

For the data reading of converted values please refer to chapter “9.2.Energy”.

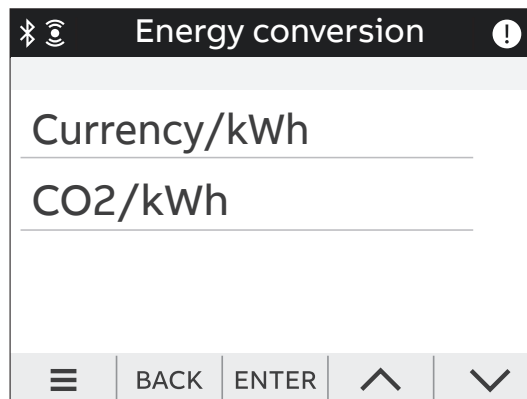

Menu	Description
Currency/kWh	Currency conversion factor that allows to display the equivalent of active 3-phase energy in local currency. Factor has to be defined as currency/kWh.
CO <sub>2</sub> /kWh	CO <sub>2</sub> conversion factor that allows to display the equivalent of active 3-phase energy in CO <sub>2</sub> . Factor has to be defined as kg CO <sub>2</sub> /kWh.

## 9.Data Reading

Data reading section allows to visualize all the parameters measured by M4M.

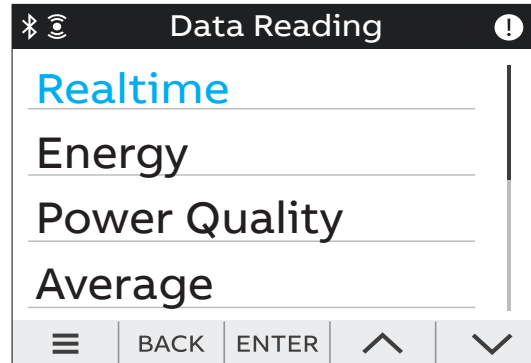

Press **BACK** to return to the home page.

### 9.1.Realtime



<b>Realtime measurement</b> Summary U 3P <b>399.11 V</b> I 3P <b>2.936 kA</b> P 3P <b>1.999 kW</b>	<b>Realtime measurement</b> Line-Neutral voltage 399.11 V L1 <b>230.05 v</b> L2 <b>231.14 v</b> L3 <b>228.68 v</b>	<b>Realtime measurement</b> Line-Line voltage 399.11 V L12 <b>399.87 v</b> L23 <b>398.73 v</b> L13 <b>397.45 v</b>	<b>Realtime measurement</b> Current 2.936 kA L1 <b>3.455 kA</b> L2 <b>1.324 kA</b> L3 <b>4.102 kA</b>
<b>Realtime measurement</b> Current 2.936 kA N <b>0.702 kA</b>	<b>Realtime measurement</b> Active power 1.999 kW L1 <b>0.774 kW</b> L2 <b>0.300 kW</b> L3 <b>0.925 kW</b>	<b>Realtime measurement</b> Reactive power 0.325 kvar L1 <b>0.109 kvar</b> L2 <b>0.085 kvar</b> L3 <b>0.131 kvar</b>	<b>Realtime measurement</b> Apparent Power 2.030 kVA L1 <b>0.782 kVA</b> L2 <b>0.313 kVA</b> L3 <b>0.935 kVA</b>
<b>Realtime measurement</b> Frequency 50.03 Hz			

Visualization page	Description
Summary	3-phase voltage (line to line), 3-phase current, total active power.
Line-Neutral voltage	Line to neutral voltage per phase and 3-phase line to line voltage.
Line-Line voltage	Line to line voltage per phase and 3-phase line to line voltage.
Current (L1,L2,L3)	Current per phase and 3-phase current.
Current (N)	Neutral phase and 3-phase current.
Active Power	Active power per phase and total.
Reactive power	Reactive power per phase and total.
Apparent power	Apparent power per phase and total.
Frequency	System frequency.

Press ^ | v keys to change the parameters visualization.

## 9.2. Energy



<b>Energy</b> Active Energy - Import <b>1512.7</b> Wh	<b>Energy</b> Reactive Energy - Import <b>510.56</b> varh	<b>Energy</b> Apparent Energy - Import <b>1596.54</b> VAh	<b>Energy</b> Active Energy - Export <b>356.23</b> Wh
<b>Energy</b> Reactive Energy - Export <b>120.23</b> varh	<b>Energy</b> Apparent Energy - Export <b>375.97</b> VAh	<b>Energy</b> Active Energy - Net <b>1156.47</b> Wh	<b>Energy</b> Reactive Energy - Net <b>390.33</b> varh
<b>Energy</b> Apparent Energy - Net <b>1220.56</b> VAh	<b>Energy</b> Equivalent CO2/kWh I <b>0.756</b> g E <b>0.178</b> g N <b>0.578</b> g	<b>Energy</b> Equivalent Currency/kWh I <b>0.09</b> CU E <b>0.02</b> CU N <b>0.07</b> CU	

### Visualization page

Active Energy - Import	Total imported active energy in Wh/kWh/MWh.
Reactive energy - Import	Total imported reactive energy in varh/kvarh/Mvarh.
Apparent energy - Import	Total imported apparent energy in VAh/kVAh/MVAh.
Active Energy - Export	Total exported active energy in Wh/kWh/MWh.
Reactive Energy - Export	Total exported reactive energy in varh/kvarh/Mvarh.
Apparent Energy - Export	Total exported apparent energy in VAh/kVAh/MVAh.
Active Energy - Net	Net value of active energy import/export total in Wh/kWh/MWh.
Reactive Energy - Net	Net value of reactive energy import/export total in varh/kvarh/Mvarh.
Apparent Energy - Net	Net value of apparent energy import/export total in VAh/kVAh/MVAh.
Equivalent CO2/kWh	CO2 emission linked to imported (I), exported (E) and net energy. To set the conversion factor go to Configuration - Other settings - Energy conversion.
Equivalent Currency/kWh	Currency linked to imported (I), exported (E) and net energy. To set the conversion factor go to Configuration - Other settings - Energy conversion.

### 9.3.Power Quality



<p><b>Power Quality</b></p> <p>THD Line-Neutral Voltage</p> <p>L1 <b>42.1</b> %</p> <p>L2 <b>42.2</b> %</p> <p>L3 <b>42.2</b> %</p>	<p><b>Power Quality</b></p> <p>THD Line-Line Voltage</p> <p>L12 <b>27.4</b> %</p> <p>L23 <b>27.3</b> %</p> <p>L13 <b>27.2</b> %</p>	<p><b>Power Quality</b></p> <p>THD Current</p> <p>N 289.0 %</p> <p>L1 <b>11.0</b> %</p> <p>L2 <b>11.1</b> %</p> <p>L3 <b>11.1</b> %</p>	<p><b>Power Quality</b></p> <p>Unbalances</p> <p>VLN <b>0.1</b> %</p> <p>VLL <b>0.1</b> %</p> <p>I <b>0.2</b> %</p>
<p><b>Power Quality</b></p> <p>Power Factor</p> <p>0.981</p> <p>L1 <b>0.990</b></p> <p>L2 <b>0.909</b></p> <p>L3 <b>0.969</b></p>	<p><b>Power Quality</b></p> <p>Cosphi</p> <p>0.976</p> <p>L1 <b>1.000</b></p> <p>L2 <b>0.940</b></p> <p>L3 <b>0.986</b></p>		

Visualization page	Description
THD Line-Neutral voltage	Per phase line to neutral voltage THD values.
THD Line-Line voltage	Per phase line to line voltage THD values.
THD Current	Total and per phase current THD values.
Unbalances	Unbalances values for line to neutral voltage (VLN), line to line voltage (VLL) and current (I).
Power Factor	Total and per phase power factor.
Cosphi	Total and per phase cosphi (displacement factor).

## 9.4.Average



<b>Average</b> Line-Neutral Voltage L1 <b>228.15 V</b> L2 <b>229.32 V</b> L3 <b>227.26 V</b>	<b>Average</b> Line-Line Voltage L12 <b>395.16 V</b> L23 <b>397.19 V</b> L13 <b>393.62 V</b>	<b>Average</b> Current L1 <b>954.22 A</b> L2 <b>841.64 A</b> L3 <b>985.39 A</b>	<b>Average</b> Current N <b>115.41 A</b>
<b>Average</b> Active Power <b>2.419 kW</b> L1 <b>841.22 W</b> L2 <b>691.10 W</b> L3 <b>887.64 W</b>	<b>Average</b> Reactive Power <b>721.2 var</b> L1 <b>247.1 var</b> L2 <b>219.3 var</b> L3 <b>254.8 var</b>	<b>Average</b> Apparent Power <b>2.794 kVA</b> L1 <b>954.1 VA</b> L2 <b>846.2 VA</b> L3 <b>994.1 VA</b>	

Visualization page	Descriptions
Average Line-Neutral Voltage	Average per phase line to neutral voltage calculated for a defined period of time (default: 15 minutes).
Average Line-Line Voltage	Average per phase line to line voltage calculated for a defined period of time (default: 15 minutes).
Average Current (L1,L2,L3)	Average per phase calculated for a defined period of time (default: 15 minutes).
Average Current (N)	Average neutral and ground calculated for a defined period of time (default: 15 minutes).
Average Active Power	Average calculated for a defined period of time (default: 15 minutes).
Average Reactive Power	Average calculated for a defined period of time (default: 15 minutes).
Average Apparent Power	Average calculated for a defined period of time (default: 15 minutes).

### 9.5.Min Value

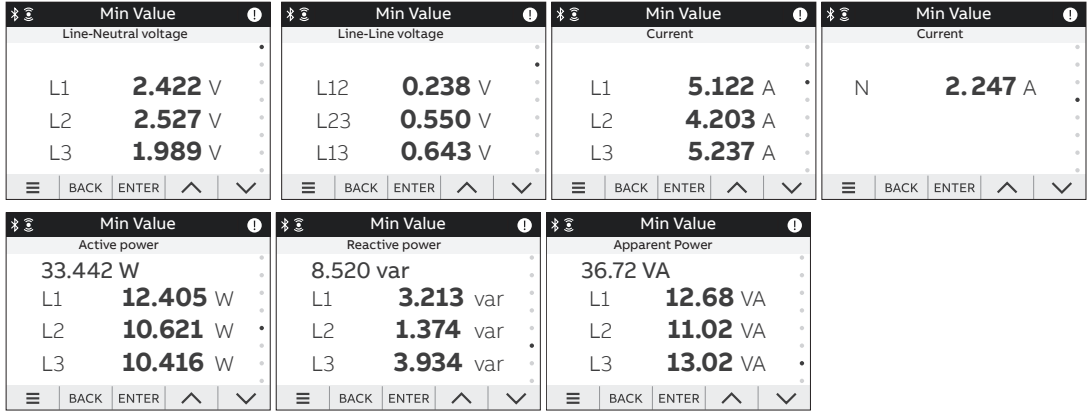

Visualization page	Descriptions
Minimum Line-Neutral Voltage	Minimum per phase line to neutral voltage measured value.
Minimum Line-Line Voltage	Minimum per phase line to line voltage measured value.
Minimum Current (L1, L2, L3)	Minimum per phase measured current.
Minimum Current (N)	Minimum neutral and current.
Minimum Average Active Power	Minimum average value measured in a defined period of time (default: 15 minutes).
Minimum Average Reactive Power	Minimum average value measured in a defined period of time (default: 15 minutes).
Minimum Average Apparent Power	Minimum average value measured in a defined period of time (default: 15 minutes).

## 9.6.Max Value



<p><b>Max Value</b></p> <p>Line-Neutral voltage</p> <p>L1 <b>230.05</b> v</p> <p>L2 <b>231.14</b> v</p> <p>L3 <b>228.68</b> v</p>	<p><b>Max Value</b></p> <p>Line-Line voltage</p> <p>L12 <b>399.87</b> v</p> <p>L23 <b>398.73</b> v</p> <p>L13 <b>397.45</b> v</p>	<p><b>Max Value</b></p> <p>Current</p> <p>L1 <b>3.120</b> A</p> <p>L2 <b>1.951</b> A</p> <p>L3 <b>4.502</b> A</p>	<p><b>Max Value</b></p> <p>Current</p> <p>N <b>0.941</b> kA</p>
<p><b>Max Value</b></p> <p>Active power</p> <p><b>624.55</b> kW</p> <p>L1 <b>210.01</b> kW</p> <p>L2 <b>205.65</b> kW</p> <p>L3 <b>208.93</b> kW</p>	<p><b>Max Value</b></p> <p>Reactive power</p> <p><b>104.5</b> kvar</p> <p>L1 <b>35.24</b> kvar</p> <p>L2 <b>36.78</b> kvar</p> <p>L3 <b>32.43</b> kvar</p>	<p><b>Max Value</b></p> <p>Apparent Power</p> <p><b>662.6</b> kVA</p> <p>L1 <b>220.9</b> kVA</p> <p>L2 <b>220.9</b> kVA</p> <p>L3 <b>220.8</b> kVA</p>	

Visualization page	Descriptions
Maximum Line-Neutral Voltage	Maximum per phase line to neutral voltage measured value.
Maximum Line-Line Voltage	Maximum per phase line to line voltage measured value.
Maximum Current (L1, L2, L3)	Maximum per phase measured current.
Maximum Current (N)	Maximum neutral and ground measured current.
Maximum Average Active Power	Maximum average value measured in a defined period of time (default: 15 minutes).
Maximum Average Reactive Power	Maximum average value measured in a defined period of time (default: 15 minutes).
Maximum Average Apparent Power	Maximum average value measured in a defined period of time (default: 15 minutes).

### 9.7.I/O

The number and type of I/O on the M4M network analyzer varies according to the different product versions. Please refer to the table in “3.4.Versions” for the detail of I/O types per each M4M.

For each I/O specific information is shown according to the I/O type. Below an example for digital output set as pulse output

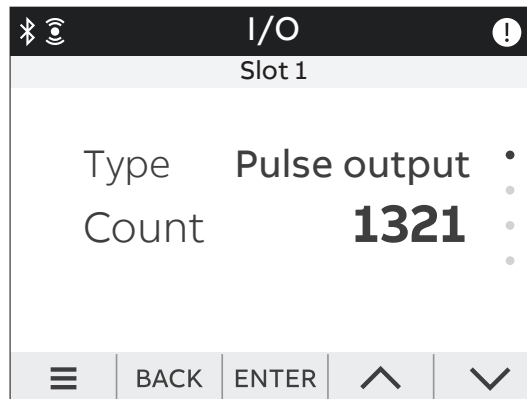

Info visualized	Description
Type	How I/O slot has been configured.
Count	Number of pulses counted by the I/O. It is only available if the I/O slot has been configured as Pulse input or Pulse output.
State	Status of the I/O. It is only available if the I/O slot has been configured as Pulse Output, Output ON, Output OFF or Comm. output.

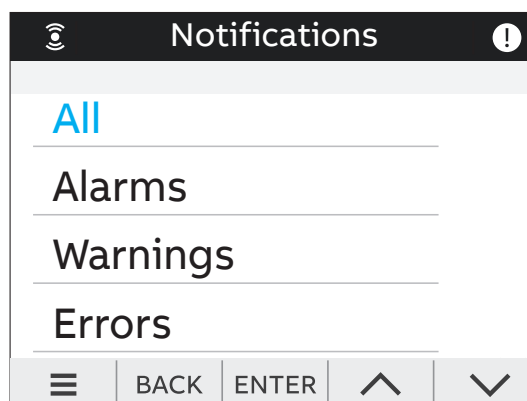

### 9.8.Notifications

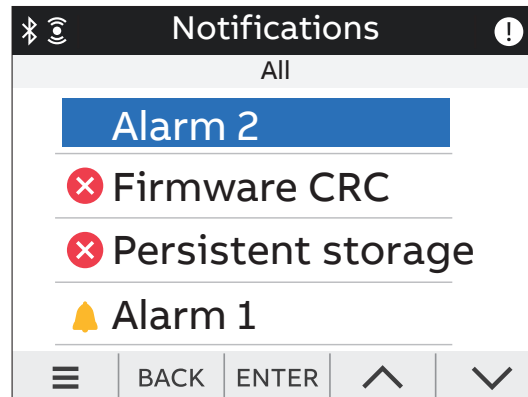

Menu item	Description
All	All alarms, warnings, errors displayed in chronological order (latest first).
Alarms	User settable, related to specific parameters, threshold, etc.
Warnings	Related to installation conditions and device settings.
Errors	Related to the device and to its self-diagnostics.

## All



Symbol	Description
	Alarms
	Warnings
	Errors

When one of the notifications is selected, the timestamp of the notification will be shown, indicating date and time of the alarm, warning or error.

## Alarms

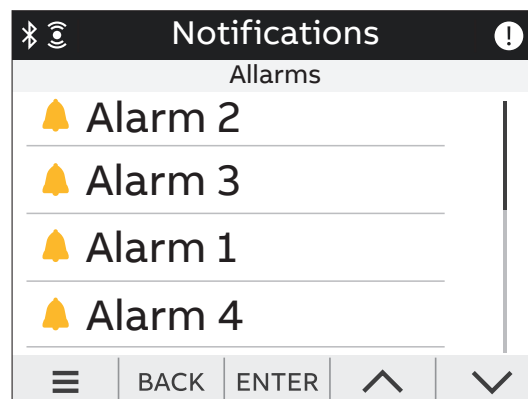

If one of the alarms is selected, timestamp (Day, Hour) will be shown. Day format is YYYY:MM:DD, time format is hh:mm:ss.

## Warnings

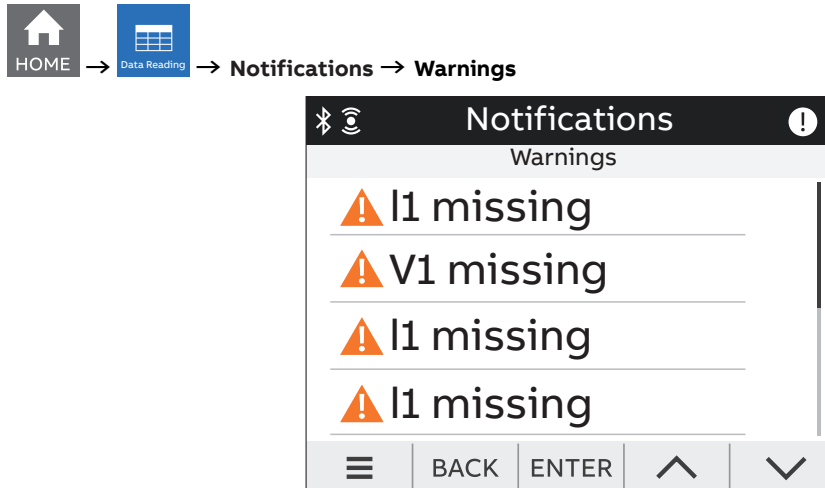

If one of the warnings is selected, timestamp (Day, Hour) will be shown. Day format is YYYY:MM:DD, time format is hh:mm:ss.

Below the list of possible warnings:

- Not Locked device (only MID version)
- Negative power L1/L2/L3/Total
- Frequency out of the metering limit
- Date not set
- Time not set
- V2/V3 connected (and it is single-phase system)
- V1 missing
- V2/V3 missing (and it is not single-phase system)
- I1 missing
- I2/I3 missing (and it is not single-phase system)
- I2/I3 connected (and it is single-phase system)
- L1/L2/L3 connected to N
- I/O Pulse 1/2/3/4/5/6 merged pulse
- Power Fail

## Errors

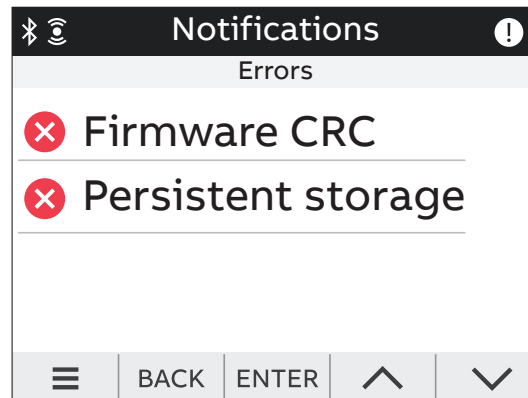

Below the list of possible errors:

- Audit log error
- Firmware CRC error
- Persistent storage error
- RAM memory CRC error
- Firmware upgrade invalid image error
- Firmware upgrade maximum count error
- Firmware upgrade error
- Firmware upgrade maximum invalid image count error
- Analog circuit reference error
- Analog circuit temperature error
- RTC circuit error

## 9.9. Power outages



At each power fail condition, has stored in the persistent storage a power outage log.

It is possible to have up to 50 entries in cycle way. It is not possible to erase the power outages log entries.

### M4M 20-M (MID) Power outages

Power outages notifications icons can be disabled via the following key combination:

1. Go to Warnings menu
2. Short click of hamburger button
3. Long click of up arrow
4. Long click of hamburger button

## 9.10. Timers

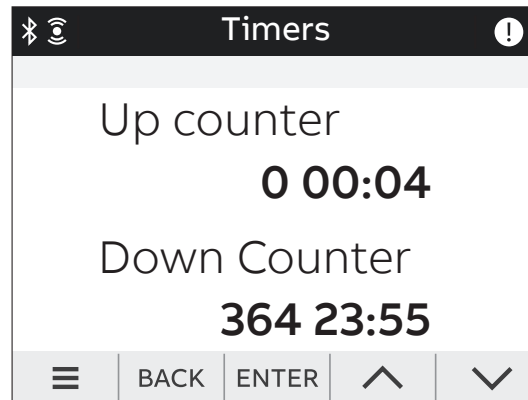

Menu	Description
Up counter	Represents the timer count up of the device lifetime since the power up.
Down counter	Represents the timer count down for the device maintenance.

## 10. Graphs

In the Graphs section it is possible to visualize the main realtime parameters measured by M4M as bargraphs.

Bargraphs show in an intuitive way the realtime values of voltage, current and power.

The graphs are automatically scaled according to the values that are measured in realtime.

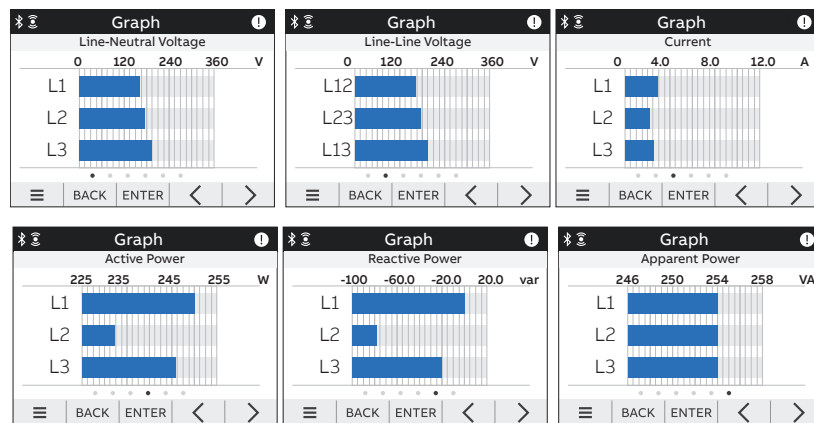

---

### Graph

---

Line-Neutral Voltage

---

Line-Line Voltage

---

Current

---

Active Power

---

Reactive Power

---

Apparent Power

---

---

## 11.Maintenance

This product contains no parts that can be repaired or exchanged. A broken meter must be replaced.

If you need assistance please contact ABB.

Do not open the meter case and do not attempt to repair any component. Opening the meter will void accuracy and calibration.

A series of horizontal dotted lines spanning the width of the page, intended for writing or drawing.



---

**ABB S.p.A**

Electrification business  
Viale dell'Industria, 18  
20009 Vittuone (MI) Italy  
[new.abb.com/low-voltage](http://new.abb.com/low-voltage)

