

# HEADLIGHT BEAM TESTER 505.003.170

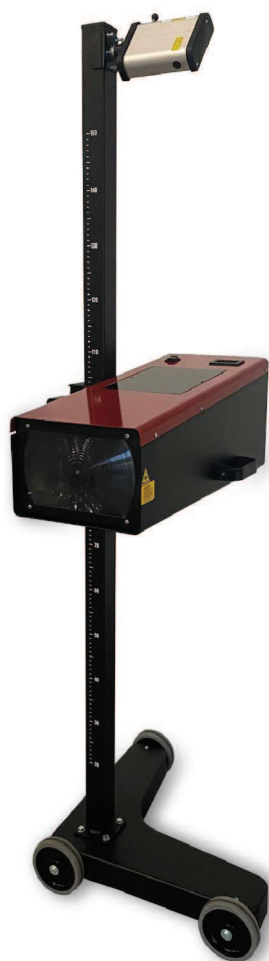

EN

## HEADLIGHT BEAM TESTER 505.003.170

### MAINTENANCE AND OPERATING MANUAL

Original version in Italian language

*This manual of use is an integral part of the machine and must be properly guarded to maintain its integrity and allow its consultation during the life of the equipment.*

*Consult this manual carefully before making any intervention on the equipment*

The manufacturer has the power to make changes to the production and manual, without this entails the obligation to update the production and previous manuals.

ENGLISH

Kraftwerk Group AG Mettlenbachstrasse 23 CH-8617 Mönchaltorf Switzerland  
Tel. +41-44 949 40 50 [www.kraftwerktools.com](http://www.kraftwerktools.com)

ENGLISH

Index:

|   |    |
|---|----|
| 1. PREMISES.....                                    | 18 |
| 2. OVERALL INFORMATION .....                        | 18 |
| 2.1 Definition and symbols.....                     | 18 |
| 2.1.1 Definition .....                              | 18 |
| 2.1.2 Symbols.....                                  | 19 |
| 3. MANUFACTURER IDENTIFICATION.....                 | 19 |
| 3.1 About technical support and maintenance.....    | 19 |
| 4. TECHNICAL DATA SHEET.....                        | 19 |
| 4.1 Basic Configuration .....                       | 19 |
| 4.2 Configurations.....                             | 20 |
| 4.2.1 Kit single laser (Art. 505.003.170 / L1)..... | 20 |
| 4.2.2 Kit double laser (Art. 505.003.170/L2).....   | 20 |
| 4.2.3 Options.....                                  | 20 |
| 4.3 Reference Regulations .....                     | 20 |
| 5. INSTALLATION AND STORAGE.....                    | 20 |
| 5.1 Equipment receipt checks .....                  | 20 |
| 5.2 Installation instructions.....                  | 21 |
| 5.3 Storage .....                                   | 22 |
| 6. GENERAL DESCRIPTION .....                        | 22 |
| 6.1 Reports, commands, status information.....      | 22 |
| 7. MEASURE GUIDELINE .....                          | 22 |
| 7.1 Getting Started.....                            | 22 |
| 7.2 Headlight tester positioning.....               | 23 |
| 7.2.1 Mirror visor alignment method .....           | 23 |
| 7.2.2 Laser visor alignment method .....            | 23 |
| 7.2.3 Headlight beam optical center alignment ..... | 24 |
| 7.3 Measurement Process .....                       | 24 |
| 7.3.1 Ec headlight beam.....                        | 24 |
| 8. UNDERSTANDING OF MEASURED VALUES.....            | 26 |
| 8.1 Ece european standards.....                     | 26 |
| 8.1.1 Low beam pattern .....                        | 26 |
| 8.1.2 High beam pattern .....                       | 26 |
| 8.1.3 Fog beam pattern.....                         | 26 |
| 8.1.4 Intelligent beam .....                        | 26 |
| 9. MISFUNCTIONING AND ANOMALIES.....                | 28 |
| 10. DISPOSAL.....                                   | 28 |
| 11. INTERVENTION REQUEST FORM - SPARE PARTS .....   | 28 |
| 12. ANNEX LIST.....                                 | 28 |
| 13. WARRANTY.....                                   | 28 |

## 1. PREMISES

Dear Partner,

thanking you for choosing our product to be part of your equipment, we invite you to follow the guidelines of the manual. Operating manual will support you in a proper use and maintenance of the product during the time.

## 2. OVERALL INFORMATION

This manual is an integral part of the equipment and it is an essential support for the implementation and proper use of the unit.

Read it carefully and completely before installing and using the equipment.



The manual must be present with the equipment in case of resale.

Partial reproduction of this document without written Kraftwerk permission is prohibited.

### 2.1 DEFINITIONS AND SYMBOLS

Below are a series of definitions, terminology and symbols used in the writing of this manual.

#### 2.1.1 Definitions

| Symbol  | Description  |
|---|--|
|  | <b>1st level operator:</b> Trained and informed operator able to use the equipment in normal operating conditions and for simple maintenance.  |
|  | <b>Operator of the manufacturer:</b> qualified manufacturer technician can carry out complex operations, situations or, in any case, what is agreed with the user. Skills are, as appropriate, mechanical and/or electrical and/or electronic and/or software. |

## 2.1.2 Symboles

### NOTE



It provides important information to be read paying attention for a proper and correct use of the equipment.

### DANGER



It indicates a situation that can result in injuries, even fatalities, or serious damage to health.

### ATTENTION



It indicates a situation that could cause, even indirectly, damage to people, things and the environment with economic consequences.

### WARNING



It indicates that you need to carefully follow the directions. Failure to comply with the report may cause malfunctions or dangerous conditions or damage.

## SAFETY PICTOGRAMS

Warning signs (caution, caution check)

|  |   |  |
|--|---|--|
|  | Direct beam vision is potentially dangerous |  |
|  | Stumbling danger                            |  |

Prohibition signs (Dangerous, Hazardous behaviour, Interruption Devices, Emergency)

|  |  |
|--|--|
|  | Prohibition of using water to extinguish fires |
|--|--|

## 3. MANUFACTURER IDENTIFICATION

The label on the side of the equipment contains all the identifying data.

The figure below shows the format of the label.



**Mod.** = Equipment model

**Art.** = Equipment identification code

**Year** = Production year

**Serial no.** = Manufacturing serial number

**Weight:** = Equipment weight



It is absolutely forbidden to remove or tamper with such a license plate. If this license plate is accidentally damaged, contact the manufacturer.

## 3.1 About technical support and maintenance

For communications or requests for information or spare parts, send the form "spareparts list, malfunctioning issue, warning issues" in **Annex 1**.

To maintain warranty coverage, Customer



must follow manual instructions. Otherwise, product problems or malfunctions in the operation of the equipment will not be covered by warranty terms (in this regard, read carefully the warranty attached to the manual).



In order to adapt the equipment to technological progress and specific production requirements, the manufacturer may decide, without any warning, to make changes on it without requiring the obligation to update production and previous manuals. In addition, if the illustrations in this manual differ slightly from the equipment in your possession, the safety and indications of operation of the same are always guaranteed.

## 4. TECHNICAL DATA SHEET

### 4.1 Basic configuration

|  |                      |          |
|--|----------------------|----------|
| Mirror visor for alignment (reflection mode) |                      |          |
| Test set up and measurement sizes            |                      |          |
| Set up orientation test                      | Range of measurement | Distance |
| VISUAL CHECK - UP and DOWN                   | 0 - 40 cm            | 10 m     |
|  | 0 - 4 %              |          |
|  | 0 - 2.288°           |          |
| VISUAL CHECK - RIGHT and LEFT                | 0 - 100 cm           |          |
|  | 0 - 10 %             |          |
|  | 0 - 6.000°           |          |
| Measure                                      |                      |          |
| Light intensity (lux)                        | 0 - 240              | 25 m     |
|  | 0 - 150.000          | 1 m      |
| Intensità luminosa (cd)                      | 0 - 150.000          | 25 m     |
| Operating height (center of the beam-floor)  | from 240 to 1400 mm  |          |
| Protection degree of the case:               | IP40                 |          |

|   |  |
|---|--|
| Condizioni ambientali di funzionamento: |  |
| – Temperatura:                          | 5 °C – 45 °C   |
| – Umidità relativa:                     | 20 - 80% non condensante   |
| – Pressione atmosferica:                | 0,7 ÷ 1,04 atm   |
| Operating environmental conditions:     |  |
| - Temperature:                          | -25 ÷ 45 °C  |
| - Relative humidity:                    | ≤95% non-condensing.   |
| - Pressure:                             |  |
| Overall dimensions                      | 630 - 1720 - 330 mm (width – length - height)  |
| Weight                                  | Kg 34  |
| Battery                                 | Version 505.003.170 _ 505.003.170/D Alkahaline Battery 9V<br>Version 505.003.170/I Battery 12V |

## 4.2 Configurations

At customer request the basic model can be integrated with a series of accessories.

The accessories that can be installed on the base model are identified in the equipment item code by a set of alphanumeric characters as follows:

### A LUXMETER

“.” = Analogic luxmeter  
D = Digital Luxmeter

### B LENS

K = Fresnel  
V = Glass 200

### C CONFIGURATION

R1 = Base with “V” rails  
Y = 2 parts column  
S = 1 photodiode (high beam)  
PP = Polish checking panel

### D ALIGNMENT SYSTEMS

- = Vehicle alignment with mirror visor  
L1 = Vehicle alignment with laser pointer and mirror visor  
L2 = Vehicle alignment with laser pointer and laser visor  
LL = Vehicle alignment with laser visor

#### 4.2.1 Kit single laser (Art. 505.003.170/L1 )

Headlight alignment is implemented via a laser pointer, the alignment of the vehicle is carried out via the mirror visor.

|                                 |                |
|---------------------------------|----------------|
| Headlight beam centering method |                |
| Laser Class                     | 2              |
| Line shape                      | 90 ° x 0.5mrad |
| Wave length                     | 650nm          |
| Power                           | <=1mW          |

#### 4.2.2 Kit double laser (Art. 505.003.170/L2)

Headlight beams alignment is implemented via laser pointer, alignment to the vehicle is done through the laser visor.

|                          |                             |
|--------------------------|-----------------------------|
| Vehicle alignment method |                             |
| Laser Class              | 3R                          |
| Line shape               | 130 ° x 0.5mrad             |
| Wave length              | 635nm                       |
| Power                    | 5mW                         |
| Power supply 3 – 5 V     | Stilo Battery AA 1,5 V (x3) |

#### 4.2.3 Options

After you purchase the center-forward, you can install:

##### 13.1.1.1 Handle /MP

Possibility to assemble a handle on the base to maneuver the product.

## 4.3 Reference Regulations

The legislative references applied are:

- 2014/30/UE EMC Directive
- ISO 10604 Equipaggiamenti per l'orientamento dei fari – veicoli su strada
- 2011/65/CE RoHS2 Directive

## 5. INSTALLATION AND STORAGE

### 5.1 Equipment receipt checks

When the equipment is received, remove the packaging and ensure the integrity of the content.



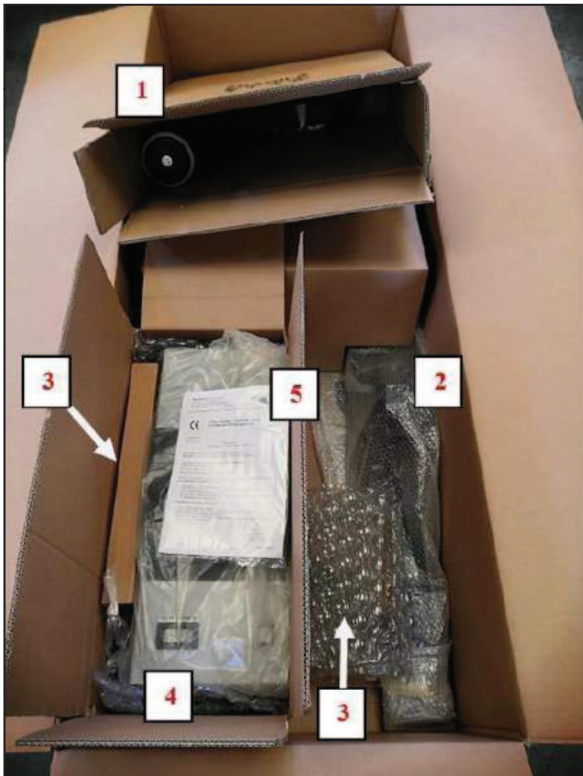

- Within the packaging there are the following parts:
1. Box containing the base
  2. Column group
  3. Mirror or laser visor
  4. Optical camera
  5. Maintenance and operating manual
  6. Certification of EC Conformity
  7. Mounting accessories



If there is damage or missing items, or if there are defects or damages, do not try to repair the equipment but contact the service center by reporting the model, code and serial number of the equipment (see Figure 2.2.1. License plate data label). Store the package, including the original packaging material, in case you need to ship the product to be repaired.



Periodically clean the equipment casing using a soft cloth moistened with neutral and non-aggressive detergents and dry with a dry cloth.

## 5.2 Installation instructions







**Level 1 operator:** trained and informed operator able to use the equipment in normal operating conditions and for simple maintenance.

Equipment:

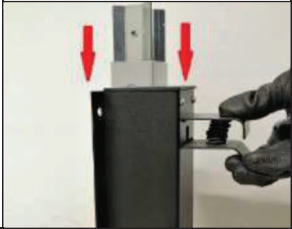
- Flat screwdriver
- x2 keys 13 mm
- Allen 6 mm

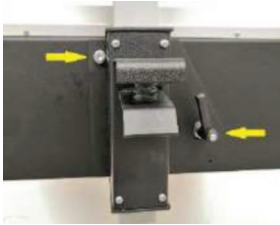
The following steps describe the operating assembling sequence.

|   |  |
|---|--|
| <p><b>1.</b> Insert the base into the column using the 4 nuts out of its seat</p>            | <p><b>2.</b> insert the sliding system</p>   |
| <p><b>3.</b> Insert the second half of the column and fix it with the 2 lateral screws</p>  | <p><b>4.</b> Position the structure vertically, checking the correct orientation between base and column.</p>   |
| <p><b>5.</b> Take the optical box and fix it with the screw and lever to the structure</p>  | <p><b>6.</b> Remove the visor from the box and screw it to the support block. Then tighten through the hole in the viewer. Assembly is the same for mirror or laser visor.</p>  |

**Battery replacement 9V:**

Open the battery box cover unscrewing the 2 positions. Disconnect the cable plug. Replace the 2 batteries, connect the cable, lock the battery box case and screw it back



**5.3 Storage**



In the case of long term storage of the equipment, pay attention that headlight tester is properly stored protected by

rain/water/high humidity rate. Check also environment are to be dry and dust free.

**5. GENERAL DESCRIPTION**



The headlight tester is a device suitable for the control of the headlights of all types of motor vehicles, vehicles and heavy vehicles in general.

The equipment is movable, so equipped with a base mounted on rubber wheels (1) in addition, it is equipped with a system of alignment to the vehicle via visor, which can be mirror or laser (2).

The optical box (3) is adjustable in height through a sliding system on precise and silent plastic skates and balanced by a spring mounted inside a sheet metal cover and column, column displays centimeter scale for the exact positioning in connection with optical box working height.

The equipment is equipped with a luxmeter, which can be analog or digital (4) where the light intensity value read by the optical box will be displayed.

**6.1 Reports, commands, status information**

| Analog Luxmeter                                   | Digital Luxmeter                                  |
|---|---|
|   |   |
| Low beam reading<br>• Kcd – Klux1mt<br>• Lux25mt  | Low beam reading<br>• Kcd – Klux1mt<br>• Lux25mt  |
| High beam reading<br>• Kcd – Klux1mt<br>• Lux25mt | High beam reading<br>• Kcd – Klux1mt<br>• Lux25mt |

|  |                                  |
|--|----------------------------------|
|  | Light intensity selection button |
|  | Low beam icon                    |
|  | High beam icon                   |

| GENERIC LEGEND FOR VALUES DI REFERENCE LIGHT INTENSITY READINGS |             |             |              |
|---|-------------|-------------|--------------|
| TYPE BEAM   |             |             |              |
| MIN Cd  | 3.750 cd    | 20.000 cd   | 1.700 cd     |
| MAX Cd  | 90.000 cd   | 150.000 cd  | 11.500 cd    |
| MIN Kcd   | 3,75 Kcd    | 20 Kcd      | 1,7 Kcd      |
| MAX Kcd   | 90 Kcd      | 150 Kcd     | 11,5 Kcd     |
| MIN lux/25m   | 6 lux/25m   | 32 lux/25m  | 2,72 lux/25m |
| MAX lux/25m   | 144 lux/25m | 240 lux/25m | 18,4 lux/25m |

**6. MEASURE GUIDELINE**



Measurement methods and recommendations following below regulations: ISO 10604. Road Vehicles – Measurements equipment for orientation of head lamp luminous beams.

**a. Getting Started**

Before you start the measurement procedure, you must verify that:



- The headlights are clean and dry;
- The wheels of the vehicle are in a straight position and to remove anything that can affect the correct trim of the vehicle (e.g. mud, snow, ice, etc);
- The vehicle has no distortions to the chassis;

- The tire pressure is correct;
- The headlight regulator inside the cockpit, where present, both in position and "0";
- The vehicle is on a flat surface.
- The vehicle manufacturer's provisions (e.g. full tank, etc. see ISO 10604)

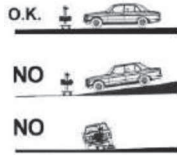

If area overall slope is higher than 0.1%, it is required to rework the working area to obtain a flat reference surface. Vehicle area can be reworked with a proper adjustable platform and headlight tester area can be completed with precision rail installation.



Vehicles equipped air suspension, engine must be on for five minutes before starting the test. Start headlights check only with engine on.

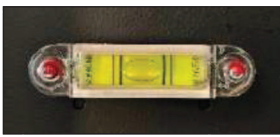

#### HEADLIGHT BEAM TESTER LEVELLING:

Position the headlight tester in the center of the related working area.

Check the position of the level inside the optical box, if it is not leveled correctly, you will need to level it.

- Loose the snap lever and position the center-forward to level
- Once the correct tilt is found, tighten the snap lever
- Double-check the correct leveling

## 7.2 Headlight tester positioning

Position the headlight tester in front of the car's headlight at a distance that can vary between 20-40 cm, measure the height from the floor to the center of the optical box and adjust the optical box to the corresponding height using the graduated scale printed on the column.

Use the top of the slide skate as the scale index.



### 7.2.1 Allineamento con visore a specchio

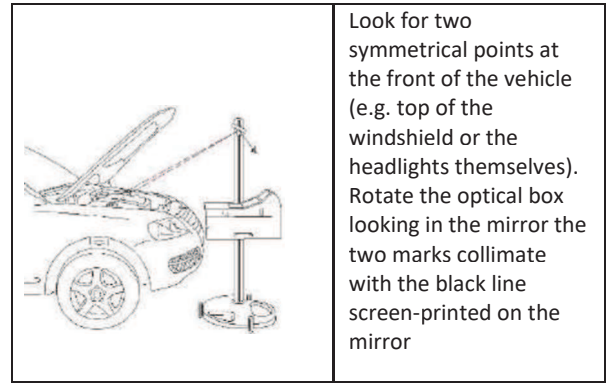
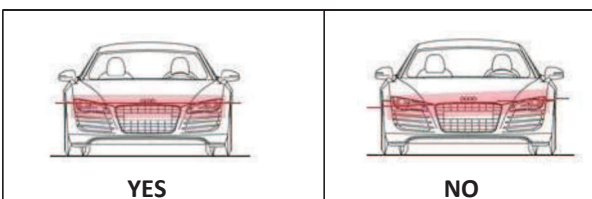

Look for two symmetrical points at the front of the vehicle (e.g. top of the windshield or the headlights themselves). Rotate the optical box looking in the mirror the two marks collimate with the black line screen-printed on the mirror

### 7.2.2 Laser visor alignment method

Headlight beam tester equipped with laser visor facilitates operator in aligning the unit in front of the car



Before you begin the alignment identify the working area to avoid staff exposure to the beam of the laser ray.

The laser device is class 3R according to la norm EN60825-1 Direct observation of the laser ray is not dangerous if eyelid reflex is preserved breaking the radiation of the cornea in less than 0.25 seconds, if eyes have no ocular applications (such as glasses). This case direct exposure is not recommended.

the alignment operations are complete, turn off the laser.

Look for two symmetrical points at the front of the car, (e.g.. windscreen or headlights themselves). Turn the optical box until the two reference points match with the line projected by the visor.

The laser visor is powered by 3 AA-type stylus batteries. How to replace: unscrew the 2 screws placed on the plastic lid, remove the discharged batteries, replace them with new ones paying attention to the polarity.

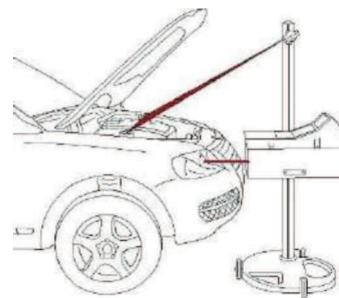

### 7.2.1 Headlight beam optical center alignment

#### BEAM TYPE INTRODUCTION

The actual versions of headlight beams on the market can be summarized in three main groups from the point of view of the end user:

- Parabola version
- Lenticular version
- LED matrix version



**Parabola version** consisting of a back slices panel and a bulb emitting the light projection.



**Lenticular version** consisting of a frontal lens emitting the light projection straight from the bulb through the lens.



**LED Matrix** assembly version consisting of specific single LED assembly in a detailed cell.

#### HOW TO CENTER THE BEAM

All Kraftwerk headlight testers are equipped with laser pointing system to ensure the correct aiming of the center of the beam/the bulb of the beam



**Parabola version:**  
Optical laser pointing system must be directed on the beam bulb



**Lenticular version:**  
Optical laser pointing system must be directed in the center of the lens.



MASTER LED shape

**LED assembly version:**  
Assembly beam has to be checked, starting from low beam position centering the

### 7.3 Measurement process



Test must be performed with the engine. If you are operating indoors, before starting the engine, start the exhaust gas extraction system to expel the exhaust gases outside the working environment in accordance with the current legal provisions.

In case of vehicles with air suspension turn on the engine five minutes before starting the test and proceed with engine on.

#### CONCEPTS OF HEADLIGHT BEAM ASSEMBLY

**INCLINATION = Vertical axel beam inclination**



**DEVIATION = horizontal axel beam deviation**

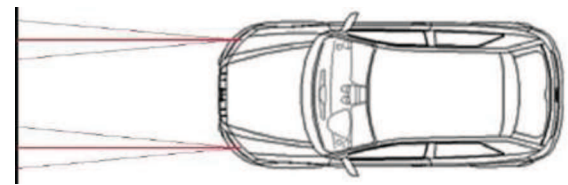

#### 7.3.1 Ec headlight beam

##### ADJUSTMENT

Read at the top of the headlight case of the vehicle and set the nominal inclination indicated by the manufacturer, e.g. 1.2%, rotate the wheel at the back of the optical chamber accordingly.

If there is no indication from the manufacturer, follow local current law.



**DANGER!**

Remember that the adjustment of the headlights still complies with the current law, which stipulates that **for the low beam** positioned at a working height **max 80 cm related vertical inclination must be 1%**

Low beam vertical inclination for a working height higher than 80 cm, reference vertical inclination must be at least 1.5%



**LOW BEAM CHECK**

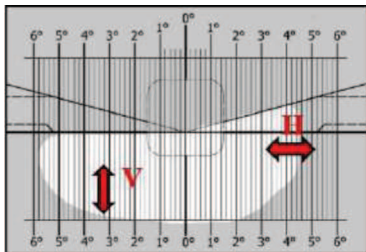

Image above is displaying a correct adjusted low beam.  
If light projection should be displaced above or below and left or right towards the HV main reference line, adjustment must be done till reconducting the image as above display

**HIGH BEAM CHECK**

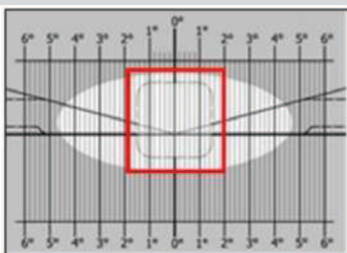

Image above is displaying a correct adjusted high beam.  
If light projection should be displaced above or below and left or right towards the HV main reference line, adjustment must be done till reconducting the image as above display

**FOG BEAM CHECK**

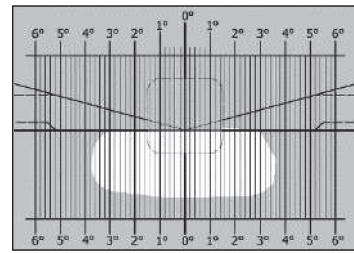
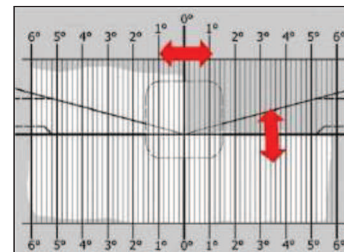

Image above is displaying a correct adjusted fog beam.  
If light projection should be displaced above or below and left or right towards the HV main reference line, adjustment must be done till reconducting the image as above display.

NB: on conventional basis reference vertical value for fog beam has to be considered – 2%

**INTELLIGENT BEAM – ADDED SEGMENT**

**DLA – DYNAMIC LIGHT ASSISTANCE**



Intelligent beam can also include added beam projection to low beam and high beam ones.  
DLA is a function to be activated through specific scan tool through EOBD.  
Usually all car manufacturer/EOM clearly determines values to be respected in such a projection position: check is linked to the position in the horizontal/vertical deviation.

## MATRIX SEGMENT

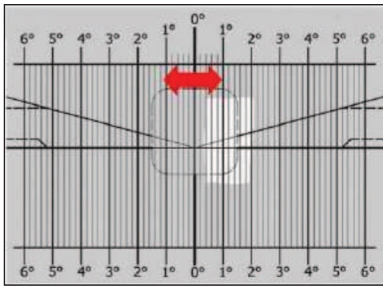

Intelligent beam can also include added beam projection to low beam and high beam ones. MATRIX SEGMENT is a function to be activated through specific scan tool through EOBD. Usually all car manufacturer/EOM clearly determines values to be respected in such a projection position: check is linked to the position in the horizontal deviation

## 7. UNDERSTANDING OF MEASURED VALUES.

The following Sections explain the most important measurement quantities required for headlamp adjustment.

### Pitch angle

The definition of the pitch angle is illustrated in the following.

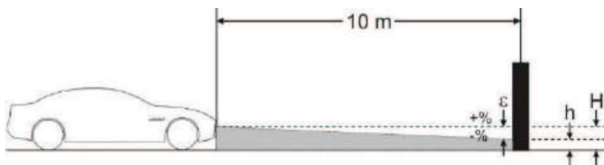

Fig. 10.1 Pitch angle

- "H": Height of centre of headlamp measured from the ground
- "h": Height of image projected by headlamp at a distance of 10 m, measured from the ground

- "ε": Pitch angle, calculated with the following formula:

$$\varepsilon = [(H-h) / 1000] \times 100$$

## 8.1 Ece European Standards

### 8.1.1 Low beam pattern

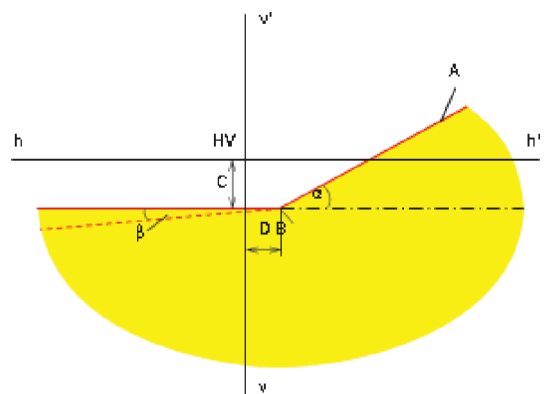

"A": bright-dim border, made up of two sections:

Horizontal section, rising straight line, also referred to as "shoulder". The bright-dim border must be within the tolerance range stipulated in the guideline.

"B": break point with asymmetrical light; center point with symmetrical light.

"C": deviation of the break point in vertical direction (also known as pitch angle). The value is always shown as an absolute value. Possible units:  
%, cm / 10 m, degrees

"D": deviation of the break point in horizontal direction. The value is always shown as an absolute value. Possible units:  
%, cm / 10 m, degrees

"α": angle between the "shoulder" and the horizontal section of the bright-dim border (also referred to as yaw angle with asymmetrical low beam).

- "β": angle between the left portion of the bright-dim border and the horizontal (also referred to as roll angle, usually 0°).

### 8.1.2 high beam pattern

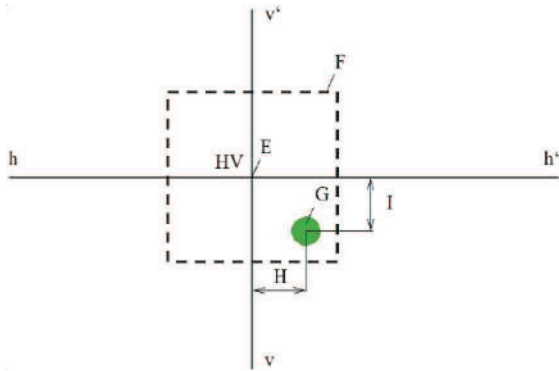

"E": zero point of beam setter (centre of headlamp). This point is the basis for the measured values. Deviations are measured from this point.

"F": tolerance range. The high beam hot spot should be within this range.

"G": hot-spot.

"H": horizontal distance of hot spot from centre point.  
Possible units:  
%, cm / 10 m, degrees

"I": vertical distance of hot spot from center point. Possible units:  
%, cm / 10 m, degrees

### 8.1.3 Fog beam pattern

The fog lamp is measured in a similar manner to the low beam, the difference being that the bright-dim does not have a break point but takes the form of a continuous horizontal line.

### 8.1.4 Intelligent beam

the introduction of intelligent headlamp systems, the accuracy of the headlamp configuration plays an increasingly important role. To be able to accurately set these headlamps, the vehicle manufacturers have provided a special

configuration screen for these headlamps. This must be selected with a diagnostics device

#### 8.1.4.1 Headlamps with Dynamic light Assistance

|   |                                      |
|---|--------------------------------------|
|   |                                      |
| <p>Left DLA headlamp projection</p>   | <p>Right DLA headlamp projection</p> |
| <p>"A": deviation of the bright-dim border in horizontal direction from the median. The value is always shown as an absolute value. Possible units:<br/>%, cm / 10 m, degrees</p> <p>"B": deviation of the bright-dim border in vertical direction from the median. The value is always shown as an absolute value. Possible units:<br/>%, cm / 10 m, degrees</p> |                                      |

#### 8.1.4.2 Matrix function headlamp

|   |   |
|---|---|
|   |   |
| <p>Left Matrix headlamp projection</p>  | <p>Right Matrix headlamp projection</p> |
| <p>"C": deviation of the bright-dim border in horizontal direction from the median. The value is always shown as an absolute value in angle minutes</p> |   |

### 8.1.4.3 Ford High Beam glare-free LED headlights (ILS).

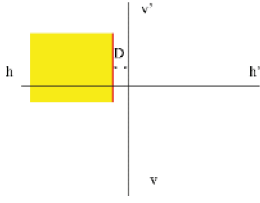
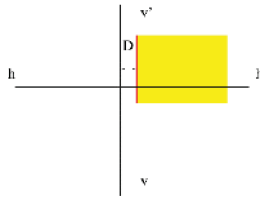
|  |   |
|--|---|
|   |  |
| Left ILS headlamp projection   | Right ILS headlamp projection   |
| <p>"D": Deviation of the cut-off line in horizontal direction from the median. The value is always shown as an absolute value; the following units are possible:<br/>%, cm / 10 m, degrees</p> |   |

## 8. PROBLEMS AND ANOMALIES

### Fault table

|  |  |  |  |
|--|--|--|--|
|  |  |  |  |
|  |  |  |  |
|  |  |  |  |
|  |  |  |  |
|  |  |  |  |
|  |  |  |  |



If the proposed intervention did not resolve the malfunction, operations must be stopped and Assistance Service must be called.



Never open optical box if not authorized.

In case of mishandling/opening/intervention in the inner part of the optical box warranty terms and conditions expire immediately and manufacturer declines any responsibility for product use.

## 9. DISPOSAL

### INFORMATION TO USERS

The equipment is made up mostly of steel. Other parts: plastic, some details cardboard and paper, packaging and documents paint of the device, in epoxy powder anti-scratch. For the disposal of the device comply with the provisions of the local authorities



## 10. INTERVENTION REQUEST FORM - SPARE PARTS

If there are any anomalies or malfunctions, Kraftwerk must be contacted to have the malfunction report form.

This is a guide form in which the Customer will specify the type of anomaly encountered and once completed Kraftwerk replies with actions list to resolve the issue.

## 11. ANNEX LIST

Annex to the operating manual:

|                      |
|----------------------|
| Document description |
|                      |
|                      |
|                      |
|                      |
|                      |

## 12. WARRANTY

### TERMS AND CONDITIONS:

Kraftwerk guarantees the equipment for the duration of 12 months.

Warranty period starts from the date of purchase indicated on the sales invoice from Kraftwerk to Customer.

Terms& conditions detailed through Kraftwerk and Kraftwerk authorized Distributor.

The company Kraftwerk . denies any liability for any damage to persons or things, caused by misuse or imperfect use of the equipment.

The Judicial Forum of ZÜRICH (SWITZERLAND) is responsible for any possible dispute.

