

3702510001

D127B ST HDG SPR WASH M10

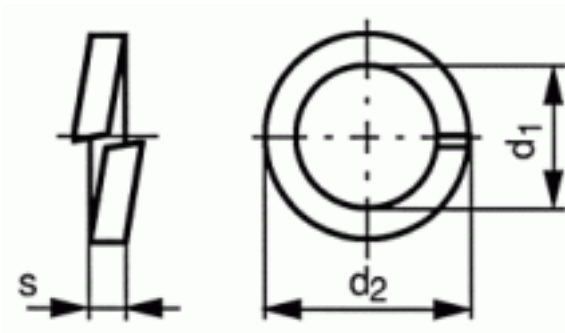

Brand	-
UBB Code	950357245097
UNSPSC Code	31161811
EAN Code	8715492764959
Surface treatment	Hot dip galvanized
Material technical	DIN267-26
Material	Spring steel



s	2,2
d2 (max.)	18,1
d1 (min.)	10,2
For nom. size	M10
Packaging (Piece )	200.0



Copyright Fabory Group