

16205120001

D6340 ST PHS WASH FOR CLAMP DEVICE M12

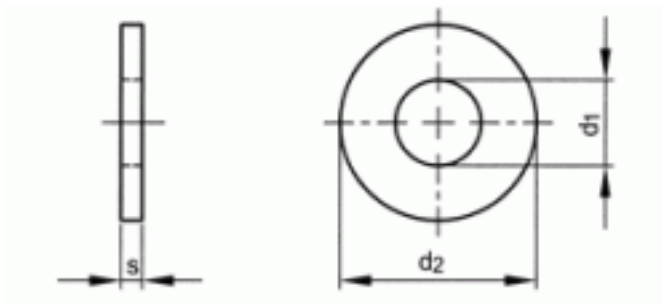

Brand	-
UBB Code	950356447645
UNSPSC Code	31161801
EAN Code	4020772082840
Material technical	350+80 HV30
Material	Steel



s	5
d2 (h14)	35
d1 (H14)	13
For nom. size	M12
Packaging (Piece)	50.0



Copyright Fabory Group