

14200100001

ST SPOT WELD NT M10

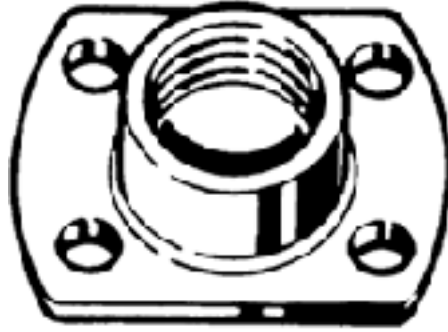

Brand	-
UBB Code	950355151479
UNSPSC Code	31161731
EAN Code	8715492582027
Material	Steel
Thread	Metric thread

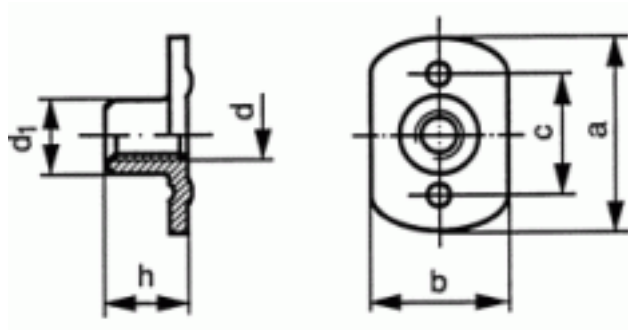

Number of welding spots	4
cEN	16
h	10,5
bEN	18
aEN	26
P	1,5
d	M10
Packaging (Piece )	500.0



Copyright Fabory Group