

**QUANTUM**

5420 – 5421  
5425 – 5430  
5435 – 5440

Led 1W      90 Lumen      3500° K  
Led 3,2 W    265 Lumen      3500° K  
58 Led 4,2 W   350 Lumen      3500° K  
Durata: 50000 h decadimento max 30%  
Life: with 30% max. decay 30%

IP 65   
 Classe II  
220-240 V 50-60Hz





EN 60 598-1:08 + A11:09





EN 62 471: 2008

sicurezza fotobiologica – gruppo di rischio: 0  
photobiological safety – risk group: 0  
sécurité photobiologique – groupe de risque: 0  
photobiologische Sicherheit – Risikogruppe: 0







cod. doc. 91297 rev. E  
cod. 089129700

 Utilizzare fili unipolari Sez. 1,5 mm<sup>2</sup> – Conservare le istruzioni.  Suggested wire section 1,5 mm<sup>2</sup> – Keep the instructions.  
 Utiliser fil de 1,5 mm<sup>2</sup> – Conserver les instructions  1,5 mm<sup>2</sup> Drat benutzen – Die Anleitungen bewahren.

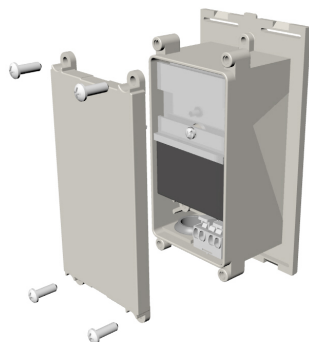
 **ATTENZIONE:** L'apparecchio è a tenuta stagna grado IP65.  
 **WARNING:** This lighting fitting is installed in wet location IP65 only if installed on a back-box Goccia cod. 5480, 5481 or 5482  
 **Attention:** L'appareil est étanche IP65 seulement lorsqu'il est installé sur le boîtier Goccia art. 5480, 5481 ou 5482  
 **Vorsicht:** Die Leuchte ist IP65 wasserdicht nur bei der Installation auf Einbaukasten Art. 5480, 5481 oder 5482

1





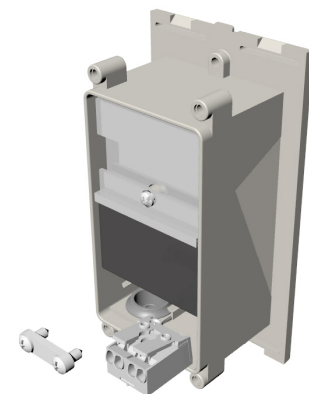

 Rimuovere il coperchio posteriore ed il ponticello blocca-cavo.  
 Remove the back door and the cable-block supplied  
 Ouvrez le couvercle à l'arrière et retirez le serre-fil.  
 Den Rückdeckel und die Kabelklemme entfernen.

2

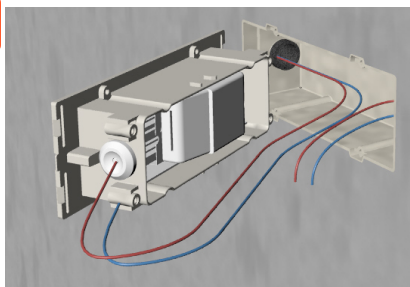





3

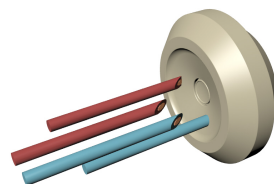

 Inserire i cavi di alimentazione attraverso il passacavo a membrana e collegarli alla morsetteria a levetta, dopo averli bloccati nel ponticello. Nel caso di alimentazione passante utilizzare il doppio ingresso per ogni polo  
 Insert the power conductors through the membrane cable entry and connect to the pushwire terminal block. In case of through wiring installation use the two cable entry / each terminal  
 Enfiler les conducteurs à travers le passe-fil avec membrane et câbler le borne a deux pôles.  
En cas de ligne traversante utiliser les deux entrée par pole  
 Die Speisekabel durch den Membran-kabeldurchgang ziehen und sie an den Hebelklemmenbrett verdrahten.  
Die Doppelkabeleinführung für jeden Pol im Fall der Durchgangsverkabelung verwenden

4



 Governare i cavi in modo da tenere la parte di membrana avvolgente il cavo all'esterno dell'apparecchio  
 Operate in order to keep the membrane around the cable towards out  
 Maintenir la membrane autour le câble vers l'extérieur  
 Den Kabel einhüllende Membranteil außen der Leuchte halten

5

5430 – 5435 – 5440

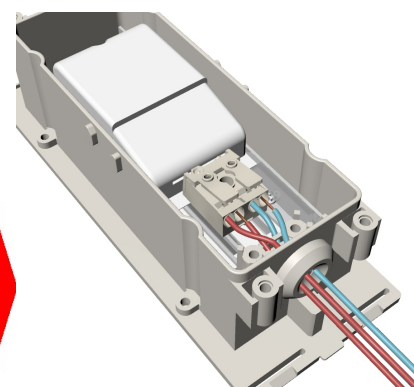

5420 – 5421 – 5425

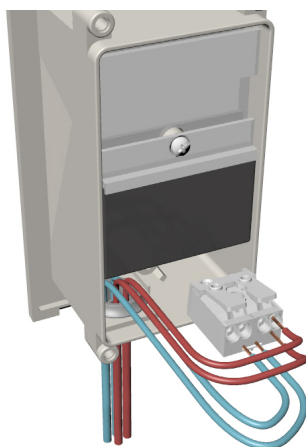



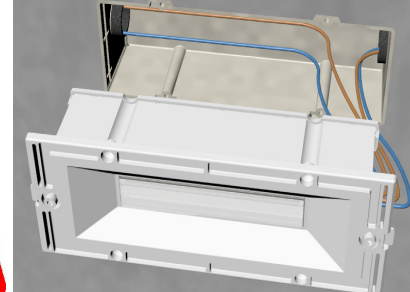

5

6

5430 – 5435 – 5440



 Chiudere il coperchio ed inserire il corpo lampada nella controcassa, dopo aver alloggiato i cavi in eccesso all'interno o nel corrugato  
 Close the back-door and insert the light body in the back-box. Pay attention to relocate the wiring inside  
 Reformer le couvercle, positionner la lampe ne la boîtier de coffrage. Attention a rappeler le surplus des câbles dans la boîtier  
 Den Rückdeckel schließen und das Leuchtgehäuse einführen, nachdem der überstehende Kabelteil im Einbaukasten gestellt worden ist



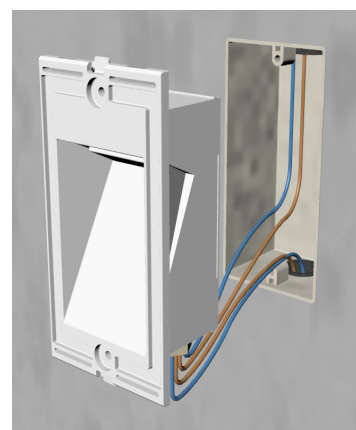

5420 – 5421 – 5425

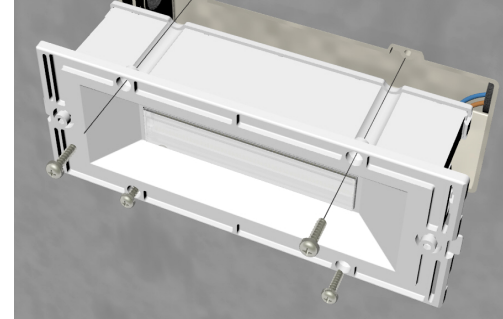

6





7

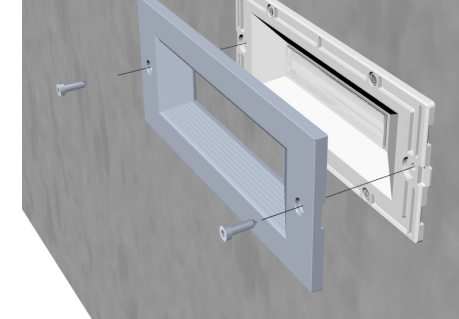

 Fissare maschera e corpo lampada sulla controcassa  
 Block the external mask and the light body to the back-box  
 Fixer la lampe et la cache dans le boîtier  
 Die Blende und das Leuchtgehäuse auf dem Einbaukasten befestigen

8



 La tenuta stagna è garantita se la controcassa è a filo muro. Se fosse rientrante utilizzare la guarnizione aggiuntiva qui fornita per compensare la mancanza di accoppiamento corpo lampada-controcassa  
 IP65 index is guaranteed only if the back-box is completely in line with the surface of the wall. If it's not so, you can use the additional gasket supplied, in order to compensate the level difference  
 Index de protection IP65 est garanti seulement si la boîtier de coffrage est parfaitement en ligne avec la surface de le mur. Si ce n'est pas, vous pouvez utiliser le joint d'étanché supplémentaire pour compenser la différence de niveau  
 Die IP65 Wasserdichtigkeit ist gewährleistet, wenn das Einbaukasten koplantar mit dem Mauer ist. Andernfalls die mitgelieferte Zusatzdichtung benutzen, um dem Höhenunterschied abzuwehfen

7